



ACO DRAIN

*Commercial trench drainage
Technical handbook & product catalog*



The ACO Group

Founded in 1946, the ACO Group manufactures products for the building and construction industry. Today, ACO employs over 4,000 people world-wide and has sales and manufacturing operations in more than 40 countries.

ACO is the pioneer and world leader of modular trench drain systems. ACO drainage systems are used in a variety of applications from domestic environments to airports. ACO products have been used at many prestigious locations, including Olympic stadiums, since 1972.



Arizona facility.

ACO USA

ACO USA was founded in 1978 and is America's foremost manufacturer of trench drainage products.

As market leader, ACO USA is constantly innovating to bring new products to the market.

ACO has a fully established R&D department responsible for continuous development, quality and testing to ensure ACO products continue to lead the market.



Ohio facility.

Trench drain pioneers

ACO Drain is the market leading modular trench drain system and is manufactured at the company's modern manufacturing facilities in Arizona and Ohio.

ACO Drain offers the most comprehensive range of trench drain solutions for every application. ACO Drain products are offered in a variety of widths, depths, and load ratings, with grates to suit. In conjunction with a comprehensive, quality product range, ACO supports its business with extensive stocking distributors, technical sales support and world class customer service.



Pioneers.

ACO. The future of drainage.

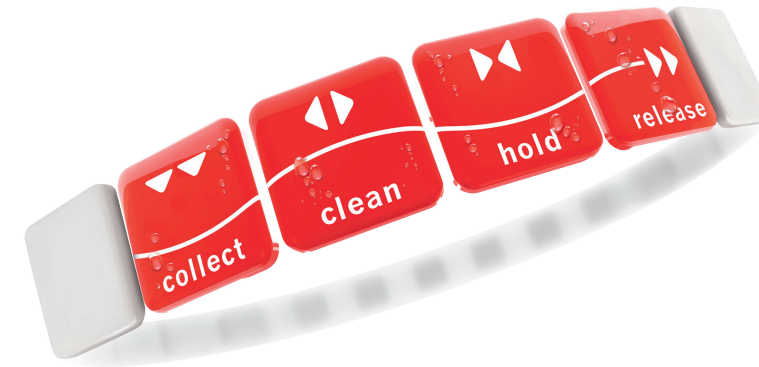

System chain

ACO is a global leader in surface water drainage. ACO manufactures products to collect, clean, hold and release water. This addresses all phases of the water cycle and supports Sustainable Drainage (SD, SUDS, WSUDS), Low Impact Development (LID) and LEED principles.



Collect

Trench drains
Catch basins



Clean

Oil/Water separators



Hold

Detention/Retention
devices



Release

Infiltration systems
Flow control

Service chain

To support this extensive product range, ACO provides full support from design conception to product after care.



Train

ACO believes in the benefits of education and is heavily involved in product training and continuing education.



Design

A complimentary design service is offered by qualified in-house engineers to help customers ensure the right product, layout and installation details.



Support

Technical Sales Support provide complimentary on-site training, assistance and advice during installation to ensure best possible results.



Care

Our customer service goes beyond getting the order. It starts with early design concepts and continues through the service life of the product.

Contents

Introduction - selecting the right product

What are trench drains?.....	6
Brief guide to trench drain selection	8

Product selector

Products - ACO Drain

KlassikDrain	14
K100	22
K200	34
K300	44
MiniKlassik K50	54
Brickslot 100/200	58
PowerDrain	62
S100K	66
S200K	76
S300K	86
Slab Solutions	96
SlabDrain 100/200/300	100
MembraneDrain	108
FlowDrain FG200	112

Technical support

Service A - Loading advice	128
Service B - Materials	136
Service C - Chemical resistance	139
Service D - User requirements	140
Service E - Trench hydraulics	142
Service F - Ponding	145
Service G - Grate intake hydraulics	146
Service H - Trench drain layouts	148

Installation

Generic section details	156
-------------------------------	-----

Glossary

.....	159
-------	-----



Introduction - selecting the right product

When selecting trench drains the following two main factors should be considered to ensure a long service life.

- 1 Application**
 - Installed location factors - loading, site & user requirements
- 2 Hydraulics**
 - Amount of liquid to collect and drain

Summarized information is provided on pages 8 - 9 with additional supporting information provided on pages 124 - 149.

What are trench drains?

A - Trench drain



A trench drain is a continuous line of surface drainage that removes liquid from impermeable/semi-permeable surfaces. It has a continuous inlet along the entire length ensuring maximum liquid capture. Trench drains allow simple one-way grading of surfaces to be drained.

Modular

Factory produced units offer consistent quality and can be created with advanced shape profiles and built in slope, providing additional benefits and savings.

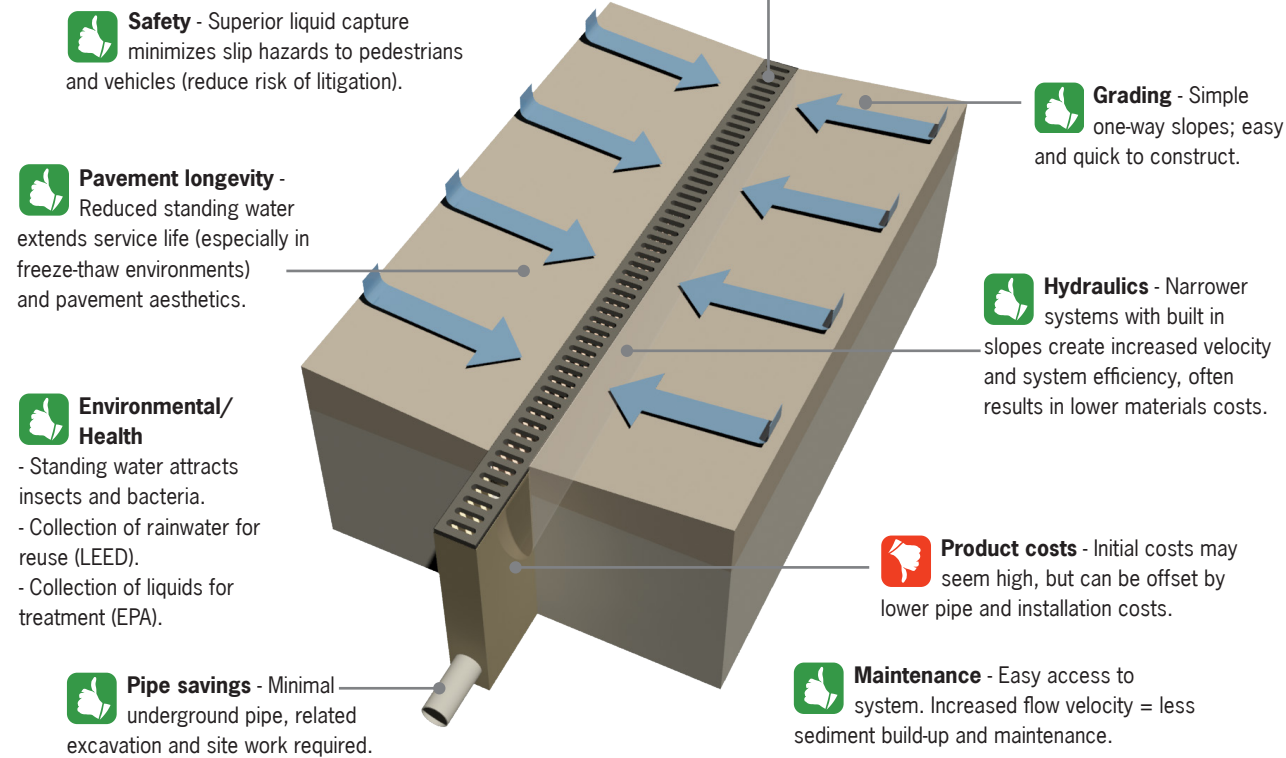

Cast-in-place

Boxed out trench created on-site during concrete pour. Offers many of the benefits and savings of modular trench drains with the following exceptions:

Deterioration - Concrete surface deteriorates, especially in freeze-thaw environments, resulting in lower performing hydraulics and hard to clean surfaces.

Wider grates - Typically wider grates are significantly more expensive - particularly in higher load class applications.

Site work - Excavation, formwork construction, creation of slope and 'U' or 'V' profile can be costly and time consuming. Tees/corners are difficult and time consuming to create.

Quality - Can vary greatly and be inconsistent depending upon the contractor. Difficult to achieve level grate and frame with good concrete support resulting in the common cause of many future problems.



Alternatives to a trench drain

B - Open swale

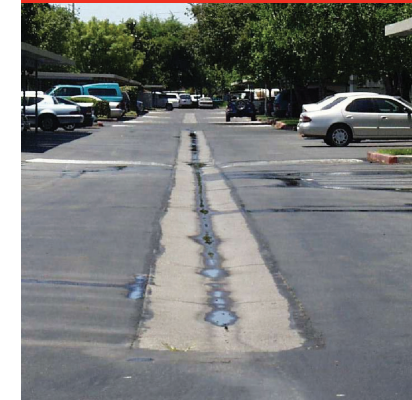

Formed ditch in pavement often leading to a catch basin.

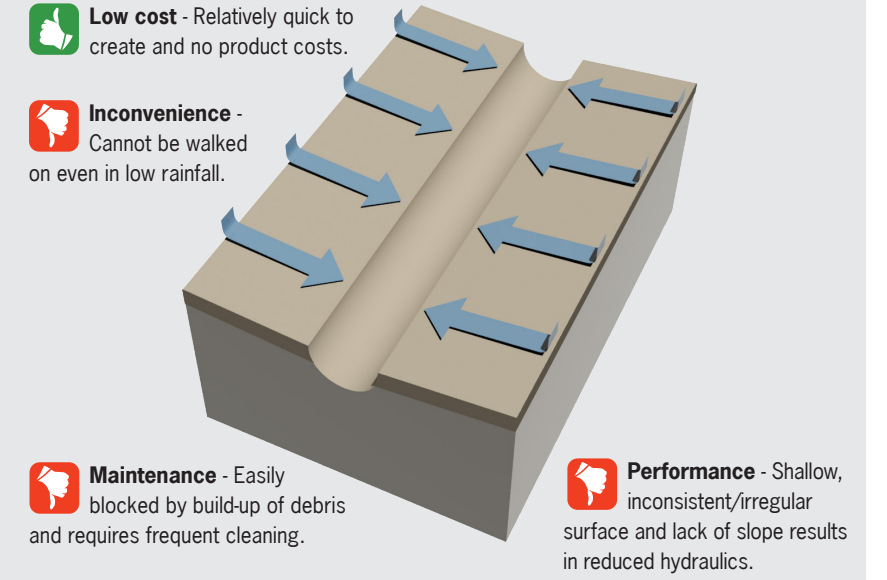

C - Catch basin



Series of catch basins located at strategic places in the pavement. Precise and exact grading is needed to drain effectively.

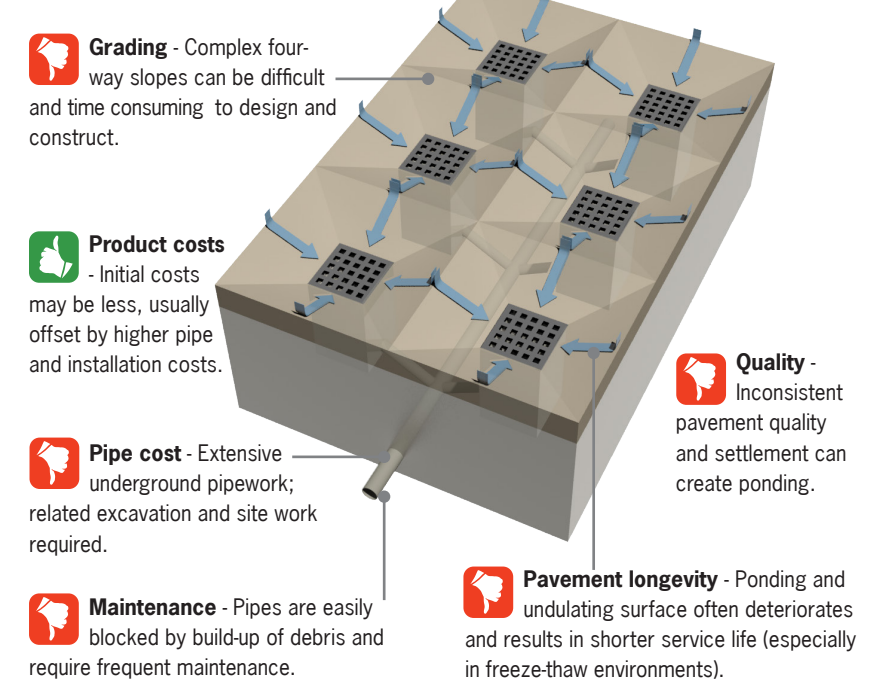

D - Do nothing

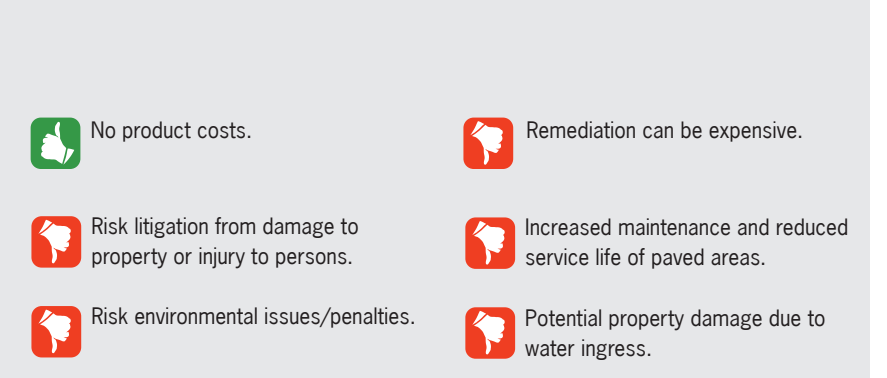

When selecting trench drains, the following factors should be considered to ensure a long service life.

1 Application

- Installed location factors; loading, site and user requirements

2 Hydraulics

- Amount of liquid to collect and drain

Summarized information is provided on these pages - additional supporting information is provided on pages 124-149.



1 Application



See page 126

A number of issues relating to where the drain is used are critical to address. Incorrect product choice could lead to product failure, remediation costs, possible litigation or 'over-engineered' solutions.



1a) Loading



See page 128

Loading refers to any kind of traffic or load being applied to the trench and grate. There are several US Load Standards relating to larger catch basin grates. ACO uses the EN 1433 standard which is specifically written for trench drains of different widths.

Loading is categorized into several load classes (light, medium and heavy). Choosing the correct solution is determined by:

- Type of traffic - Pedestrians, cars, trucks, forklift, aircraft, etc.
- Wheel loads - Include vehicle, weight of load being carried and type of tire (solid or pneumatic).
- 'Unusual' traffic - E.g. dumpsters/snow plows being dragged across trench etc.
- Frequency - Occasional versus frequent use may also affect product choice.

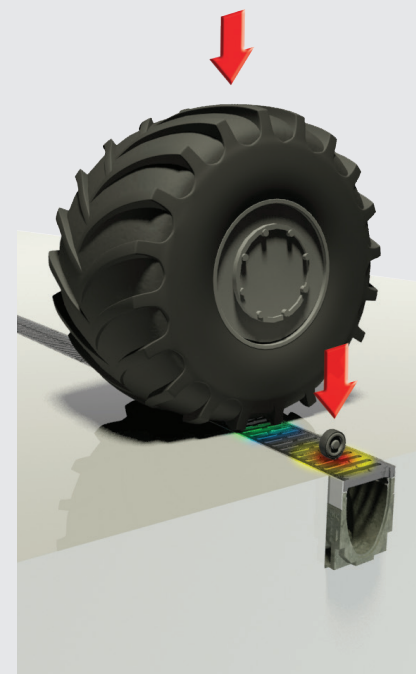

1b) Site requirements



See page 136

Specifics of the installed environment may drive, or limit, the choice of trench drain and grate.

- Installation restrictions such as limited down times may require trench drains that are quick to install.
- Limited construction depth may demand a shallow trench drain system.
- Chemicals, or other corrosive elements may influence channel and grate material choices. See page 139.
- Non-metallic trench drains may be required for factors other than chemical resistance - non-magnetic explosive environments (sparking) may be required in certain industrial applications.



- Environmental needs such as Sustainable Drainage, Low Impact Development (LID) or LEED qualification may be a determining factor in certain applications.
- Sloped trench drains may be required to eliminate standing water, which can provide a breeding ground for mosquitoes and potential health concerns - Malaria, SARS, West Nile virus, Zika, etc.

1c) User requirements



See page 140

User requirements typically affect the grate, as that is the exposed part once trench drain is installed.

Requirements are project specific and once loading requirements are met, grate choice typically relates to aesthetics, legal or safety concerns.

- Aesthetics - Intake shape (slots, holes or other shapes) and material (iron, stainless, plastic) can be chosen to complement surrounding landscape.
- Legal requirements typically relate to ADA compliance, heel safety and bicycle safe needs.



- Safety requirements typically refer to grate lockings and special surfaces (slip resistance). ACO recommends all grates are locked in place (especially in high load areas). Some applications may require multiple locks per grate or security lockings. On occasion, monolithic trench drains may be required for maximum grate security - See ACO Infrastructure product line.



2 Hydraulics



See page 142

The amount of liquid a trench drain needs to collect and drain in a given time period determines size.

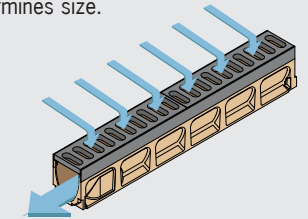

- Area available for flow (channel width AND depth) - Right combination avoids unnecessary costs and/or flooding.

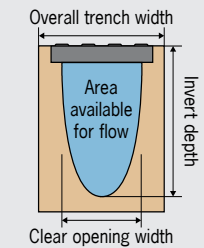

- Slope increases velocity providing a more efficient trench. Slope is added in 3 ways:
 - Sloping invert channels
 - Constant depth channels & ground slope
 - Combination of both

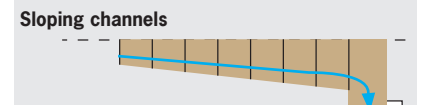
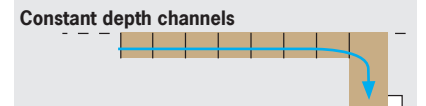

- Outlet size AND position
 - Avoid restricting flow with small pipe.
 - Central outlets may enable fewer outlets.
- Grate intake - Open area (calculated by size and quantity of openings) and slot design affect how much water gets into trench, and rate of bypass (water flowing straight over grate).



Product selector

Selection Criteria

1a) Loading notes

The amount of loading (weight) - pounds per square inch, a trench drain needs to withstand. All ACO products are independently certified to EN 1433, and relevant US load standards - full details and a comparison to common US load standards are provided on page 128-133.



Required load rating
Pg128

* EN 1433 suggests monolithic systems for Load class D due to dynamic loading of fast moving vehicles. See ACO Infrastructure HighwayDrain for product solutions.

** H100 is rated up to Load Class C even if grates of higher load class are used; H100K, H200K & H300K up to Load Class E (depending upon rating of grate chosen); H100SK, H200SK and H300SK up to Load Class F (depending upon rating of grate chosen).

*** MembraneDrain is recommended to a maximum of Load Class C even if grates of higher load class are used.

1b) Site requirements notes

Project environment may drive, or limit, the choice of trench drain and grate material.

For chemical and application requirements not met by standard products, ACO's Aquaduct line offers a range of different fiberglass resins and can be customized to suit. Stainless steel channels are also available. Contact (800) 543-4764 or info@acousa.com for details.



Chemical resistance
Pg139



Non-metallic option
Pg137



EPA, LEED, LID,
Sustainable Drainage
Pg138

1c) User requirements notes

Typically project-led criteria based on design preference or legislation compliance.



ADA compliant
Page 140



Heel resistant/Heel safe
Page 140



Bicycle Safe
Page 140



Grate lockings
Page 140



Aesthetic grates
Page 140



Anti-slip grates
Page 140

2 Hydraulics notes

Width, depth and slope of trench drain determines amount of liquid a trench can collect and drain in a given time period - if unsure, ACO can use software to determine the right size for specific projects. See page 142-147.



Hydraulic capacity
Pg142



Constant depth/sloped fall
Pg144

	KLASSIKDRAIN						POWERDRAIN			SLAB SOLUTIONS		
	K100	K200	K300	MiniKlassik	Brickslot100	Brickslot200	S100K	S200K	S300K	SlabDrain**	Membrane***	FG200
PAGE	22	34	44	54	58	58	66	76	86	100	108	112
LOADING EN 1433	ABCDE	ABCDE	ABCDE	ABC	ABC	ABC	ABCDEF	ABCDEF	ABCDEF	ABCDEF	ABC	ABCDE
A	✓	✓	✓	✓	✓	✓	✓	✓	✓	✓	✓	✓
B	✓	✓	✓	✓	✓	✓	✓	✓	✓	✓	✓	✓
C	✓	✓	✓	✓	✓	✓	✓	✓	✓	✓	✓	✓
D*	✓	✓	✓	✗	✗	✗	✓	✓	✓	✓ HK/HSK	✗	✓
E	✓	✓	✓	✗	✗	✗	✓	✓	✓	✓ HK/HSK	✗	✓
F	✗	✗	✗	✗	✗	✗	✓	✓	✓	✓ HSK	✗	✗
200,000 lb	✗	✗	✗	✗	✗	✗	✓	✓	F grate only	F grate only	✗	E grate only
HS20	! C & E grate only	! C & E grate only	! C & E grate only	! C grate only	✓	✓	✓	✓	✓	! C, E & F grate only	! C grate only	✓
HS25	! C & E grate only	! E grate only	! E grate only	! C grate only	✗	✗	✓	✓	✓	! E & F grate only	! C grate only	! E grate only
SITE REQUIREMENTS												
Channel material	Polymer concrete	Polymer concrete	Polymer concrete	Polymer concrete	Polymer concrete	Polymer concrete	Polymer concrete	Polymer concrete	Polymer concrete	Polymer concrete	Polymer concrete	Fiberglass
Edge rail	Galvanized or stainless steel	Galvanized or stainless steel	Galvanized or stainless steel	Galvanized or stainless steel	Galvanized or stainless steel	Galvanized or stainless steel	Ductile iron	Ductile iron	Ductile iron	Polymer concrete/steel/iron	Galvanized or stainless steel	Galvanized, coated or stainless steel
Grates												
Ductile iron	✓	✓	✓	✓	✗	✗	✓	✓	✓	✓	✓	✓
Galvanized steel	✓	✓	✓	✓	✓	✓	✗	✗	✗	✓	✓	✓
Stainless steel	✓	✓	✓	✓	✓	✓	✗	✗	✗	✓	✓	✓
Non-metallic	✓	✗	✗	✓	✗	✗	✗	✗	✗	✓ 100mm only	✓	✗
USER REQUIREMENTS												
Lockings	QuickLok™/DrainLok™	QuickLok™/DrainLok™	QuickLok™/DrainLok™	DrainLok™	NA	NA	PowerLok™/Bolted	PowerLok™/Bolted	PowerLok™/Bolted	Various	QuickLok™/DrainLok™	Bolted
Aesthetic options							✗	✗	✗			✗
Safety					Dependent on paver	Dependent on paver						
HYDRAULICS												
Channel width	4" 100mm	8" 200mm	12" 300mm	2" 50mm	4" 100mm	8" 200mm	4" 100mm	8" 200mm	12" 300mm	4" / 8" / 12" 100 / 200 / 300mm	4" 100mm	8" 200mm
Slope												
PAGE	22	34	44	54	58	58	66	76	86	100	108	112



Products - ACO Drain

ACO Drain consists of a wide selection of products to meet most project loading, design, hydraulic and budget requirements.

KlassikDrain	<i>General purpose trench drains.....</i>	<i>14</i>
	<i>K100.....</i>	<i>22</i>
	<i>K200.....</i>	<i>34</i>
	<i>K300.....</i>	<i>44</i>
	<i>MiniKlassik K50.....</i>	<i>54</i>
	<i>Brickslot 100/200.....</i>	<i>58</i>
PowerDrain	<i>Heavy duty trench drains.....</i>	<i>62</i>
	<i>S100K.....</i>	<i>66</i>
	<i>S200K.....</i>	<i>76</i>
	<i>S300K.....</i>	<i>86</i>
Slab Solutions	<i>Concrete slab trench drains.....</i>	<i>96</i>
	<i>SlabDrain 100/200/300.....</i>	<i>100</i>
	<i>MembraneDrain.....</i>	<i>108</i>
	<i>FlowDrain FG200.....</i>	<i>112</i>



KlassikDrain
General purpose trench drain

K100/KS100	22
K200/KS200	34
K300/KS300	44
MiniKlassik K50/KS50..	54
Brickslot100/200	58



KlassikDrain features

Wide choice of grates - In various materials and styles (including ADA compliant) for applications from Load Class A to Load Class E. See next page for more details.



QuickLok™ & DrainLok™ - Patented, boltless locking systems provide quick fitting and removal of grates. Helps reduce installation/maintenance time and cost.

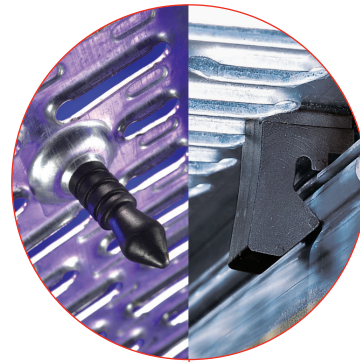

Channel identification - Channels feature numbering on sidewalls and base of channel (to allow easy identification after concrete encasement).

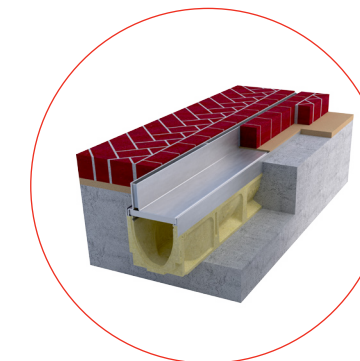

Brickslot 100 & 200 - A discreet drainage solution for use with brick or stone pavers. Available as standard, Heel Resistant and Twinslot versions. See page 58

Steel edge rail - Provides additional strength and protects channel body from damage. Stainless steel edge rail also available.

Direction arrows - Cast on side of channel indicate flow direction and ensure channels are installed correctly.

Profiled side walls - Strengthening pillars and frost keys provide channel body strength and mechanical keying to surrounding concrete.

Interconnecting end profiles - Allow easy and effective joining of channels. Appropriate sealant can be used to create a sealed joint.



Shipping gipple/groove - Side interlocking feature ensures safer stacking of channels on pallets for shipping and minimizes breakage.

K300 12" internal width

K200 8" internal width

K100 4" internal width

K50 2" internal width

Polymer concrete - A durable, yet lightweight material made from polyester a resin binder reinforced by mineral aggregates and fillers. It provides up to four times the compressive strength of cement concrete. See page 136 for material properties.

System numbering - Each end of the channel indicates the number of the channel that will connect to it.

Knock-outs - Included on all channel units to allow vertical evacuation of the system along the run. See product pages for sizes for each system.



Anti-shunt lugs - Protrusions in grate fit into recesses on the edge rail to prevent longitudinal movement.

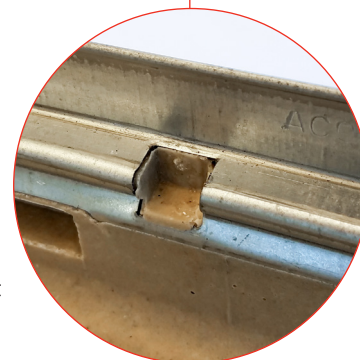

Sloped (0.5%) channel units - Meter long units provide 131'-3" continuous slope - equates to 1/17" fall per linear foot. Constant depth units can be used to extend run lengths.

MiniKlassik K50 - A 2" internal width, constant depth system for high profile, aesthetic applications where a barrier is required to separate wet and dry areas. See page 54.

Grate selection

A drainage grate's primary function is to let surface water enter the drainage system and allow efficient removal of excess water.

These grates have to remove the quantity of water specified and be strong enough to withstand traffic without collapsing.



Design criteria for grate

- Water intake capacity
- Loading
- Material - durability & aesthetics
- Slot style
- Legal requirements
 - ADA compliance
 - Slip resistance
 - Heel and bicycle safety
- Locking

In recent years, the visual importance of these drainage systems has become more prominent.

As the global leader, ACO has introduced many different sized patterns and materials, including discreet drainage concepts such as Brickslot.

The newest innovation is Freestyle - An easy and cost effective way to design your own iron grate.

ACO now offers a surface and grate **Visualizer**; an online tool that offers designers the chance to visualize each ACO Drain grate in a number of different pavements.

Choosing grates for trench drainage

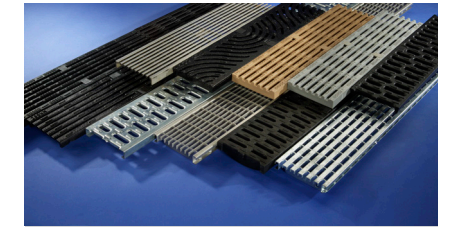

Standard grates

ACO Drain provides a wide selection of standard grates for all sizes and types of channels. These offer the most economic option and encompass popular styles and materials. Details can be found on:

- Page 30 - K100 grates
- Page 42 - K200 grates
- Page 52 - K300 grates
- Page 57 - K50 grates
- Page 74 - S100K grates
- Page 84 - S200K grates
- Page 94 - S300K grates
- Page 122 - FG200 grates



Freestyle grates

ACO offers a semi-custom option with the opportunity to design the top surface look of an iron grate to complement your project design. See page 20 for full details.



Exotic grate solutions

On rare occasions the grate design and/or material becomes a focal point. For these projects ACO can fully customize materials and/or finishes of grates to suit client requirements.

ACO DRAIN

Freestyle grates

Architectural features such as entrances, promenades, courtyards and landscaped areas, whether public or private, can all have their appearance significantly enhanced through the creative use of ACO Freestyle grates.

Flexible production tools with ACO's own foundries make it possible to create unique grate designs for projects with a custom surface design on a standard KlassikDrain DrainLok™ grate.

The two part tool consists of a standard lower part to provide the structural support of the grate and a customizable top part where the designers unique designs can be created.

A minimum order of 400 grates is required for this option.



Grate design

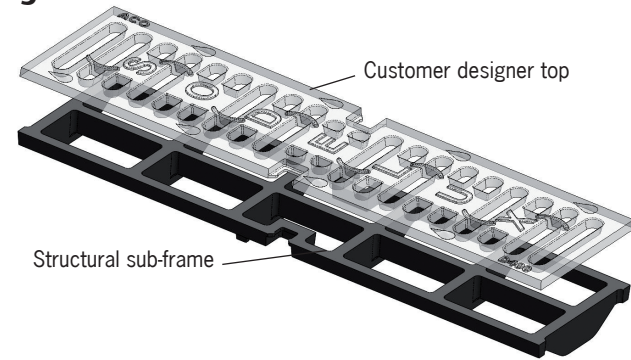

Features

- Load Class D to EN 1433
- ACO Freestyle grates are available for 4", 8" and 12" KlassikDrain systems
- Manufactured from ductile iron
- ACO DrainLok™ locking system

Examples

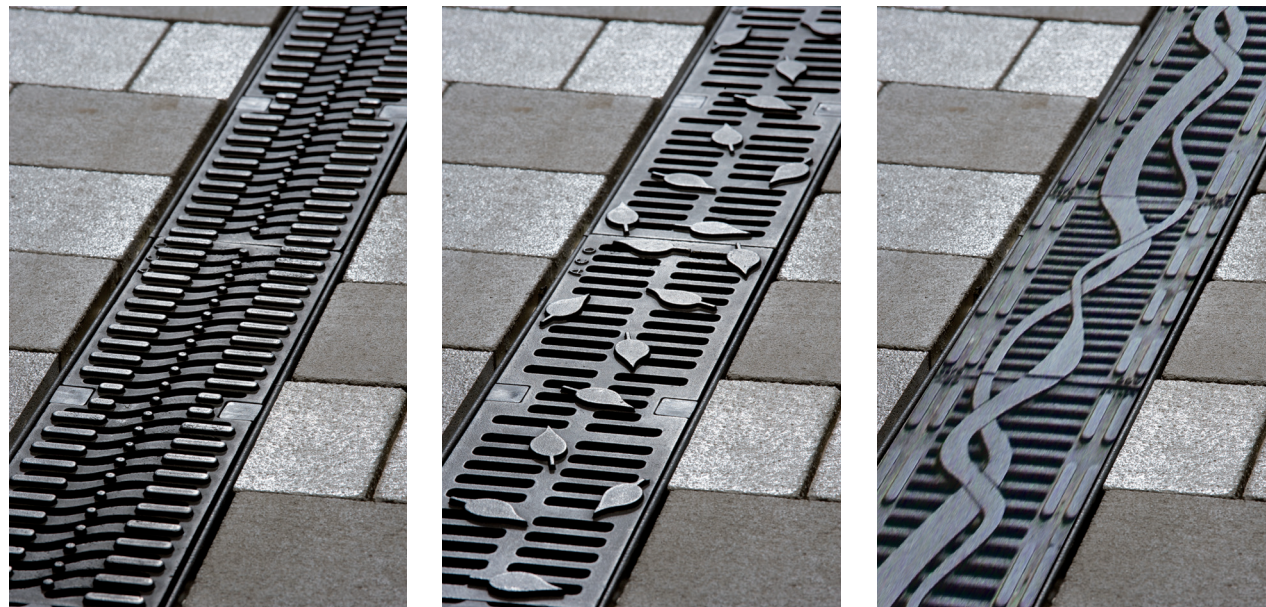



K100/KS100 - 4" wide general purpose system

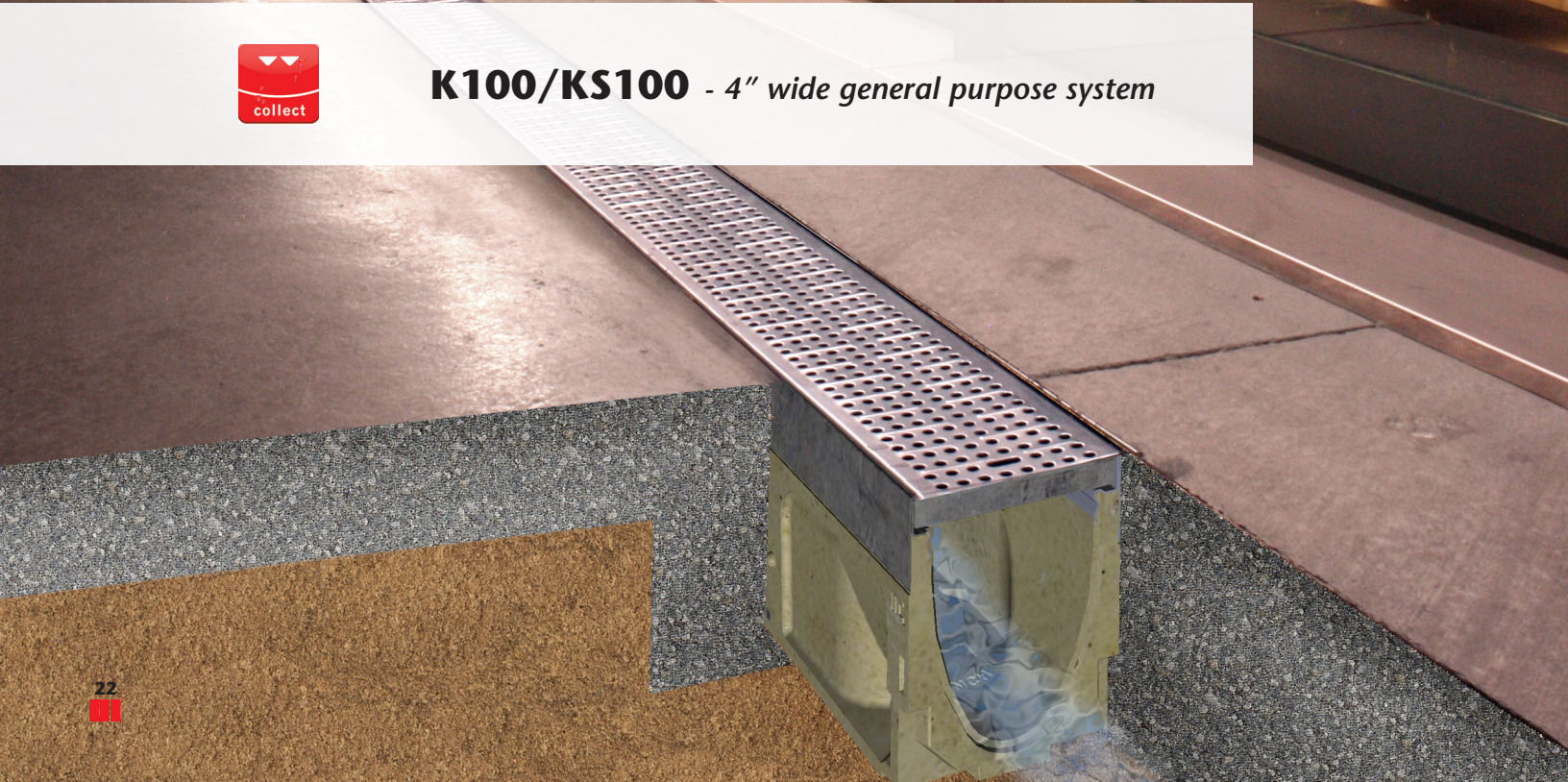

KlassikDrain K100/ KS100

Key Dimensions

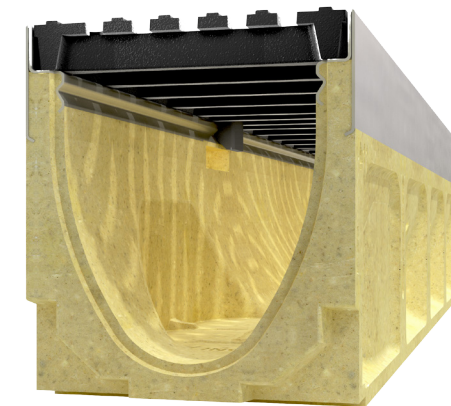
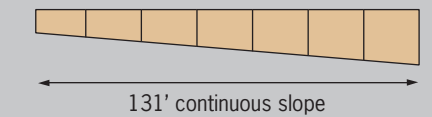
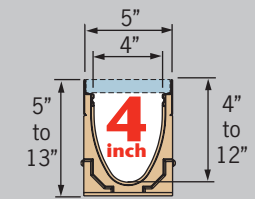







K100 is a 4" wide general purpose system with galvanized steel edge rail and the widest choice of grates in different materials and slot styles up to Load Class E (60 ton) featuring either patented DrainLok™ or QuickLok™ boltless locking systems.

KS100 is the same system, but the edge rail is grade 304 stainless steel. KS100 should be used where increased aesthetics are required or where increased corrosion resistance is required.

Typical applications

- Parking lots & garages
- Shopping malls
- Pedestrian areas
- Light industrial areas
- Commercial areas
- Internal applications

Selection criteria

-  Light to industrial duty loads
-  Product can be used towards LEED & EPA requirements
-  Resistant to many everyday chemicals. *Check page 139*
-  Multiple grate options to meet legal requirements
-  Multiple grate options to meet design requirements
-  General everyday hydraulic capacity
-  Constant depth and/or sloped depth channels



System layout

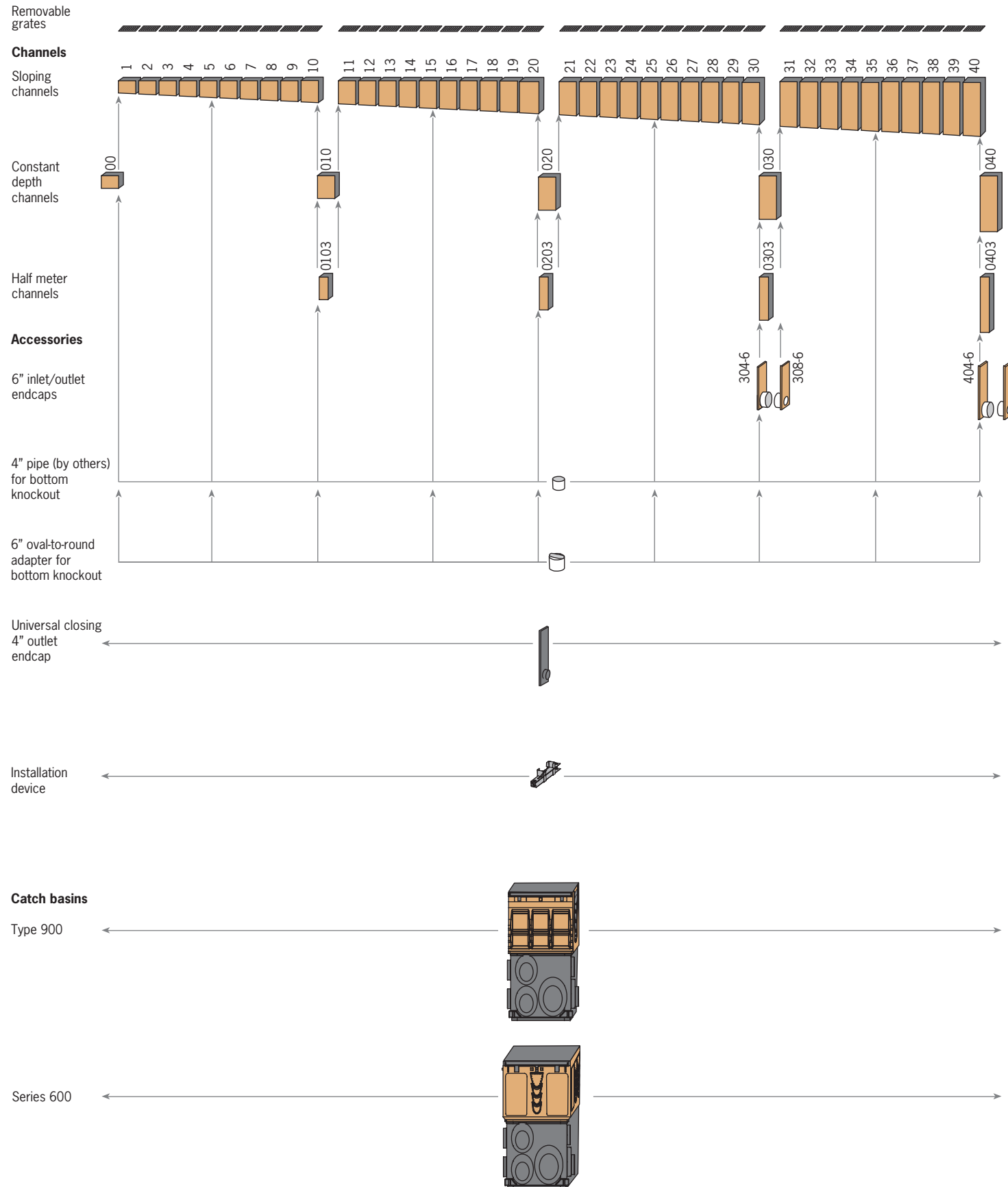

Meter channels - sloping & constant depth

0.5% sloped channels in meter lengths and 40 depths which connect to create 40 meter (131'-2") continuously sloping run. Available with either galvanized or stainless steel edge rail.

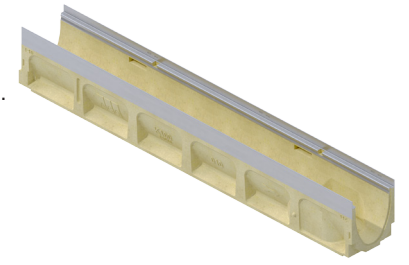

Constant depth channels available in 5 depths. Can be used to create non-sloped runs, or inserted in sloped runs to increase length.

Bottom knockouts on all constant depths and 5, 10, 15, 20, 25, 30, 35, 40 channels.

Half meter channels



Constant depth channels in 4 depths supplement meter channels. Side knockout and profiling enable side junction to be created. Bottom knockouts on all half meter channels. Available with either galvanized or stainless steel edge rail.

6 in. Sch. 40 inlet/outlet caps

6" Schedule 40 plain end polypropylene pipe; oval to round adapter cast into polymer concrete end cap and available in two heights. Solvent weld to coupler.
Note: These end caps cannot be cut to height, and fit only at positions shown in layout diagram.

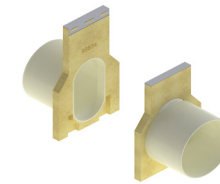

Closing/4 in. inlet/outlet cap

Fits all channels and manufactured from gray ABS to complement edge rail. Guides aid cutting to correct height. Wings clip cap onto end of channel. 4" bell end connection to Schedule 40 pipe. Seal using PVC-ABS cement.
Note: For depth 1-10 channels, ACO recommends removal of unused sections of bell end to ensure adequate pavement material coverage.



Installation device

Fits molded recesses on body of channel. Provides height and joint alignment - a sliding clamp locks the two channels together. Bolt to rebar on either side of channel to hold channels in place during concrete pour. Not reusable; it is 'lost' within concrete haunch.

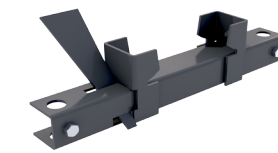

Type 901 In-line catch basin

Two part in-line catch basin with 4", 6" and 8" drill-outs for pipe connection. Supplied with plastic trash bucket. Options include an in-line or side foul air trap. Available with either galvanized or stainless steel edge rail.

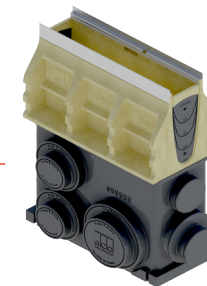

Any channel can be connected into the catch basin by removing the end wall to the correct height with a box cutter. Cut-out guides provided for connection to channels 00, 010, 020, 030 and 040. All cut-outs to receive male channel ends. One blanking end plate supplied with in-line catch basin.

Series 600 catch basin

Two part catch basin; bases have 4", 6" and 8" drill-outs for pipe connections. Supplied with plastic trash bucket. Optional riser available for increased depth. Contact ACO for non-polyethylene riser/bases. Available with either galvanized or stainless steel edge rail.

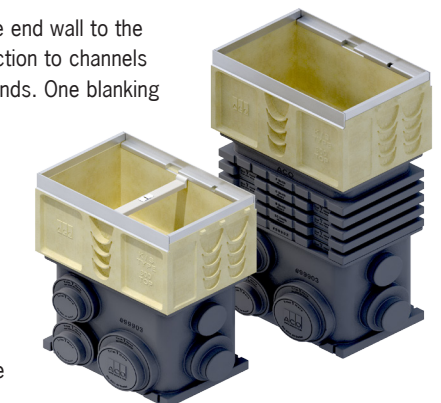

Any channel can be connected to catch basin by removing end/side wall to correct height. Drill-outs guide connection to channels 00, 010, 020, 030 and 040. All cut-outs to receive male channel ends.

Meter channels

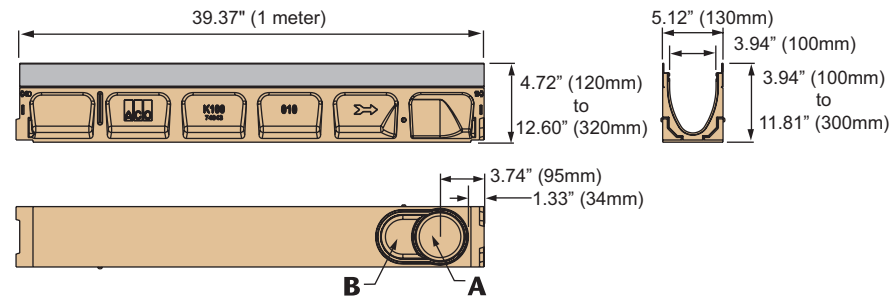

Half meter channels

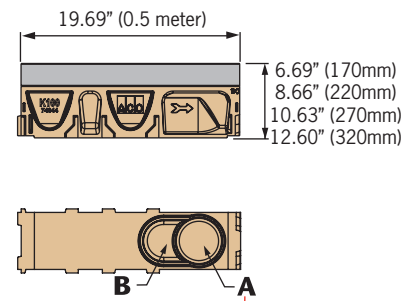

6 in. Sch. 40 inlet/outlet caps

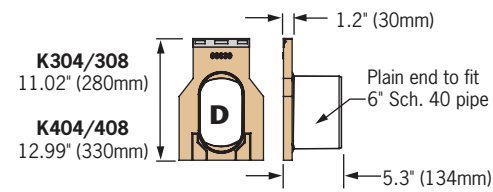

Closing/4 in. inlet/outlet cap

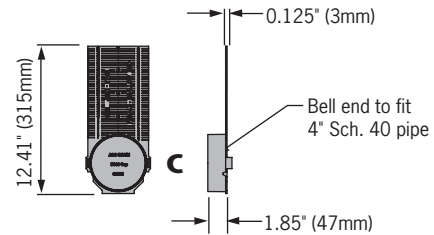

Installation device

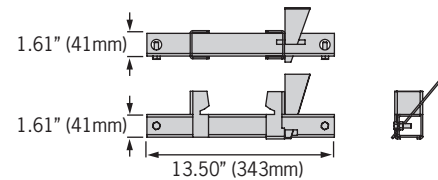

K1-901G/S In-line catch basin

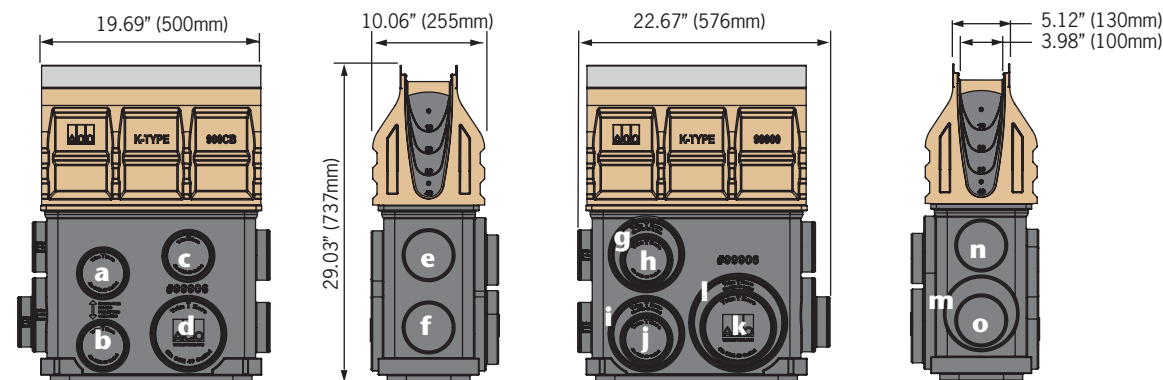

Outlet flow rates

Channels		Invert in.	GPM	CFS
A	K1-00 - 4" round	3.94"	108	0.24
A	K1-40 - 4" round	11.81"	187	0.42
B	K1-00 - 6" oval	3.94"	177	0.39
B	K1-40 - 6" oval	11.81"	306	0.68
C	K1-20 - 4" round	7.87"	132	0.29
C	K1-40 - 4" round	11.81"	171	0.38
D	K1-30 - 6" oval	9.84"	233	0.52
D	K1-40 - 6" oval	11.81"	264	0.59

Catch basins		K1-901G/S			K1-621G/S			K1-631G/S		
Outlet	Size (Sch 40)	Invert in.	GPM	CFS	Invert in.	GPM	CFS	Invert in.	GPM	CFS
a	4" round	20.68"	235	0.52	21.29"	239	0.53	33.29"	305	0.68
b	4" round	27.17"	273	0.61	27.79"	276	0.62	39.79"	335	0.75
c	4" round	18.99"	224	0.50	19.72"	229	0.51	31.72"	297	0.66
d	6" round	27.17"	602	1.34	27.79"	610	1.36	39.79"	743	1.66
e	4" round	19.30"	226	0.50	19.84"	230	0.51	31.84"	297	0.66
f	4" round	25.67"	265	0.59	26.34"	269	0.60	38.34"	328	0.73
g	6" round	19.99"	505	1.12	20.62"	514	1.15	32.62"	667	1.49
h	4" round	19.36"	227	0.51	20.07"	231	0.52	32.07"	299	0.67
i	6" round	27.30"	604	1.35	27.76"	609	1.36	39.76"	743	1.65
j	4" round	26.43"	269	0.60	27.19"	273	0.61	39.19"	332	0.74
k	6" round	26.43"	593	1.32	27.19"	602	1.34	39.19"	737	1.64
l	8" round	27.30"	1051	2.34	27.76"	1061	2.36	39.76"	1302	2.90
m	6" round	25.85"	586	1.30	26.28"	591	1.32	38.28"	728	1.62
n	4" round	18.56"	222	0.49	19.15"	225	0.50	31.15"	294	0.65
o	4" round	25.30"	263	0.59	25.86"	266	0.59	37.86"	326	0.73

Note: These are pipe flow rates at specified outlet, **NOT** channel flow rates. Catch basin flow rates without trash bucket - using trash bucket reduces flow.

K1-621G/S catch basin

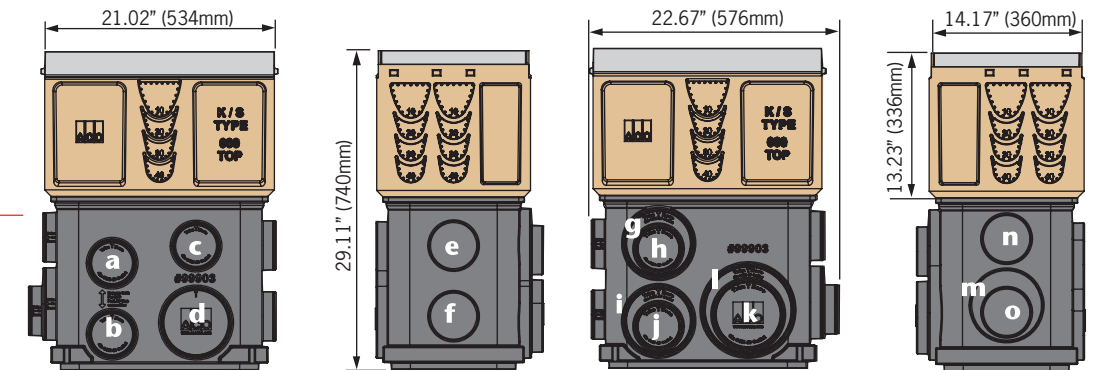

K1-631G/S catch basin

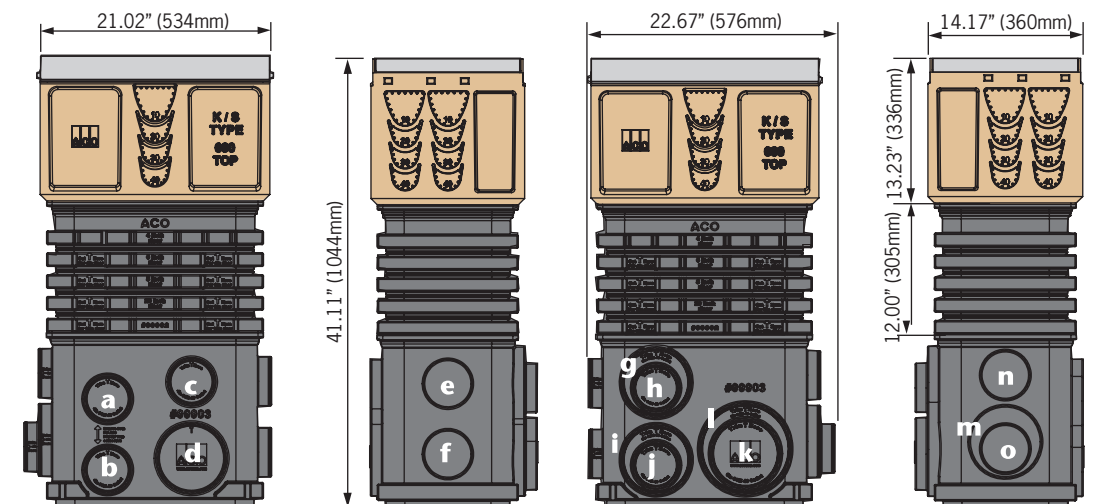

K100/KS100 Parts table

	Part No		Invert Depth				Overall Depth				Vol	Wgt
	K100	KS100	Inches		mm		Inches		mm		Gal	lbs
			female	male	female	male	female	male	female	male		
K1-00 Constant depth channel - 39.37" (1m) ³	74041	74441	3.94	3.94	100	100	4.72	4.72	120	120	1.96	28.1
K1-1 Sloped channel - 39.37" (1m)	74001	74401	3.94	4.13	100	105	4.72	4.92	120	125	1.99	28.1
K1-2 Sloped channel - 39.37" (1m)	74002	74402	4.13	4.33	105	110	4.92	5.12	125	130	2.04	28.9
K1-3 Sloped channel - 39.37" (1m)	74003	74403	4.33	4.53	110	115	5.12	5.31	130	135	2.13	29.7
K1-4 Sloped channel - 39.37" (1m)	74004	74404	4.53	4.72	115	120	5.31	5.51	135	140	2.23	30.5
K1-5 Sloped channel - 39.37" (1m) ³	74005	74405	4.72	4.92	120	125	5.51	5.71	140	145	2.33	31.3
K1-6 Sloped channel - 39.37" (1m)	74006	74406	4.92	5.12	125	130	5.71	5.91	145	150	2.43	32.1
K1-7 Sloped channel - 39.37" (1m)	74007	74407	5.12	5.31	130	135	5.91	6.10	150	155	2.54	32.9
K1-8 Sloped channel - 39.37" (1m)	74008	74408	5.31	5.51	135	140	6.10	6.30	155	160	2.65	33.7
K1-9 Sloped channel - 39.37" (1m)	74009	74409	5.51	5.71	140	145	6.30	6.50	160	165	2.75	34.5
K1-10 Sloped channel - 39.37" (1m) ³	74010	74410	5.71	5.91	145	150	6.50	6.69	165	170	2.86	35.3
K1-010 Constant depth channel - 39.37" (1m) ³	74043	74443	5.91	5.91	150	150	6.69	6.69	170	170	2.85	35.3
K1-0103 Constant depth channel - 19.69" (0.5m) ³	74044	74444	5.91	5.91	150	150	6.69	6.69	170	170	1.43	17.0
K1-11 Sloped channel - 39.37" (1m)	74011	74411	5.91	6.10	150	155	6.69	6.89	170	175	2.97	36.1
K1-12 Sloped channel - 39.37" (1m)	74012	74412	6.10	6.30	155	160	6.89	7.09	175	180	3.08	36.9
K1-13 Sloped channel - 39.37" (1m)	74013	74413	6.30	6.50	160	165	7.09	7.28	180	185	3.19	37.7
K1-14 Sloped channel - 39.37" (1m)	74014	74414	6.50	6.69	165	170	7.28	7.48	185	190	3.30	38.5
K1-15 Sloped channel - 39.37" (1m) ³	74015	74415	6.69	6.89	170	175	7.48	7.68	190	195	3.42	39.3
K1-16 Sloped channel - 39.37" (1m)	74016	74416	6.89	7.09	175	180	7.68	7.87	195	200	3.53	40.1
K1-17 Sloped channel - 39.37" (1m)	74017	74417	7.09	7.28	180	185	7.87	8.07	200	205	3.64	40.9
K1-18 Sloped channel - 39.37" (1m)	74018	74418	7.28	7.48	185	190	8.07	8.27	205	210	3.75	41.7
K1-19 Sloped channel - 39.37" (1m)	74019	74419	7.48	7.68	190	195	8.27	8.46	210	215	3.86	42.5
K1-20 Sloped channel - 39.37" (1m) ³	74020	74420	7.68	7.87	195	200	8.46	8.66	215	220	3.98	43.4
K1-020 Constant depth channel - 39.37" (1m) ³	74045	74445	7.87	7.87	200	200	8.66	8.66	220	220	3.97	43.4
K1-0203 Constant depth channel - 19.69" (0.5m) ³	74046	74446	7.87	7.87	200	200	8.66	8.66	220	220	1.98	20.5
K1-21 Sloped channel - 39.37" (1m)	74021	74421	7.87	8.07	200	205	8.66	8.86	220	225	4.09	44.2
K1-22 Sloped channel - 39.37" (1m)	74022	74422	8.07	8.27	205	210	8.86	9.06	225	230	4.20	45.0
K1-23 Sloped channel - 39.37" (1m)	74023	74423	8.27	8.46	210	215	9.06	9.25	230	235	4.32	45.8
K1-24 Sloped channel - 39.37" (1m)	74024	74424	8.46	8.66	215	220	9.25	9.45	235	240	4.42	46.6
K1-25 Sloped channel - 39.37" (1m) ³	74025	74425	8.66	8.86	220	225	9.45	9.65	240	245	4.54	47.4
K1-26 Sloped channel - 39.37" (1m)	74026	74426	8.86	9.06	225	230	9.65	9.84	245	250	4.66	48.2
K1-27 Sloped channel - 39.37" (1m)	74027	74427	9.06	9.25	230	235	9.84	10.04	250	255	4.78	49.0
K1-28 Sloped channel - 39.37" (1m)	74028	74428	9.25	9.45	235	240	10.04	10.24	255	260	4.89	49.8
K1-29 Sloped channel - 39.37" (1m)	74029	74429	9.45	9.65	240	245	10.24	10.43	260	265	5.00	50.6
K1-30 Sloped channel - 39.37" (1m) ³	74030	74430	9.65	9.84	245	250	10.43	10.63	265	270	5.11	51.4
K1-030 Constant depth channel - 39.37" (1m) ³	74047	74447	9.84	9.84	250	250	10.63	10.63	270	270	5.10	51.4
K1-0303 Constant depth channel - 19.69" (0.5m) ³	74048	74448	9.84	9.84	250	250	10.63	10.63	270	270	2.55	24.0
K1-31 Sloped channel - 39.37" (1m)	74031	74431	9.84	10.04	250	255	10.63	10.83	270	275	5.23	52.2
K1-32 Sloped channel - 39.37" (1m)	74032	74432	10.04	10.24	255	260	10.83	11.02	275	280	5.34	53.0
K1-33 Sloped channel - 39.37" (1m)	74033	74433	10.24	10.43	260	265	11.02	11.22	280	285	5.45	53.8
K1-34 Sloped channel - 39.37" (1m)	74034	74434	10.43	10.63	265	270	11.22	11.42	285	290	5.56	54.6
K1-35 Sloped channel - 39.37" (1m) ³	74035	74435	10.63	10.83	270	275	11.42	11.61	290	295	5.68	55.4
K1-36 Sloped channel - 39.37" (1m)	74036	74436	10.83	11.02	275	280	11.61	11.81	295	300	5.79	56.2
K1-37 Sloped channel - 39.37" (1m)	74037	74437	11.02	11.22	280	285	11.81	12.01	300	305	5.91	57.0
K1-38 Sloped channel - 39.37" (1m)	74038	74438	11.22	11.42	285	290	12.01	12.20	305	310	6.02	57.9
K1-39 Sloped channel - 39.37" (1m)	74039	74439	11.42	11.61	290	295	12.20	12.40	310	315	6.13	58.7
K1-40 Sloped channel - 39.37" (1m) ³	74040	74440	11.61	11.81	295	300	12.40	12.60	315	320	6.25	59.5
K1-040 Constant depth channel - 39.37" (1m) ³	74049	74449	11.81	11.81	300	300	12.60	12.60	320	320	6.24	59.5
K1-0403 Constant depth channel - 19.69" (0.5m) ³	74050	74450	11.81	11.81	300	300	12.60	12.60	320	320	3.12	27.5
K1-304-6 6" inlet cap	96839	96844	9.84	9.84	250	250	11.02	11.02	280	280	-	5.2
K1-308-6 6" outlet cap	96840	96845	9.84	9.84	250	250	11.02	11.02	280	280	-	5.0
K1-404-6 6" inlet cap	96834	96846	11.81	11.81	300	300	12.99	12.99	330	330	-	6.0
K1-408-6 6" outlet cap	96836	96847	11.81	11.81	300	300	12.99	12.99	330	330	-	5.8
Universal end/4" inlet outlet cap	96822	-	11.81	11.81	300	300	12.40	12.40	315	315	-	0.4
Debris strainer for 4" bottom knockout	93488	-	-	-	-	-	-	-	-	-	-	0.2
4" oval to 6" round outlet adapter	95140	-	-	-	-	-	-	-	-	-	-	1.1
Installation device	97477	-	-	-	-	-	-	-	-	-	-	2.8
Grate removal tool	01318	-	-	-	-	-	-	-	-	-	-	0.3
QuickLok™ locking bar	02899	-	-	-	-	-	-	-	-	-	-	0.1

- Notes:**
- K100 has a galvanized steel edge rail for general use. KS100 has a grade 304 stainless steel edge rail for use where increased aesthetics or corrosion resistance is required.
 - KlassikDrain is sold as channel only. Choose appropriate grate from pages 30-33.
 - Preformed 4" dia. & 6" oval drill-outs cast on underside of certain channels (00, 5, 10, 010, 0103, 15, 20, 020, 0203, 25, 30, 030, 0303, 35, 40, 040, 0403).
 - Closing/4" outlet closing cap can be cut down to suit all channels.
 - Catch basin details on page 29.
 - Debris strainer details for 4" dia. outlet on page 103.

Polymer concrete catch basins

Polymer concrete catch basins are used either as standalone area drains or most commonly as the outlet to a trench run. They provide the highest hydraulic output and allow easy access to the pipe system for maintenance.

The Type 901 provides an in-line catch basin (same width and visually indistinguishable from the trench run) and the Series 600 is 12" wide and provides a greater hydraulic output.

K1-Type 901
4 in. wide in-line catch basin

QuickLok™ locking bar

QuickLok™ locking bar

K1-Series 600
12 in. wide catch basin

QuickLok™ locking bar

Series 600 grates - choice of grates to match/complement channel with DrainLok™ or QuickLok™ boltless locking. *See page 52-53.*

Type 900 grates - choice of grates to match channel grates with DrainLok™ or QuickLok™ boltless locking. *See page 30-33.* QuickLok™ grates require a removable QuickLok™ locking bar for easy access to trash bucket and pipework.

Top section - polymer concrete with integrally cast-in galvanized or stainless steel frame. Guides aid connection of male channel ends at #10, 20, 30 and 40 depths. Other channels can be connected by removing wall to required height. Blanking end rail supplied with K1-901. *See page 155.*

Trash bucket - plastic trash bucket designed to collect debris washed from trench run. Supported in catch basin top to avoid creation of a vacuum and reduction in outflow. K1-631 uses deeper bucket with riser.

Riser - a plastic riser, supplied with K1-631, designed to provide additional catch basin depth and hydraulic output. Guides enable cutting to size at 2" (50mm) intervals - minimum 2" and maximum 12" height. Additional units can be used (a maximum of 2 is recommended to ensure snake access is maintained and for structural stability). Contact ACO for non-polyethylene riser.

Base - polyethylene bases with wide range of Schedule 40 4", 6" and 8" cut-outs for easy pipe connection. Cut outs on end and side allow connection of ACO foul air trap. Contact ACO for non-polyethylene bases.

Parts table - K100 Catch basins

	Part No.		Volume	Weight
	K100	KS100	Gallons*	lbs
K1-901 in-line catch basin - 19.69" (0.5m)	94608	94609	12.3	52.6
K1-621 catch basin - 19.69" (0.5m)	94617	94618	24.9	55.8
K1-631 catch basin - 19.69" (0.5m)	94631	94632	34.7	65.8
Series 600 optional riser	99902		9.8	10.0
Foul air trap - fits both 901 & 600 basins	90854		-	1.2

* Volume is up to grate seat and without trash bucket.

Foul air trap

Available K100/KS100 DrainLok™ grates

Description	Part No.	Length inches (m)	Slot Size inches	Intake area sq. in.	Wgt lbs	DL	Handicap	SAFT	Bicycle	Anti-slip
A Load Class A - 3,500lbs - EN 1433 70psi Pedestrian										

Perforated steel

Type 410D - galvanized	12666	39.37" (1.0m)	0.25 dia.	28.3	6.3	DL	✓	✓	✓	✓
Type 412D - galvanized	12667	19.69" (0.5m)		14.1	3.2					
Type 451D - stainless*	12664	39.37" (1.0m)	0.25 dia.	28.3	6.3	DL	✓	✓	✓	✓
Type 453D - stainless*	12665	19.69" (0.5m)		14.1	3.2					

* Grade 304 stainless steel

Slotted steel

Type 420D - galvanized	12610	39.37" (1.0m)	0.38 x 1.46 avg	35.2	5.9	DL	✗	✗	✗	✓
Type 421D - galvanized	12611	19.69" (0.5m)		17.6	3.0					
Type 450D - stainless*	12640	39.37" (1.0m)	0.38 x 1.46 avg	35.2	2.9	DL	✗	✗	✗	✓
Type 452D - stainless*	12641	19.69" (0.5m)		17.6	3.0					

* Grade 304 stainless steel

Longitudinal plastic

Type 494D - black	99575									
Type 495D - gray	99576	19.69" (0.5m)	1.76 x 0.34	27.4	1.8	DL	✓	✗	✗	✓
Type 496D - tan	99577									

Polypropylene

B Load Class B - 28,000lbs - EN 1433 581psi Light duty										
---	--	--	--	--	--	--	--	--	--	--

Longitudinal stainless steel

Type 447D - stainless	142215	39.37" (1.0m)	1.61 x 0.24	93.7	8.0	DL	✓	✓	✓	✓
Type 448D - stainless	142216	19.69" (0.5m)		46.9	4.0					

Grade 304 stainless steel

Longitudinal galvanized steel

Type 438D - galvanized	132555	39.37" (1.0m)	1.15 x 0.3	66.0	10.0	DL	✓	✓	✗	✓
Type 437D - galvanized	132550	19.69" (0.5m)		33.0	4.2					

C Load Class C - 56,000lbs - EN 1433 1,162psi Commercial vehicle										
---	--	--	--	--	--	--	--	--	--	--

Slotted plastic

Type 492D - black**	132720									
Type 497D - gray	132266	19.69" (0.5m)	0.3 x 1.69 avg	22.2	2.2	DL	✗	✓	✗	✓
Type 498D - tan	132712									

Polypropylene ** Microgrip texture (black only)

Slotted steel

Type 425D - galvanized	12614	39.37" (1.0m)	0.38 x 1.46 avg	35.2	8.8	DL	✗	✗	✗	✓
Type 426D - galvanized	12615	19.69" (0.5m)		17.6	4.4					
Type 455D - stainless*	12644	39.37" (1.0m)	0.38 x 1.46 avg	35.2	8.8	DL	✗	✗	✗	✓
Type 457D - stainless*	12645	19.69" (0.5m)		17.6	4.4					

* Grade 304 stainless steel

- Key**
- Locking mechanism
 - Compliant with Americans with Disabilities Act of 1990 Section 4.5.4 (Page 140)
 - ASME A112.6.3 - 2001 Heel resistant less than 0.31" (8mm) (Page 140)
 - Bicycle Safe compliant to Australian Standard AS 3996 - 2006 (Page 140)
 - Anti-slip grates - BPN over 24 (Page 140)

Heel safe equal or less than 0.25" (6.5mm) (Page 140)



Description	Part No.	Length inches (m)	Slot Size inches	Intake area sq. in.	Wgt lbs	DL	Handicap	SAFT	Bicycle	Anti-slip
C Load Class C - 56,000lbs - EN 1433 1,162psi Commercial vehicle										

Perforated steel

Type 411D - galvanized	12656	39.37" (1.0m)	0.25 dia.	28.3	11.3	DL	✓	✓	✓	✓
Type 413D - galvanized	12657	19.69" (0.5m)		14.1	5.7					
Type 465D - stainless*	12654	39.37" (1.0m)	0.25 dia.	28.3	11.3	DL	✓	✓	✓	✓
Type 466D - stainless*	12655	19.69" (0.5m)		14.1	5.7					

* Grade 304 stainless steel

Mesh steel

Type 405D - galvanized	132880	39.37" (1.0m) 19.69" (0.5m)	1.20 x 0.50	121.1	7.8	DL	✓	✗	✗	✓
Type 406D - galvanized	132881			58.0	3.9					
Type 430D - stainless*	132882	39.37" (1.0m) 19.69" (0.5m)	1.20 x 0.50	121.1	7.8	DL	✓	✗	✗	✓
Type 431D - stainless*	132883			58.0	3.9					

* Grade 304 stainless steel

Slotted iron

Type 460D - iron	12670	19.69" (0.5m)	0.47 x 1.58 avg	28.3	10.1	DL	✗	✗	✗	✓
------------------	-------	---------------	-----------------	------	------	----	---	---	---	---

Ductile iron to ASTM A 536-84 - minimum grade 64-45-12

Longitudinal iron

Type 476D - iron	142171	19.69" (0.5m)	2.1 x 0.24	22.6	7.0	DL	✓	✓	✓	✓
------------------	--------	---------------	------------	------	-----	----	---	---	---	---

Ductile iron to ASTM A 536-84 - minimum grade 64-45-12

Wave iron

Type 480D - iron	99578	19.69" (0.5m)	0.27 x 2.4 avg	27.0	8.0	DL	✓	✓	✗	✓
------------------	-------	---------------	----------------	------	-----	----	---	---	---	---

Ductile iron to ASTM A 536-84 - minimum grade 64-45-12

DrainLok™ - boltless & barless locking system

Fast locking device removes the need for bolts and bars and improves channels hydraulic capacity. The DrainLok™ mechanism simply clips into channel edge rail for rapid installation. ACO DrainLok™ grates are fitted with an anti-shunt mechanism that restricts unwanted grate movement when installed, improving durability and longevity of the system.



1 Fit grate

Position grate onto channel and align anti-shunt detail with recess in rail.

2 Push down

Push down or stand on grate until it clicks into position.

3 Grate removal

To remove first grate, insert grate removal tool into slots at end of grate, pull up sharply. Remaining grates can be removed by hand.

For QuickLok™ grates see next page



Available K100/KS100 QuickLok™ grates

Description	Part No.	Length inches (m)	Slot Size inches	Intake area sq. in.	Wgt lbs	QL	✓	✗	✓	✓	✓
C Load Class C - 56,000lbs - EN 1433 1,162psi Commercial vehicle											

Deco iron

Type 481Q - iron	97120	19.69" (0.5m)	0.44 x 0.6 avg	19.0	9.0	QL	✓	✗	✗	✓	38.8
Ductile iron to ASTM A 536-84 - minimum grade 64-45-12											

Mosaic iron

Type 479Q - iron	97116	19.69" (0.5m)	0.43 avg	13.0	10.0	QL	✓	✗	✗	✓	24.6
Ductile iron to ASTM A 536-84 - minimum grade 64-45-12											

E Load Class E - 135,000lbs - EN 1433 2,788psi Industrial											
--	--	--	--	--	--	--	--	--	--	--	--

Slotted iron

Type 461Q - iron	96752	19.69" (0.5m)	0.40 x 3.93	34.1	10.2	QL	✗	✗	✗	✓	31.1
Ductile iron to ASTM A 536-84 - minimum grade 64-45-12											

Slotted steel

Type 435Q - galvanized	31550	39.37" (1.0m)	0.38 x 1.46 avg	35.2	13.7	QL	✗	✗	✗	✓	27.4
Type 436Q - galvanized	31551	19.69" (0.5m)		17.6	6.8						
Type 490Q - stainless*	31650	39.37" (1.0m)	0.38 x 1.46 avg	35.2	13.7	QL	✗	✗	✗	✓	29.9
Type 493Q - stainless*	31651	19.69" (0.5m)		17.6	6.8						
* Grade 304 stainless steel.											

Longitudinal iron

Type 478Q - iron	03314	19.69" (0.5m)	1.77 x 0.27	22.5	12.8	QL	✓	✓	✗	✓	25.8
Ductile iron to ASTM A 536-84 - minimum grade 64-45-12											

QuickLok™ - boltless locking system

1



Fit locking bar

Locate locking bar in channel wall recesses by rotating clockwise.

2



Fit grate

Use hammer to tap bar into place, so that serrated ends grip in recess.

3



Grate removal

To install grate, align QuickLok™ stud directly over locking bar.

4



Grate removal

Push down or stand on grate until it clicks into position.

5



Grate removal

To remove first grate, insert grate removal tool into slots at end of grate, pull up sharply. Remaining grates can be removed by hand.

6



Grate removal

To remove bar, insert screwdriver into hole at end of bar and lever back serrated end, rotate bar free.

Key	Locking mechanism	Compliant with Americans with Disabilities Act of 1990 Section 4.5.4 (Page 140)	ASME A112.6.3 - 2001 Heel resistant less than 0.31" (8mm) (Page 140)
	Heel safe equal or less than 0.25" (6.5mm) (Page 140)	Bicycle Safe compliant to Australian Standard AS 3996 - 2006 (Page 140)	Anti-slip grates - BPN over 24 (Page 140)

Description	Part No.	Length inches (m)	Slot Size inches	Intake area sq. in.	Wgt lbs	QL	✓	✗	✓	✓	✓
C Load Class C - 56,000lbs - EN 1433 1,162psi Commercial vehicle											

Steel Brickslot 100

Type 441 - galvanized	138040	39.37" (1.0m)	39.4 x 0.47	18.6	17.6	N/A	✓	✗	✗	✓	N/A
Type 442 - galvanized	138041	19.69" (0.5m)									
Type 443 stainless*	138045	39.37" (1.0m)	39.4 x 0.3	24.8	17.6	N/A	✓	✓	✗	✓	N/A
Type 444 stainless*	138046	19.69" (0.5m)									
* Grade 304 stainless steel. See page 58 for full details/access units.											

Steel Heel Resistant Brickslot 100

Type 470 - galvanized	138050	39.37" (1.0m)	39.4 x 0.3	24.8	18.0	N/A	✓	✓	✗	✓	N/A
Type 471 - galvanized	138051	19.69" (0.5m)									
Type 472 stainless*	138055	39.37" (1.0m)	39.4 x 0.3	24.8	18.0	N/A	✓	✓	✗	✓	N/A
Type 473 stainless*	138056	19.69" (0.5m)									
* Grade 304 stainless steel. See page 58 for full details/access units.											



Typical Brickslot use



KlassikDrain K200/ KS200

Key Dimensions

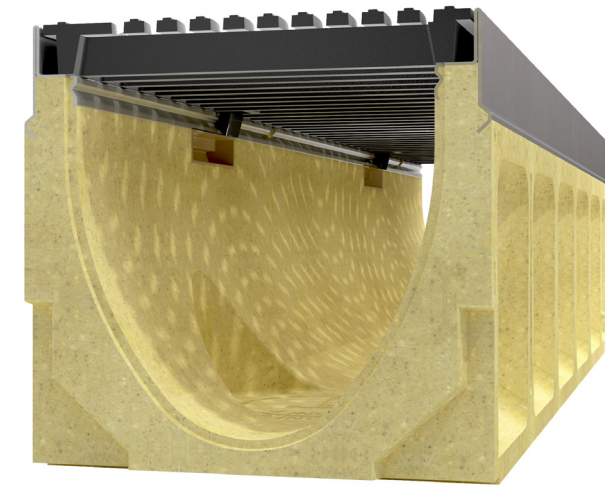
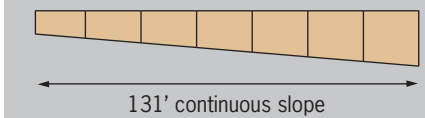
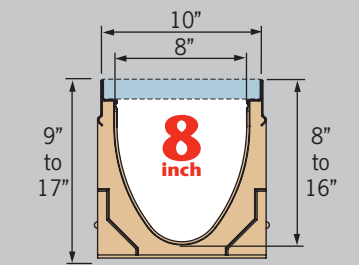

K200 is an 8" wide system with galvanized steel edge rail and wide choice of grates in different materials and slot styles up to Load Class E (60 ton) featuring either patented DrainLok™ or QuickLok™ boltless locking systems.

KS200 is the same system, but the edge rail is grade 304 stainless steel. KS200 should be used where increased aesthetics are required, or where increased corrosion resistance is required.

Typical applications

- Parking lots & garages
- Shopping malls
- Pedestrian areas
- Light industrial areas
- Commercial areas
- Internal applications

Selection criteria

- A B C D E** Light to industrial duty loads
- Product can be used towards LEED & EPA requirements
- Resistant to many everyday chemicals. *Check page 139*
- Multiple grate options to meet legal requirements
- Multiple grate options to meet design requirements
- Increased hydraulic capacity
- Constant depth and/or sloped depth channels



K200/KS200 - 8" wide general purpose system

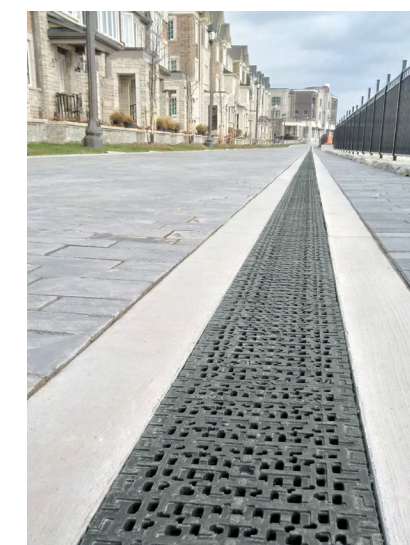
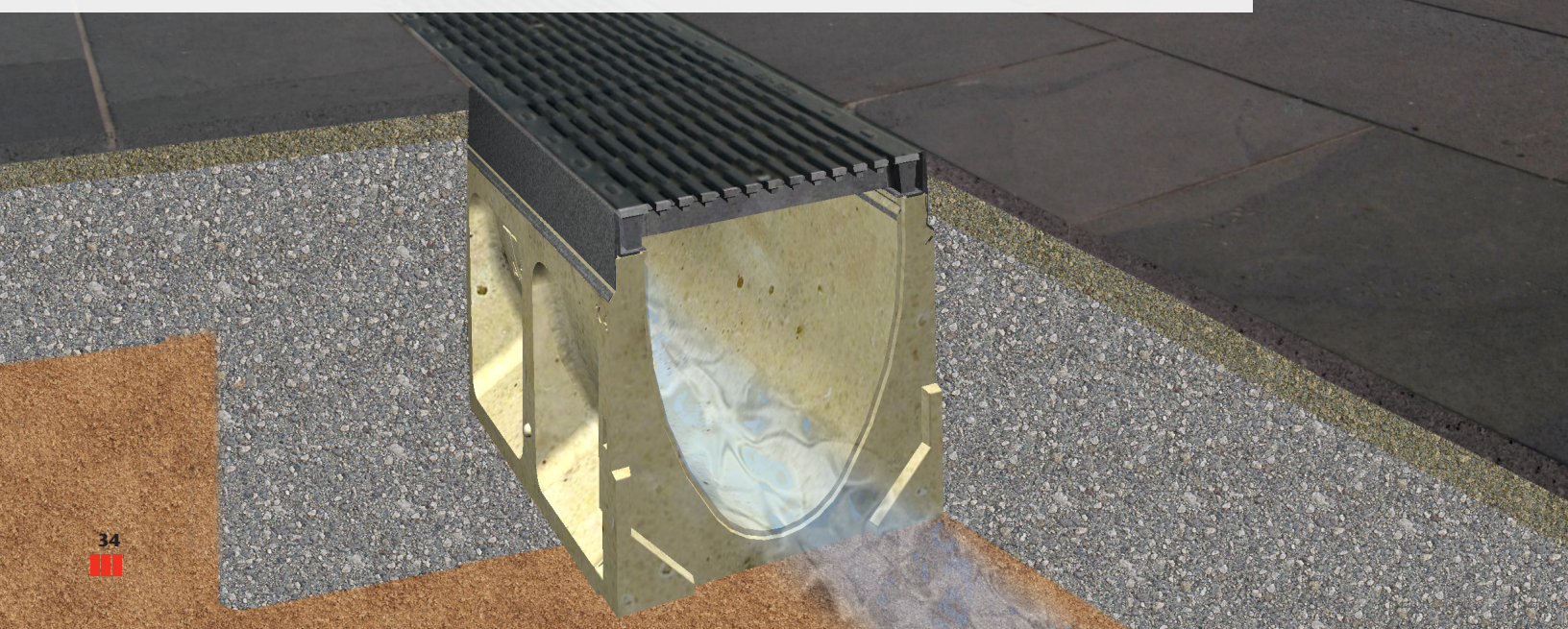

www.ACODrain.us

System layout

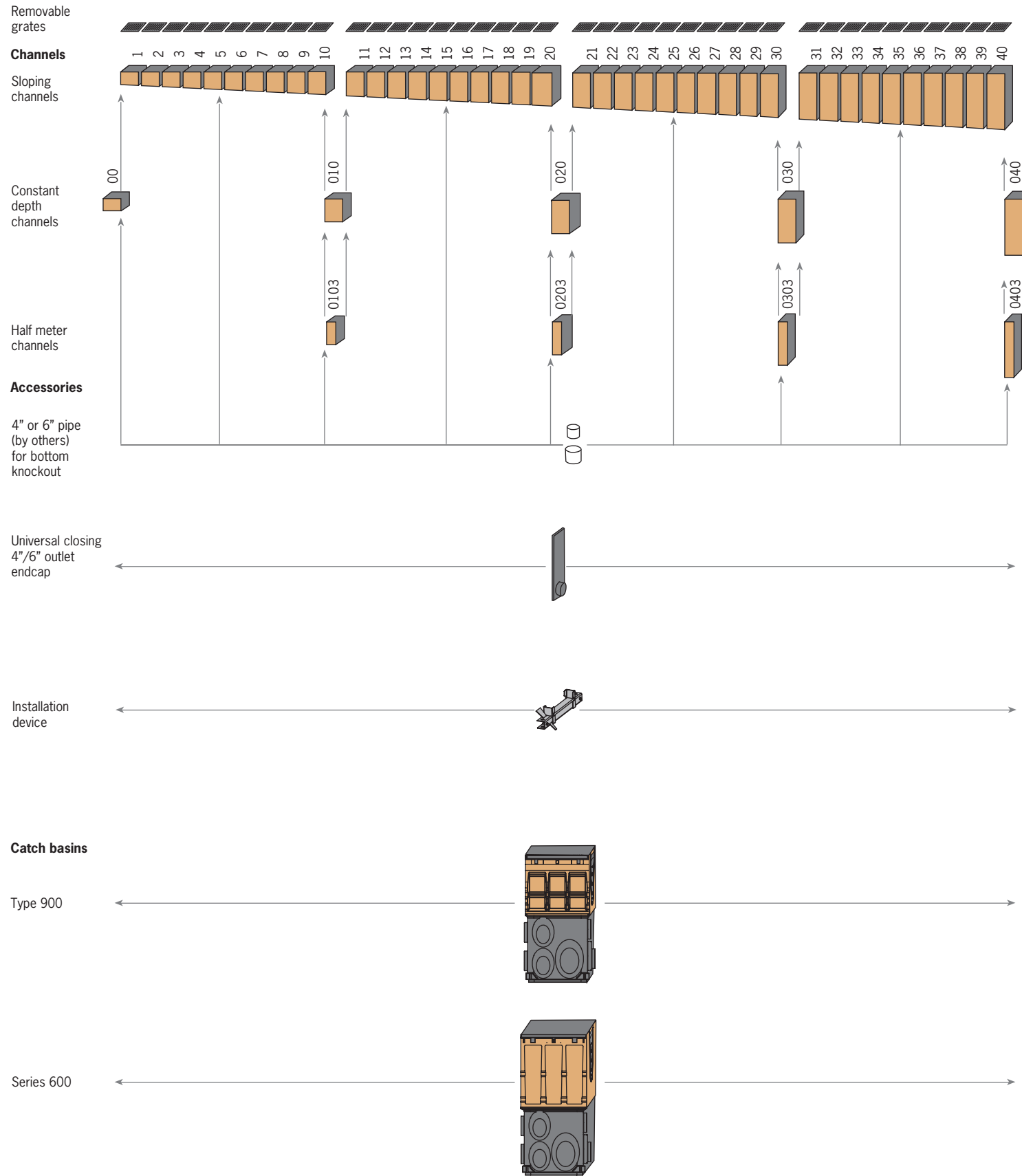

Meter channels - sloping & constant depth

0.5% sloped channels in meter lengths and 40 depths which connect to create 40 meter (131'-2") continuously sloping run. Available with either galvanized or stainless steel edge rail.

Constant depth channels are available in 5 depths. Can be used to create non-sloped runs, or inserted in sloped runs to increase length.

Bottom knockouts on all constant depths and 5, 10, 15, 20, 25, 30, 35, 40 channels.

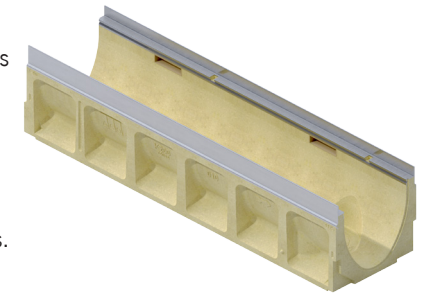

Half meter channels

Constant depth channels in 4 depths supplement meter channels. Side knockout and profiling enable side junction to be created. Bottom knockouts on all half meter channels. Available with either galvanized or stainless steel edge rail.

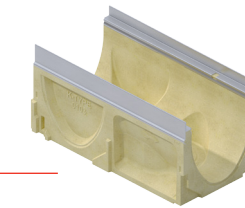

Closing/4 in. or 6 in. outlet cap

Fits all channels and manufactured from gray polypropylene to complement edge rail. Guides aid cutting to correct height. Wings clip cap onto end of channel. 4" and 6" bell end provides connection to Schedule 40 pipe. Seal using appropriate flexible sealant.

Note: For depth 1-10 channels, ACO recommends removal of unused sections of bell end to ensure adequate pavement material coverage.

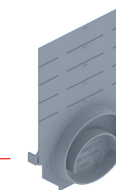

Installation device

Fits molded recesses on body of channel. Provides height and joint alignment - a sliding clamp locks the two channels together. Bolt to rebar on either side of channel to hold channels in place during concrete pour. Not reusable; it is 'lost' within concrete haunch.

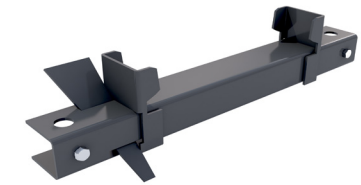

Type 902 In-line catch basin

Two part in-line catch basin with 4", 6" and 8" drill-outs for pipe connection. Supplied with plastic trash bucket. Options include an in-line or side foul air trap. Available with either galvanized or stainless steel edge rail.

Any channel can be connected into the catch basin by removing the end wall to the correct height with a box cutter. Cut-out guides provided for connection to channels 00, 010, 020, 030 and 040. All cut-outs to receive male channel ends.



Series 600 catch basin

Two part catch basin; bases have 4", 6" and 8" drill-outs for pipe connections. Supplied with plastic trash bucket. Optional riser available for increased depth. Contact ACO for non-polyethylene riser/bases. Available with either galvanized or stainless steel edge rail.

Any channel can be connected to catch basin by removing end/side wall to correct height. Cut-outs guide connection to channels 00, 010, 020, 030 and 040. All cut-outs to receive male channel ends. Blanking kit end rail available to stop concrete ingress during final pour.

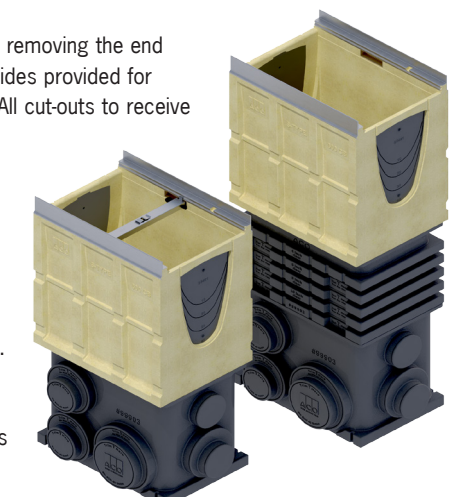

Meter channels

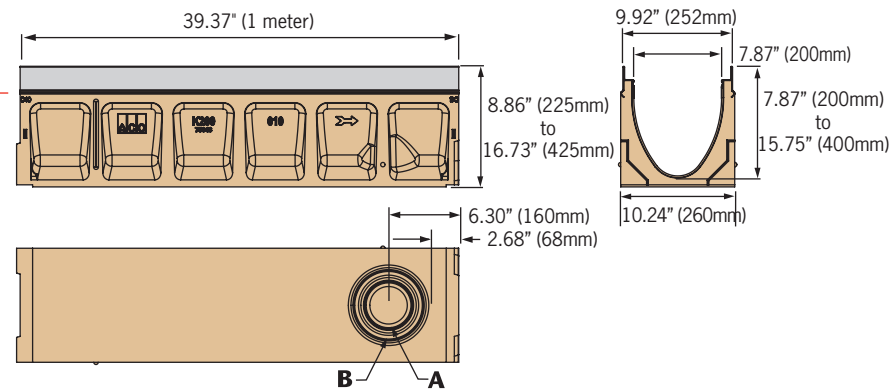

Half meter channels

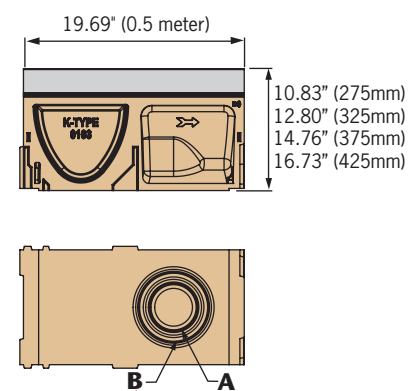

Outlet flow rates

Channels				
Outlet	Size (Sch 40)	Invert in.	GPM	CFS
A	K00 - 4" round	7.87"	153	0.34
A	K40 - 4" round	15.75"	216	0.48
B	K00 - 6" round	7.87"	344	0.77
B	K40 - 6" round	15.75"	486	1.08
C	K00 - 4" round	7.87"	132	0.29
C	K40 - 4" round	15.75"	202	0.45
D	K10 - 6" round	9.84"	320	0.71
D	K40 - 6" round	15.75"	437	0.97

Catch basins		K2-902G/S			K2-621G/S			K2-631G/S		
Outlet	Size (Sch 40)	Invert in.	GPM	CFS	Invert in.	GPM	CFS	Invert in.	GPM	CFS
a	4" round	25.33"	263	0.59	29.80"	287	0.64	41.80"	343	0.77
b	4" round	31.83"	297	0.66	36.29"	319	0.71	48.29"	370	0.83
c	4" round	23.76"	254	0.57	28.22"	279	0.62	40.22"	337	0.75
d	6" round	31.83"	658	1.47	36.29"	707	1.57	48.29"	824	1.84
e	4" round	23.91"	255	0.57	28.37"	280	0.62	40.37"	337	0.75
f	4" round	30.40"	290	0.65	34.87"	312	0.70	46.87"	365	0.81
g	6" round	24.68"	570	1.27	29.15"	626	1.40	41.15"	757	1.69
h	4" round	24.13"	256	0.57	28.59"	281	0.63	40.59"	338	0.75
i	6" round	31.82"	658	1.47	36.28"	707	1.57	48.28"	824	1.84
j	4" round	31.26"	294	0.66	35.72"	316	0.70	47.72"	368	0.82
k	6" round	31.26"	651	1.45	35.72"	701	1.56	47.72"	819	1.83
l	8" round	31.82"	1149	2.56	36.28"	1237	2.76	48.28"	1449	3.23
m	6" round	30.32"	640	1.43	34.78"	690	1.54	46.78"	810	1.81
n	4" round	23.19"	251	0.56	27.65"	276	0.61	39.65"	334	0.74
o	4" round	29.90"	288	0.64	34.36"	310	0.69	46.36"	363	0.81

Note: These are pipe flow rates at specified outlet, **NOT** channel flow rates. Catch basin flow rates without trash bucket - using trash bucket reduces flow.

Closing/4 in. or 6 in. outlet cap

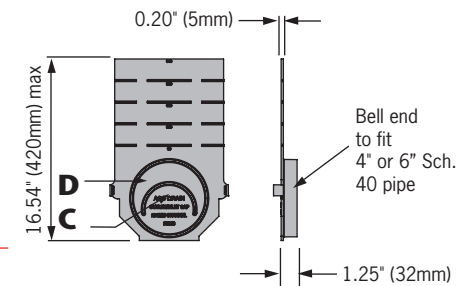

Installation device

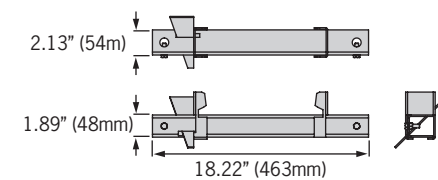

K2-902G/S In-line catch basin

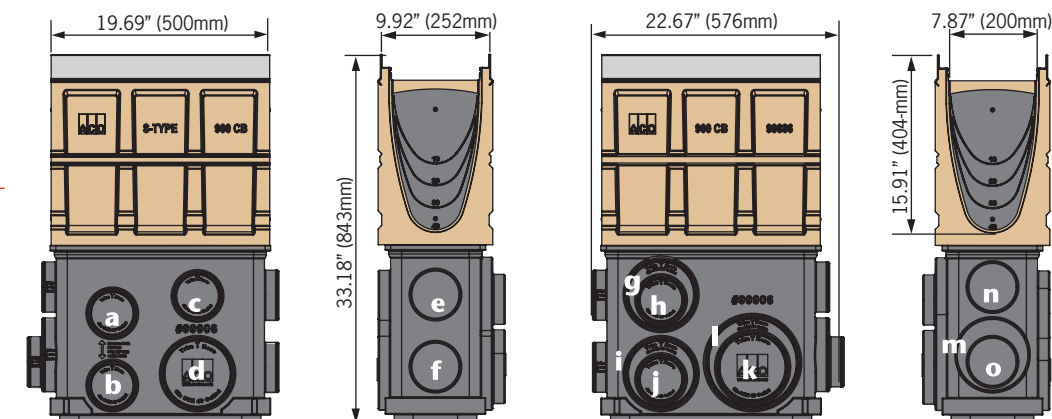

K2-621G/S catch basin

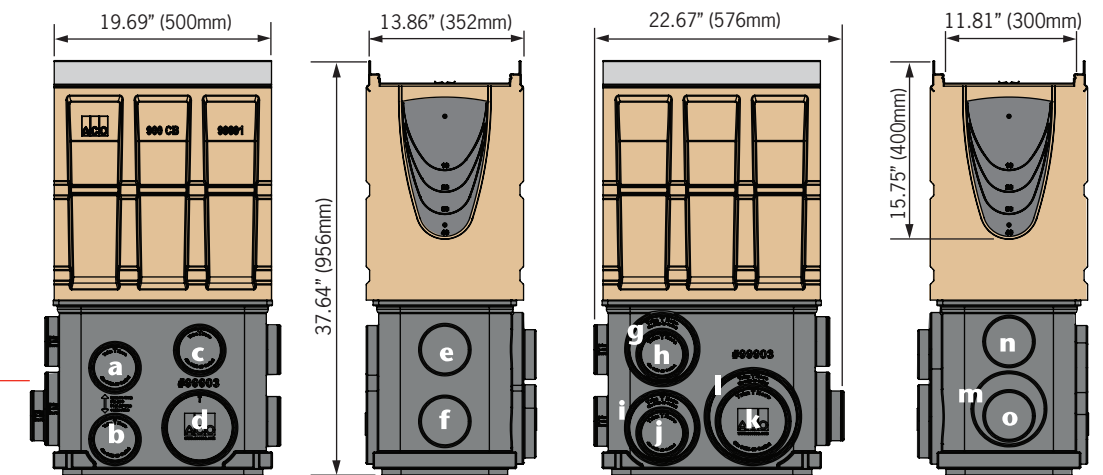

K2-631G/S catch basin

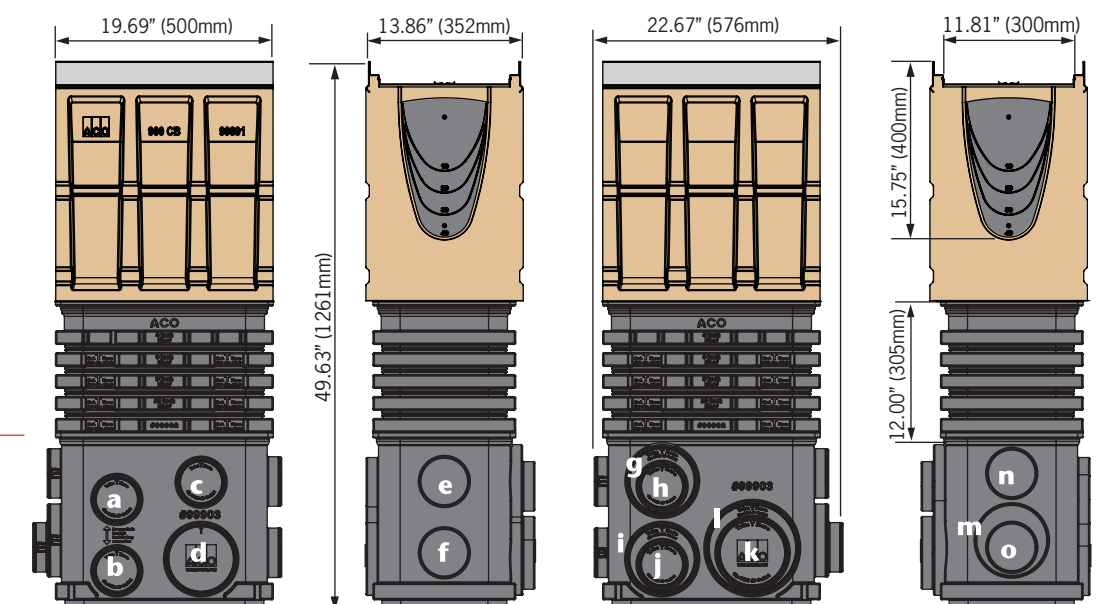

K200/KS200 Parts table

	Part No.		Invert Depth				Overall Depth				Vol	Wgt
	K200	KS200	Inches		mm		Inches		mm		Gal	lbs
			female	male	female	male	female	male	female	male		
K2-00 Constant depth channel - 39.37" (1m) ³	75041	75441	7.87	7.87	200	200	8.86	8.86	225	225	7.54	83.6
K2-1 Sloped channel - 39.37" (1m)	75001	75401	7.87	8.07	200	205	8.86	9.06	225	230	7.94	83.6
K2-2 Sloped channel - 39.37" (1m)	75002	75402	8.07	8.27	205	210	9.06	9.25	230	235	8.13	84.7
K2-3 Sloped channel - 39.37" (1m)	75003	75403	8.27	8.46	210	215	9.25	9.45	235	240	8.33	85.8
K2-4 Sloped channel - 39.37" (1m)	75004	75404	8.46	8.66	215	220	9.45	9.65	240	245	8.53	86.9
K2-5 Sloped channel - 39.37" (1m) ³	75005	75405	8.66	8.86	220	225	9.65	9.84	245	250	8.74	88.0
K2-6 Sloped channel - 39.37" (1m)	75006	75406	8.86	9.06	225	230	9.84	10.04	250	255	8.95	89.1
K2-7 Sloped channel - 39.37" (1m)	75007	75407	9.06	9.25	230	235	10.04	10.24	255	260	9.16	90.2
K2-8 Sloped channel - 39.37" (1m)	75008	75408	9.25	9.45	235	240	10.24	10.43	260	265	9.37	91.3
K2-9 Sloped channel - 39.37" (1m)	75009	75409	9.45	9.65	240	245	10.43	10.63	265	270	9.58	92.4
K2-10 Sloped channel - 39.37" (1m) ³	75010	75410	9.65	9.84	245	250	10.63	10.83	270	275	9.79	93.5
K2-010 Constant depth channel - 39.37" (1m) ³	75043	75443	9.84	9.84	250	250	10.83	10.83	275	275	9.59	93.5
K2-0103 Constant depth channel - 19.69" (0.5m) ³	75044	75444	9.84	9.84	250	250	10.83	10.83	275	275	4.80	56.0
K2-11 Sloped channel - 39.37" (1m)	75011	75411	9.84	10.04	250	255	10.83	11.02	275	280	10.01	94.6
K2-12 Sloped channel - 39.37" (1m)	75012	75412	10.04	10.24	255	260	11.02	11.22	280	285	10.22	95.7
K2-13 Sloped channel - 39.37" (1m)	75013	75413	10.24	10.43	260	265	11.22	11.42	285	290	10.44	96.8
K2-14 Sloped channel - 39.37" (1m)	75014	75414	10.43	10.63	265	270	11.42	11.61	290	295	10.66	97.9
K2-15 Sloped channel - 39.37" (1m) ³	75015	75415	10.63	10.83	270	275	11.61	11.81	295	300	10.88	99.0
K2-16 Sloped channel - 39.37" (1m)	75016	75416	10.83	11.02	275	280	11.81	12.01	300	305	11.10	100.1
K2-17 Sloped channel - 39.37" (1m)	75017	75417	11.02	11.22	280	285	12.01	12.20	305	310	11.32	101.2
K2-18 Sloped channel - 39.37" (1m)	75018	75418	11.22	11.42	285	290	12.20	12.40	310	315	11.54	102.3
K2-19 Sloped channel - 39.37" (1m)	75019	75419	11.42	11.61	290	295	12.40	12.60	315	320	11.76	103.4
K2-20 Sloped channel - 39.37" (1m) ³	75020	75420	11.61	11.81	295	300	12.60	12.80	320	325	11.98	104.5
K2-020 Constant depth channel - 39.37" (1m) ³	75045	75445	11.81	11.81	300	300	12.80	12.80	325	325	11.78	104.5
K2-0203 Constant depth channel - 19.69" (0.5m) ³	75046	75446	11.81	11.81	300	300	12.80	12.80	325	325	5.89	64.0
K2-21 Sloped channel - 39.37" (1m)	75021	75421	11.81	12.01	300	305	12.80	12.99	325	330	12.21	105.6
K2-22 Sloped channel - 39.37" (1m)	75022	75422	12.01	12.20	305	310	12.99	13.19	330	335	12.42	106.7
K2-23 Sloped channel - 39.37" (1m)	75023	75423	12.20	12.40	310	315	13.19	13.39	335	340	12.65	107.8
K2-24 Sloped channel - 39.37" (1m)	75024	75424	12.40	12.60	315	320	13.39	13.58	340	345	12.87	108.9
K2-25 Sloped channel - 39.37" (1m) ³	75025	75425	12.60	12.80	320	325	13.58	13.78	345	350	13.10	110.0
K2-26 Sloped channel - 39.37" (1m)	75026	75426	12.80	12.99	325	330	13.78	13.98	350	355	13.32	111.1
K2-27 Sloped channel - 39.37" (1m)	75027	75427	12.99	13.19	330	335	13.98	14.17	355	360	13.56	112.2
K2-28 Sloped channel - 39.37" (1m)	75028	75428	13.19	13.39	335	340	14.17	14.37	360	365	13.77	113.3
K2-29 Sloped channel - 39.37" (1m)	75029	75429	13.39	13.58	340	345	14.37	14.57	365	370	13.99	114.4
K2-30 Sloped channel - 39.37" (1m) ³	75030	75430	13.58	13.78	345	350	14.57	14.76	370	375	14.22	115.5
K2-030 Constant depth channel - 39.37" (1m) ³	75047	75447	13.78	13.78	350	350	14.76	14.76	375	375	14.01	115.5
K2-0303 Constant depth channel - 19.69" (0.5m) ³	75048	75448	13.78	13.78	350	350	14.76	14.76	375	375	7.05	68.0
K2-31 Sloped channel - 39.37" (1m)	75031	75431	13.78	13.98	350	355	14.76	14.96	375	380	14.44	116.6
K2-32 Sloped channel - 39.37" (1m)	75032	75432	13.98	14.17	355	360	14.96	15.16	380	385	14.67	117.7
K2-33 Sloped channel - 39.37" (1m)	75033	75433	14.17	14.37	360	365	15.16	15.35	385	390	14.89	118.8
K2-34 Sloped channel - 39.37" (1m)	75034	75434	14.37	14.57	365	370	15.35	15.55	390	395	15.11	119.9
K2-35 Sloped channel - 39.37" (1m) ³	75035	75435	14.57	14.76	370	375	15.55	15.75	395	400	15.34	121.0
K2-36 Sloped channel - 39.37" (1m)	75036	75436	14.76	14.96	375	380	15.75	15.94	400	405	15.56	122.1
K2-37 Sloped channel - 39.37" (1m)	75037	75437	14.96	15.16	380	385	15.94	16.14	405	410	15.78	123.2
K2-38 Sloped channel - 39.37" (1m)	75038	75438	15.16	15.35	385	390	16.14	16.34	410	415	16.02	124.3
K2-39 Sloped channel - 39.37" (1m)	75039	75439	15.35	15.55	390	395	16.34	16.54	415	420	16.23	125.4
K2-40 Sloped channel - 39.37" (1m) ³	75040	75440	15.55	15.75	395	400	16.54	16.73	420	425	16.46	126.5
K2-040 Constant depth channel - 39.37" (1m) ³	75049	75449	15.75	15.75	400	400	16.73	16.73	425	425	16.27	126.5
K2-0403 Constant depth channel - 19.69" (0.5m) ³	75050	75450	15.75	15.75	400	400	16.73	16.73	425	425	8.14	77.0
K2 Universal end/ 4" & 6" inlet/outlet cap	96821		15.75	15.75	400	400	16.54	16.54	420	420	-	1.4
Debris strainer for 4" bottom knockout	93488		-	-	-	-	-	-	-	-	-	0.2
Installation device	97478		-	-	-	-	-	-	-	-	-	4.0
Grate removal tool	01318		-	-	-	-	-	-	-	-	-	0.3
QuickLok™ locking bar	10457		-	-	-	-	-	-	-	-	-	0.5

- Notes:**
1. K200 has a galvanized steel edge rail for general use. KS200 has a grade 304 stainless steel edge rail for use where increased aesthetics or corrosion resistance is required.
 2. KlassikDrain is sold as channel only. Choose appropriate grate from pages 42-43.
 3. Preformed 4" & 6" dia. drill-outs cast on underside of certain channels (00, 5, 10, 010, 0103, 15, 20, 020, 0203, 25, 30, 030, 0303, 35, 40, 040, 0403).
 4. Closing/outlet cap can be cut down to suit all channels.
 5. Catch basin details on page 41.
 6. Debris strainer details for 4" dia. outlet on page 103.

Polymer concrete catch basins

Polymer concrete catch basins are used either as stand alone area drains or more commonly as the outlet to a trench run. They provide the highest hydraulic output and allow easy access to pipe system for maintenance.

Type 900 provides an in-line catch basin (same width and visually indistinguishable from the trench run) and the Series 600 is 12" wide and provides greater a hydraulic output.

K2-Series 600
12 in. wide catch basin (with riser)

K2-Type 902
8 in. wide In-line catch basin

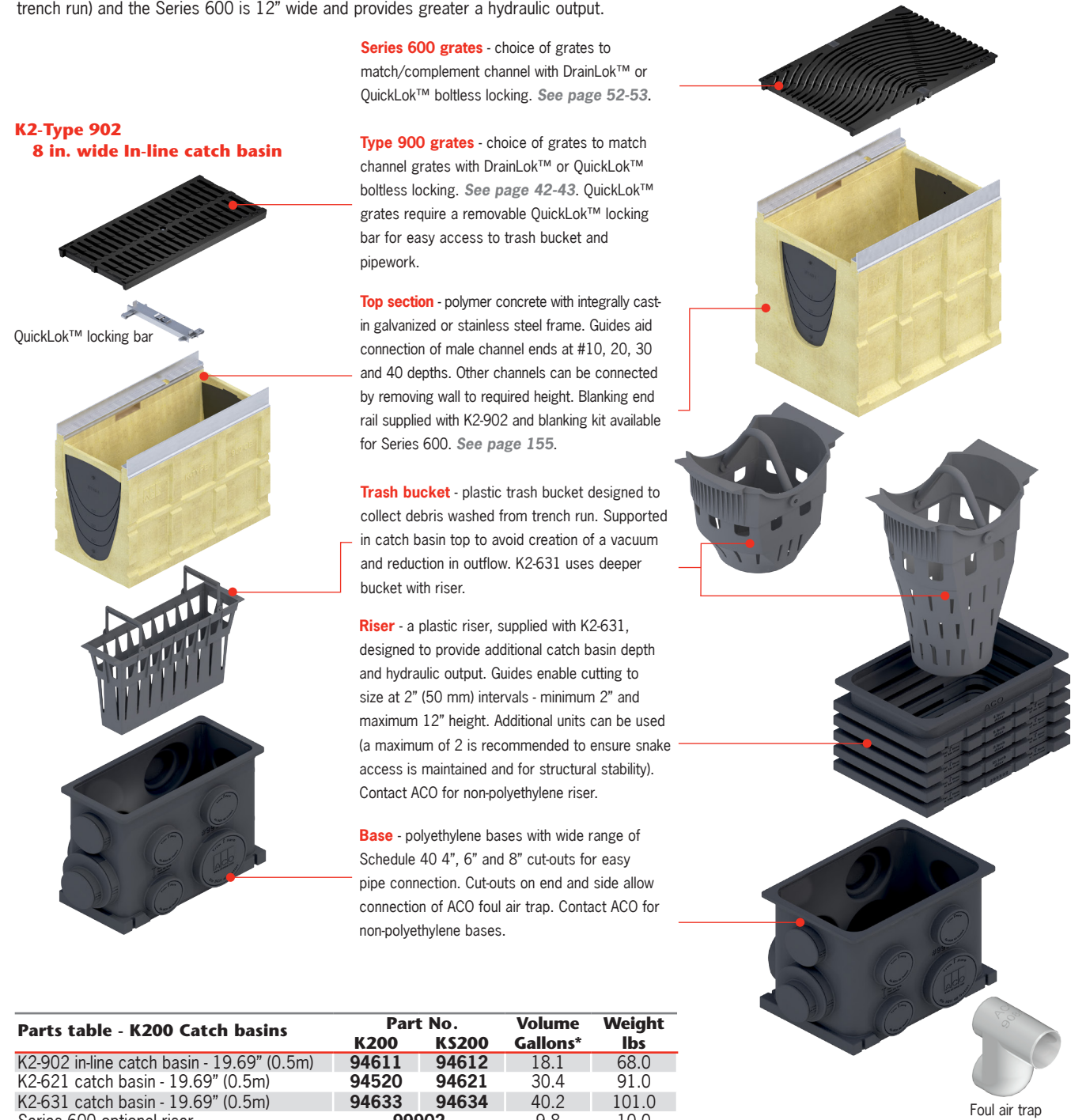

Series 600 grates - choice of grates to match/complement channel with DrainLok™ or QuickLok™ boltless locking. *See page 52-53.*

Type 900 grates - choice of grates to match channel grates with DrainLok™ or QuickLok™ boltless locking. *See page 42-43.* QuickLok™ grates require a removable QuickLok™ locking bar for easy access to trash bucket and pipework.

Top section - polymer concrete with integrally cast-in galvanized or stainless steel frame. Guides aid connection of male channel ends at #10, 20, 30 and 40 depths. Other channels can be connected by removing wall to required height. Blanking end rail supplied with K2-902 and blanking kit available for Series 600. *See page 155.*

Trash bucket - plastic trash bucket designed to collect debris washed from trench run. Supported in catch basin top to avoid creation of a vacuum and reduction in outflow. K2-631 uses deeper bucket with riser.

Riser - a plastic riser, supplied with K2-631, designed to provide additional catch basin depth and hydraulic output. Guides enable cutting to size at 2" (50 mm) intervals - minimum 2" and maximum 12" height. Additional units can be used (a maximum of 2 is recommended to ensure snake access is maintained and for structural stability). Contact ACO for non-polyethylene riser.

Base - polyethylene bases with wide range of Schedule 40 4", 6" and 8" cut-outs for easy pipe connection. Cut-outs on end and side allow connection of ACO foul air trap. Contact ACO for non-polyethylene bases.

Parts table - K200 Catch basins	Part No.		Volume Gallons*	Weight lbs
	K200	KS200		
K2-902 in-line catch basin - 19.69" (0.5m)	94611	94612	18.1	68.0
K2-621 catch basin - 19.69" (0.5m)	94520	94621	30.4	91.0
K2-631 catch basin - 19.69" (0.5m)	94633	94634	40.2	101.0
Series 600 optional riser		99902	9.8	10.0
Foul air trap - fits both 902 & 600 basins		90854	-	1.2

* Volume is up to grate seat and without trash bucket.

Available K200/KS200 DrainLok™ grates

Description	Part No.	Length inches (m)	Slot Size inches	Intake area sq. in.	Wgt lbs	DL	Handicap	SAFETY	SAFETY	SAFETY
B Load Class B - 28,000lbs - EN 1433 483psi Light duty										
Longitudinal stainless										
Type 647D - stainless	142219	39.37" (1.0m)	1.61 x 0.24	178.2	17.7	DL	✓	✓	✓	51.3
Type 648D - stainless	142220	19.69" (0.5m)		89.1	9.0					
Grade 304 stainless steel										
C Load Class C - 56,000lbs - EN 1433 967psi Commercial vehicle										
Perforated steel										
Type 611D - galvanized	138080	39.37" (1.0m)	0.25 dia.	44.6	21.0	DL	✓	✓	✓	22.6
Type 613D - galvanized	138081	19.69" (0.5m)		22.3	10.5					
Type 665D - stainless*	138082	39.37" (1.0m)	0.25 dia.	44.6	21.0	DL	✓	✓	✓	29.6
Type 666D - stainless*	138083	19.69" (0.5m)		22.3	10.5					
* Grade 304 stainless steel										
Slotted iron										
Type 660D - iron	142177	19.69" (0.5m)	0.47 x 2.6	56.4	18.0	DL	✗	✗	✗	21.4
Ductile iron to ASTM A 536-84 - minimum grade 64-45-12										
Longitudinal iron										
Type 676D - iron	142173	19.69" (0.5m)	2.07 x 0.24	35.8	18.0	DL	✓	✓	✓	25.8
Ductile iron to ASTM A 536-84 - minimum grade 64-45-12										
Wave iron										
Type 680D - iron	99579	19.69" (0.5m)	0.27 x 0.9 avg	58.1	28.0	DL	✓	✓	✗	26.6
Ductile iron to ASTM A 536-84 - minimum grade 64-45-12										

DrainLok™ - boltless & barless locking system



1

Fit grate

Position grate onto channel, align anti-shunt detail with recess in rail.



2

Fit grate

Push down or stand on grate until it clicks into position.







3

Grate removal

To remove first grate, insert grate removal tool into slots at end of grate, pull up sharply. Remaining grates can be removed by hand.

- Key**
- Locking mechanism
 - Compliant with Americans with Disabilities Act of 1990 Section 4.5.4 (Page 140)
 - ASME A112.6.3 - 2001 Heel resistant less than 0.31" (8mm) (Page 140)
 - Heel safe equal or less than 0.25" (6.5mm) (Page 140)
 - Bicycle Safe compliant to Australian Standard AS 3996 - 2006 (Page 140)
 - Anti-slip grates - BPN over 24 (Page 140)

Available K200/KS200 QuickLok™ grates

Description	Part No.	Length inches (m)	Slot Size inches	Intake area sq. in.	Wgt lbs	DL	Handicap	SAFETY	SAFETY	SAFETY	
C Load Class C - 56,000lbs - EN 1433 967psi Commercial vehicle											
Mesh steel											
Type 605Q - galvanized	10352	39.37" (1.0m)	0.66 x 1.22	256	31.7	QL	✗	✗	✗	52.1	
Type 606Q - galvanized	10353	19.69" (0.5m)		128	16.1						
Type 630Q - stainless*	16032	39.37" (1.0m)	0.66 x 1.22	256	31.7	QL	✗	✗	✗	41.3	
Type 631Q - stainless*	16033	19.69" (0.5m)		128	16.1						
* Grade 304 stainless steel											
Decorative iron											
Type 681Q - iron	93956	19.69" (0.5m)	0.29 x 0.43 avg	29.1	27.0	QL	✓	✗	✗	38.8	
Ductile iron to ASTM A 536-84 - minimum grade 64-45-12											
Mosaic iron											
Type 679Q - iron	93957	19.69" (0.5m)	0.30 x 0.98 avg.	38.3	34.0	QL	✓	✗	✗	24.6	
Ductile iron to ASTM A 536-84 - minimum grade 64-45-12											
E Load Class E - 135,000lbs - EN 1433 2,321psi Industrial											
Longitudinal iron											
Type 678Q - iron	138129	19.69" (0.5m)	1.41 x 0.31	51.6	26.0	QL	✓	✓	✓	25.8	
Ductile iron to ASTM A 536-84 - minimum grade 64-45-12											
Slotted iron											
Type 661Q - iron	10351	19.69" (0.5m)	0.39 x 3.75	81.9	37.0	QL	✗	✗	✗	59.9	
Ductile iron to ASTM A 536-84 - minimum grade 64-45-12											
QuickLok™ - boltless locking system											
1			2			3			4		
											
Fit locking bar			Fit grate			Grate removal			Grate removal		
Locate locking bar in recesses, rotate and use hammer to tap securely into place. Serrated ends grip in recess.			K200 channels use plastic safety clip to hold in place.			To install grate, align QuickLok™ stud directly over locking bar.			Push down or stand on grate until it clicks into position.		
						To remove first grate, insert grate removal tool into slots at end of grate, pull up sharply. Remaining grates can be removed by hand.			To remove bar, insert screwdriver into hole at end of bar and lever back serrated end; rotate bar free.		
C Load Class C - 56,000lbs - EN 1433 967psi Commercial vehicle											
Steel Brickslot 200											
Type 641 - galvanized	138060	39.37" (1.0m)	39.4 x 0.47	37.2	36.3	N/A	✓	✗	✗	NA	
Type 642 - galvanized	138061	19.69" (0.5m)			18.7						
Type 643 - stainless*	138065	39.37" (1.0m)			36.3						
Type 644 - stainless*	138066	19.69" (0.5m)			18.7						
Steel Heel Resistant Brickslot 200											
Type 670 - galvanized	138070	39.37" (1.0m)	39.4 0.3	24.8	28.2	N/A	✓	✓	✗	NA	
Type 672 - galvanized	138071	19.69" (0.5m)			14.5						
Type 673 - stainless*	138075	39.37" (1.0m)			28.2						
Type 674 - stainless*	138076	19.69" (0.5m)			14.5						
* Grade 304 stainless steel. See page 58 for full details/access units.											



K300/KS300 - 12" wide general purpose system

KlassikDrain K300/ KS300

Key Dimensions

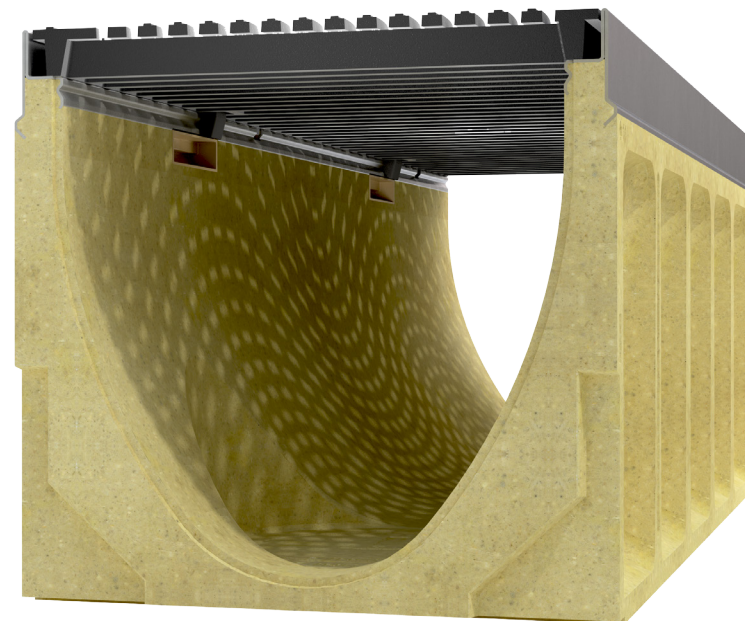
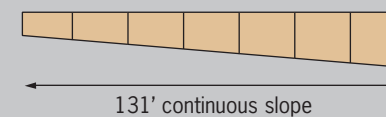
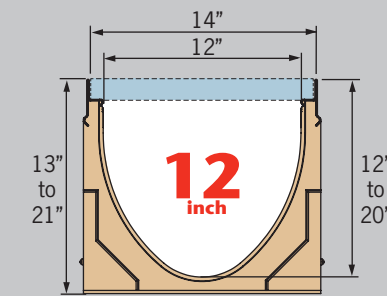

K300 is a 12" wide system with galvanized steel edge rail and wide choice of grates in different materials and slot styles up to Load Class E (60 ton) featuring either patented DrainLok™ or QuickLok™ boltless locking systems.

KS300 is the same system, but the edge rail is grade 304 stainless steel. KS300 should be used where increased aesthetics are required, or where increased corrosion resistance is required.

Typical applications

- Parking lots & garages
- Shopping malls
- Pedestrian areas
- Light industrial areas
- Commercial areas
- Internal applications

Selection criteria

- Light to industrial duty loads
- Product can be used towards LEED & EPA requirements
- Resistant to many everyday chemicals. *Check page 139*
- Multiple grate options to meet legal requirements
- Multiple grate options to meet design requirements
- Maximum hydraulic capacity
- Constant depth and/or sloped depth channels



System layout

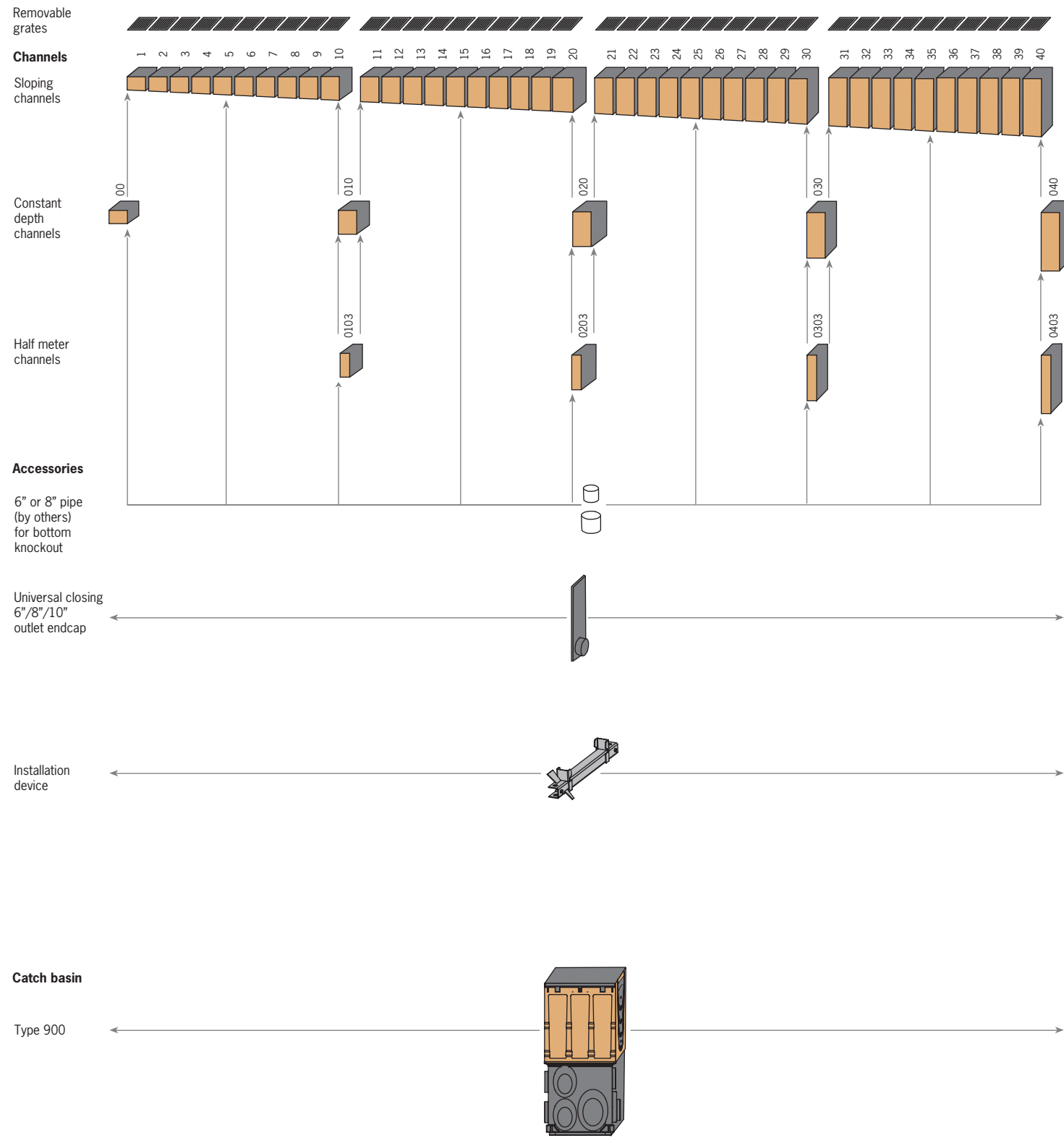

Meter channels - sloping & constant depth

0.5% sloped channels in meter lengths and 40 depths which connect to create 40 meter (131'-2") continuously sloping run. Available with either galvanized or stainless steel edge rail.

Constant depth channels are available in 5 depths. Can be used to create non-sloped runs, or inserted in sloped runs to increase length.

Bottom knockouts on all constant depths and 5, 10, 15, 20, 25, 30, 35, 40 channels.

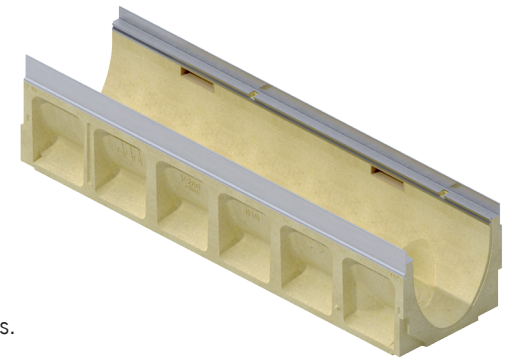

Half meter channels

Constant depth channels in 4 depths supplement meter channels. Side knockout and profiling enable side junction to be created. Bottom knockouts on all half meter channels. Available with either galvanized or stainless steel edge rail.

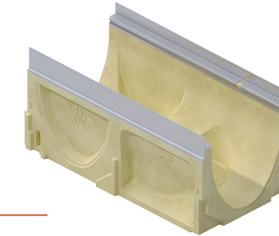

Closing/6 in., 8 in. or 10 in. outlet cap

Fits all channels are manufactured from gray polypropylene to complement edge rail. Guides aid cutting to correct height. Wings clip cap onto end of channel. 6", 8" and 10" bell end provides connection to Schedule 40 pipe. Seal using appropriate flexible sealant.

Note: For depth 1-10 channels, ACO recommends removal of unused sections of bell end to ensure adequate pavement material coverage.

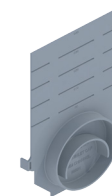

Installation device

Fits molded recesses on body of channel. Provides height and joint alignment - a sliding clamp locks the two channels together. Bolt to rebar on either side of channel to hold channels in place during concrete pour. Not reusable; it is 'lost' within concrete haunch.

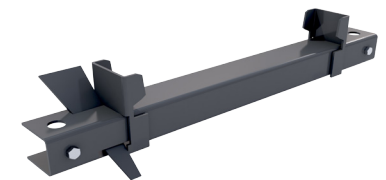

Type 903/904 In-line catch basins

Two part catch basin; bases have 4", 6" and 8" drill-outs for pipe connections. Supplied with plastic trash bucket. Optional riser available for increased depth. Contact ACO for non-polyethylene riser/bases. Available with either galvanized or stainless steel edge rail.

Any channel can be connected to catch basin by removing end/side wall to correct height. Cut-outs guide connection to channels 00, 010, 020, 030 and 040. All cut-outs to receive male channel ends. Blanking end rail supplied to stop concrete ingress during final pour.

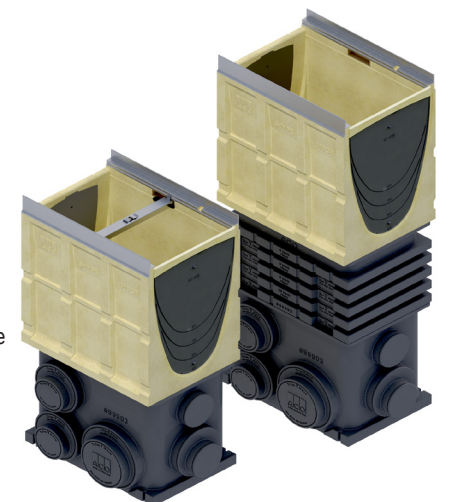

Meter channels

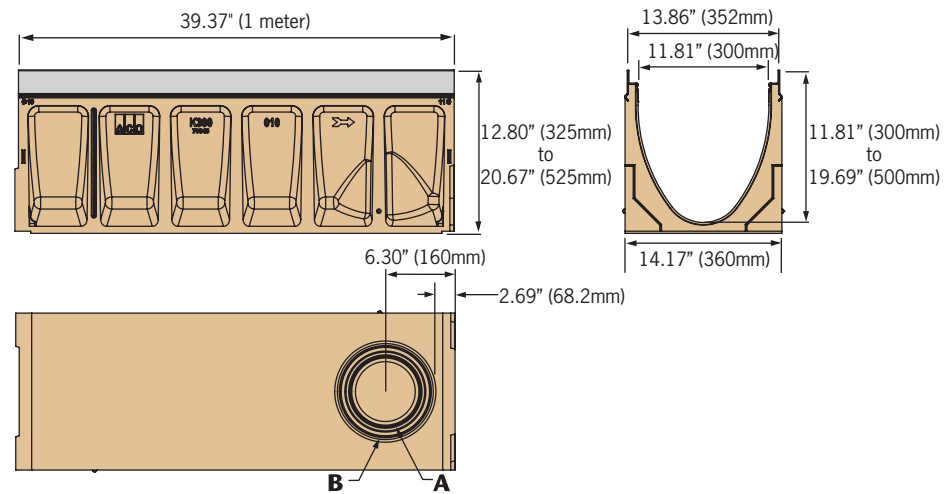

Half meter channels

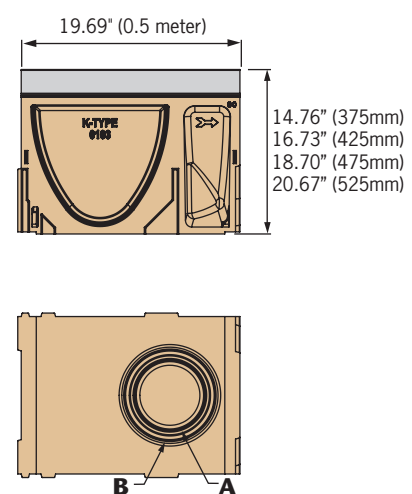

Outlet flow rates

Channels		Invert in.	GPM	CFS
A	K00 - 6" round	11.81"	421	0.94
A	K40 - 6" round	19.69"	544	1.21
B	K00 - 8" round	11.81"	748	1.67
B	K40 - 8" round	19.69"	966	2.15
C	K00 - 6" round	11.81"	364	0.81
C	K40 - 6" round	19.69"	500	1.11
D	K10 - 8" round	13.78"	681	1.52
D	K40 - 8" round	19.69"	863	1.92
E	K20 - 10" round	15.75"	1116	2.49
E	K40 - 10" round	19.69"	1304	2.91

Catch basins		K3-903G/S			K3-904G/S		
Outlet	Size (Sch 40)	Invert in.	GPM	CFS	Invert in.	GPM	CFS
a	4" round	29.80"	287	0.64	41.80"	343	0.77
b	4" round	36.29"	319	0.71	48.29"	370	0.83
c	4" round	28.22"	279	0.62	40.22"	337	0.75
d	6" round	36.29"	707	1.57	48.29"	824	1.84
e	4" round	28.37"	280	0.62	40.37"	337	0.75
f	4" round	34.87"	312	0.70	46.87"	365	0.81
g	6" round	29.15"	626	1.40	41.15"	757	1.69
h	4" round	28.59"	281	0.63	40.59"	338	0.75
i	6" round	36.28"	707	1.57	48.28"	824	1.84
j	4" round	35.72"	316	0.70	47.72"	368	0.82
k	6" round	35.72"	701	1.56	47.72"	819	1.83
l	8" round	36.28"	1237	2.76	48.28"	1449	3.23
m	6" round	34.78"	690	1.54	46.78"	810	1.81
n	4" round	27.65"	276	0.61	39.65"	334	0.74
o	4" round	34.36"	310	0.69	46.36"	363	0.81

Note: These are pipe flow rates at specified outlet, **NOT** channel flow rates. Catch basin flow rates without trash bucket - using trash bucket reduces flow.

Closing/6 in., 8 in. or 10 in. outlet cap

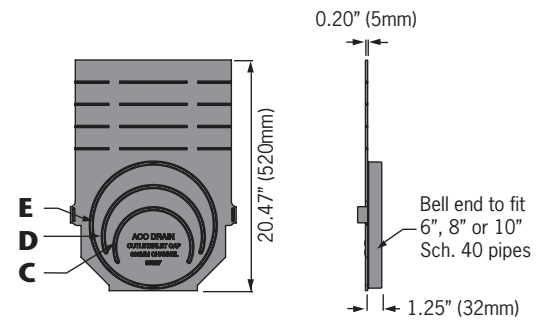

Installation device

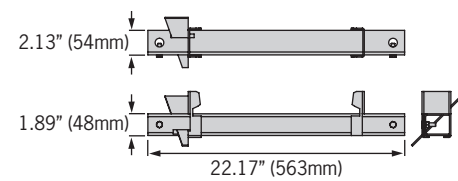

K3-903G/S In-line catch basin

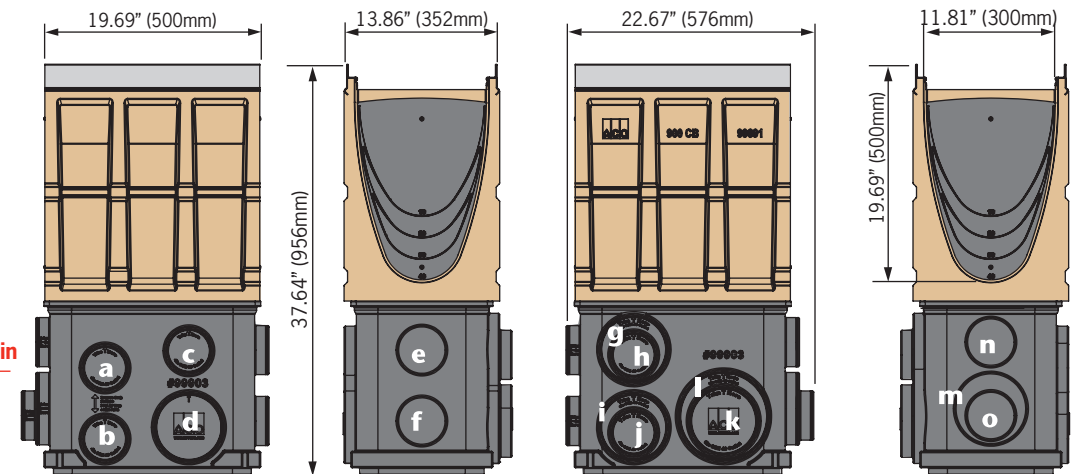

K3-904G/S In-line catch basin

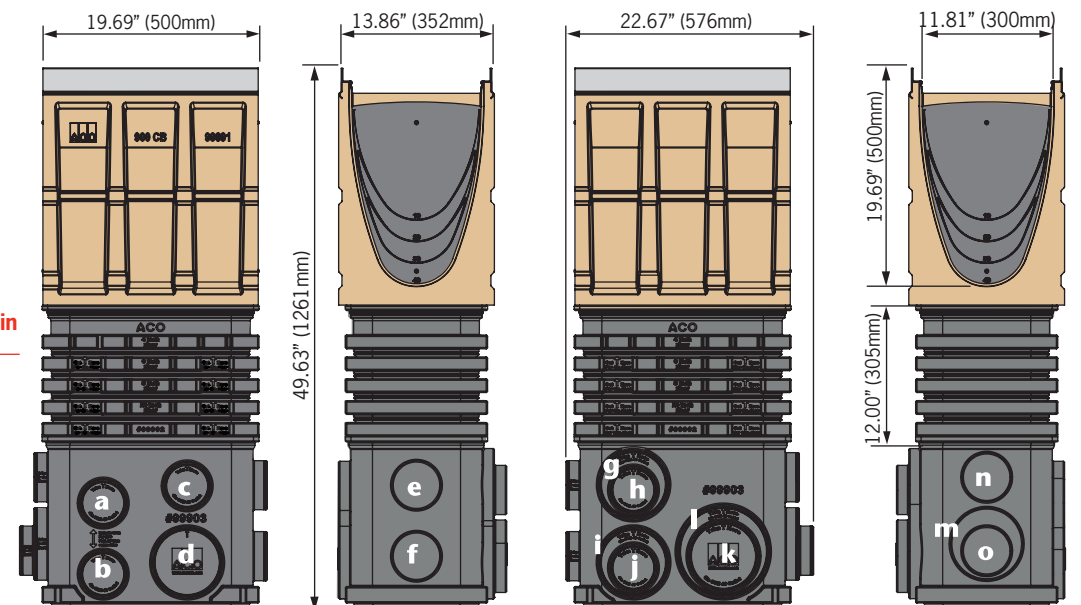

K300/KS300 Parts table

	Part No.		Invert Depth				Overall Depth				Vol	Wgt
	K300	KS300	Inches		mm		Inches		mm		Gal	lbs
			female	male	female	male	female	male	female	male		
K3-00 Constant depth channel - 39.37" (1m) ³	76041	76441	11.81	11.81	300	300	12.80	12.80	325	325	18.01	132.6
K3-1 Sloped channel - 39.37" (1m)	76001	76401	11.81	12.01	300	305	12.80	12.99	325	330	19.58	132.6
K3-2 Sloped channel - 39.37" (1m)	76002	76402	12.01	12.20	305	310	12.99	13.19	330	335	20.01	133.8
K3-3 Sloped channel - 39.37" (1m)	76003	76403	12.20	12.40	310	315	13.19	13.39	335	340	20.44	135.0
K3-4 Sloped channel - 39.37" (1m)	76004	76404	12.40	12.60	315	320	13.39	13.58	340	345	20.86	136.2
K3-5 Sloped channel - 39.37" (1m) ³	76005	76405	12.60	12.80	320	325	13.58	13.78	345	350	21.28	137.4
K3-6 Sloped channel - 39.37" (1m)	76006	76406	12.80	12.99	325	330	13.78	13.98	350	355	21.69	138.6
K3-7 Sloped channel - 39.37" (1m)	76007	76407	12.99	13.19	330	335	13.98	14.17	355	360	22.11	139.8
K3-8 Sloped channel - 39.37" (1m)	76008	76408	13.19	13.39	335	340	14.17	14.37	360	365	22.51	141.0
K3-9 Sloped channel - 39.37" (1m)	76009	76409	13.39	13.58	340	345	14.37	14.57	365	370	22.92	142.2
K3-10 Sloped channel - 39.37" (1m) ³	76010	76410	13.58	13.78	345	350	14.57	14.76	370	375	23.32	143.4
K3-010 Constant depth channel - 39.37" (1m) ³	76043	76443	13.78	13.78	350	350	14.76	14.76	375	375	21.22	143.4
K3-0103 Constant depth channel - 19.69" (0.5m) ³	76044	76444	13.78	13.78	350	350	14.76	14.76	375	375	10.61	75.3
K3-11 Sloped channel - 39.37" (1m)	76011	76411	13.78	13.98	350	355	14.76	14.96	375	380	23.72	144.6
K3-12 Sloped channel - 39.37" (1m)	76012	76412	13.98	14.17	355	360	14.96	15.16	380	385	24.11	145.8
K3-13 Sloped channel - 39.37" (1m)	76013	76413	14.17	14.37	360	365	15.16	15.35	385	390	24.51	147.0
K3-14 Sloped channel - 39.37" (1m)	76014	76414	14.37	14.57	365	370	15.35	15.55	390	395	24.89	148.2
K3-15 Sloped channel - 39.37" (1m) ³	76015	76415	14.57	14.76	370	375	15.55	15.75	395	400	25.27	149.4
K3-16 Sloped channel - 39.37" (1m)	76016	76416	14.76	14.96	375	380	15.75	15.94	400	405	25.68	150.6
K3-17 Sloped channel - 39.37" (1m)	76017	76417	14.96	15.16	380	385	15.94	16.14	405	410	26.06	151.8
K3-18 Sloped channel - 39.37" (1m)	76018	76418	15.16	15.35	385	390	16.14	16.34	410	415	26.44	153.0
K3-19 Sloped channel - 39.37" (1m)	76019	76419	15.35	15.55	390	395	16.34	16.54	415	420	26.83	154.2
K3-20 Sloped channel - 39.37" (1m) ³	76020	76420	15.55	15.75	395	400	16.54	16.73	420	425	27.21	155.4
K3-020 Constant depth channel - 39.37" (1m) ³	76045	76445	15.75	15.75	400	400	16.73	16.73	425	425	24.53	155.4
K3-0203 Constant depth channel - 19.69" (0.5m) ³	76046	76446	15.75	15.75	400	400	16.73	16.73	425	425	12.27	82.3
K3-21 Sloped channel - 39.37" (1m)	76021	76421	15.75	15.94	400	405	16.73	16.93	425	430	27.59	156.7
K3-22 Sloped channel - 39.37" (1m)	76022	76422	15.94	16.14	405	410	16.93	17.13	430	435	27.97	157.9
K3-23 Sloped channel - 39.37" (1m)	76023	76423	16.14	16.34	410	415	17.13	17.32	435	440	28.34	159.1
K3-24 Sloped channel - 39.37" (1m)	76024	76424	16.34	16.54	415	420	17.32	17.52	440	445	28.72	160.3
K3-25 Sloped channel - 39.37" (1m) ³	76025	76425	16.54	16.73	420	425	17.52	17.72	445	450	29.09	161.5
K3-26 Sloped channel - 39.37" (1m)	76026	76426	16.73	16.93	425	430	17.72	17.91	450	455	29.47	162.7
K3-27 Sloped channel - 39.37" (1m)	76027	76427	16.93	17.13	430	435	17.91	18.11	455	460	29.84	163.9
K3-28 Sloped channel - 39.37" (1m)	76028	76428	17.13	17.32	435	440	18.11	18.31	460	465	30.21	165.1
K3-29 Sloped channel - 39.37" (1m)	76029	76429	17.32	17.52	440	445	18.31	18.50	465	470	30.58	166.3
K3-30 Sloped channel - 39.37" (1m) ³	76030	76430	17.52	17.72	445	450	18.50	18.70	470	475	30.95	167.5
K3-030 Constant depth channel - 39.37" (1m) ³	76047	76447	17.72	17.72	450	450	18.70	18.70	475	475	27.87	167.5
K3-0303 Constant depth channel - 19.69" (0.5m) ³	76048	76448	17.72	17.72	450	450	18.70	18.70	475	475	13.94	89.5
K3-31 Sloped channel - 39.37" (1m)	76031	76431	17.72	17.91	450	455	18.70	18.90	475	480	31.32	168.7
K3-32 Sloped channel - 39.37" (1m)	76032	76432	17.91	18.11	455	460	18.90	19.09	480	485	31.69	169.9
K3-33 Sloped channel - 39.37" (1m)	76033	76433	18.11	18.31	460	465	19.09	19.29	485	490	32.06	171.1
K3-34 Sloped channel - 39.37" (1m)	76034	76434	18.31	18.50	465	470	19.29	19.49	490	495	32.42	172.3
K3-35 Sloped channel - 39.37" (1m) ³	76035	76435	18.50	18.70	470	475	19.49	19.69	495	500	32.79	173.5
K3-36 Sloped channel - 39.37" (1m)	76036	76436	18.70	18.90	475	480	19.69	19.88	500	505	33.16	174.7
K3-37 Sloped channel - 39.37" (1m)	76037	76437	18.90	19.09	480	485	19.88	20.08	505	510	33.52	175.9
K3-38 Sloped channel - 39.37" (1m)	76038	76438	19.09	19.29	485	490	20.08	20.28	510	515	33.88	177.1
K3-39 Sloped channel - 39.37" (1m)	76039	76439	19.29	19.49	490	495	20.28	20.47	515	520	34.25	178.3
K3-40 Sloped channel - 39.37" (1m) ³	76040	76440	19.49	19.69	495	500	20.47	20.67	520	525	34.61	179.5
K3-040 Constant depth channel - 39.37" (1m) ³	76049	76449	19.69	19.69	500	500	20.67	20.67	525	525	31.25	179.5
K3-0403 Constant depth channel - 19.69" (0.5m) ³	76050	76450	19.69	19.69	500	500	20.67	20.67	525	525	15.63	97.7
K3 Universal end/6", 8" & 10" inlet/outlet cap	96826	-	19.69	19.69	500	500	20.47	20.47	520	520	-	2.5
Installation device	97479	-	-	-	-	-	-	-	-	-	-	4.9
Grate removal tool	01318	-	-	-	-	-	-	-	-	-	-	0.3
QuickLok™ locking bar	10458	-	-	-	-	-	-	-	-	-	-	0.7

- Notes:**
1. K300 has a galvanized steel edge rail for general use. KS300 has a grade 304 stainless steel edge rail for use where increased aesthetics or corrosion resistance is required.
 2. KlassikDrain is sold as channel only. Choose appropriate grate from pages 52-53.
 3. Preformed 6" & 8" dia. drill-outs cast on underside of certain channels (00, 5, 10, 010, 0103, 15, 20, 020, 0203, 25, 30, 030, 0303, 35, 40, 040, 0403).
 4. Closing/outlet cap can be cut down to suit all channels.
 5. Catch basin details on page 51.

Polymer concrete catch basins

Polymer concrete catch basins are used either as stand alone area drains or more commonly as the outlet to a trench run. They provide the highest hydraulic output and allow easy access to the pipe system for maintenance.

In-line Type 903 and 904 catch basins same width and visually indistinguishable from trench run.

**K3-Type 903
12 in. wide in-line catch basin**

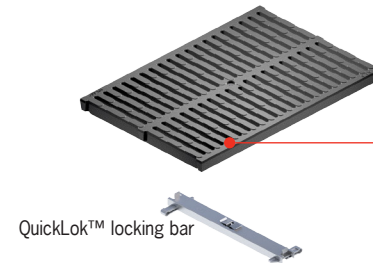

Grates - choice of grates to match/complement channel with DrainLok™ or QuickLok™ boltless locking. See page 52-53. QuickLok™ grates require a removable QuickLok™ locking bar for easy access to trash bucket and pipework.

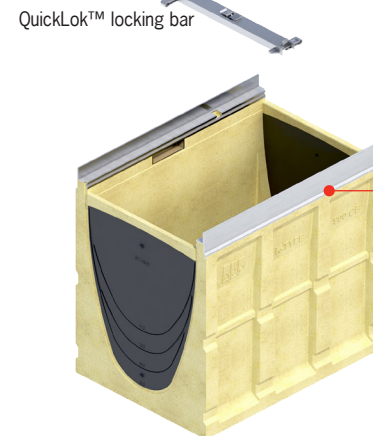

Top section - polymer concrete with integrally cast-in galvanized or stainless steel frame. Guides aid connection of male channel ends at #10, 20, 30 and 40 depths. Other channels can be connected by removing wall to required height. Blanking end rail supplied. See page 155.



Trash bucket - plastic trash bucket designed to collect debris washed from trench run. Supported in catch basin top to avoid creation of a vacuum and reduction in outflow. K3-904 uses deeper bucket with riser.

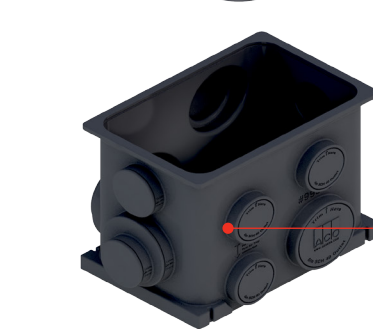

Riser - a plastic riser, supplied with K3-904, designed to provide additional catch basin depth and hydraulic output. Guides enable cutting to size at 2" (50mm) intervals - minimum 2" and maximum 12" height. Additional units can be used (a maximum of 2 is recommended to ensure snake access is maintained and for structural stability). Contact ACO for non-polyethylene riser.

Parts table - K300 Catch basins	Part No.		Volume Gallons*	Weight lbs
	K300	KS300		
K3-903 in-line catch basin - 19.69" (0.5m)	94614	94615	30.4	88.0
K3-904 in-line catch basin - 19.69" (0.5m)	94635	94636	40.2	98.0
Series 600 optional riser	99902		9.8	10.0
Foul air trap	90854		-	1.2

* Volume is up to grate seat and without trash bucket.

**K3-Type 904
12 in. wide in-line catch basin
(with riser)**

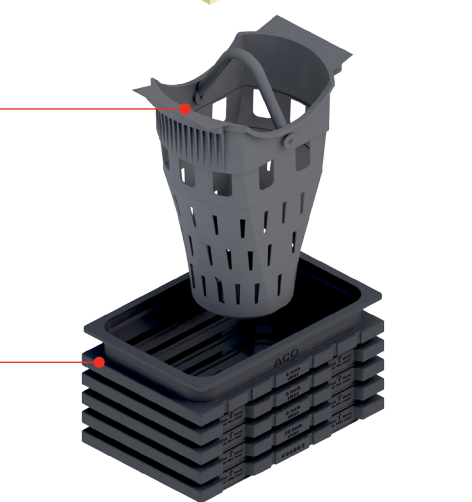
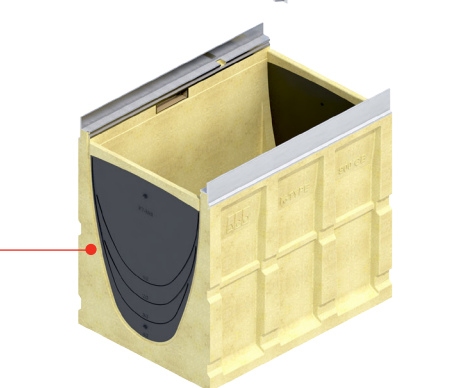
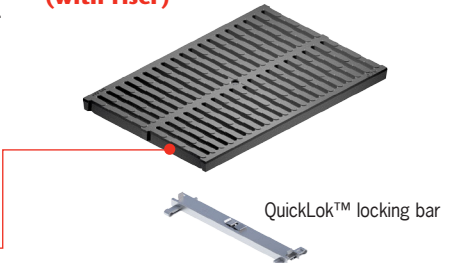

Base - polyethylene bases with wide range of Schedule 40 4", 6" and 8" cut-outs for easy pipe connection. Cut-outs on end and side allow connection of ACO foul air trap. Contact ACO for non-polyethylene bases.

Foul air trap

Available K300/KS300 DrainLok™ grates

Description	Part No.	Length inches (m)	Slot Size inches	Intake area sq. in.	Wgt lbs	DL	Handicap	SAFETY	SAFETY	SAFETY	SAFETY
A Load Class A - 3,500lbs - EN 1433 58psi Pedestrian											
Longitudinal stainless											
Type 847D - stainless	142223	39.37" (1.0m)	0.81 x 0.24	263.2	28.6	DL	✓	✓	✓	✓	51.3
Type 848D - stainless	142224	19.69" (0.5m)		131.6	14.5						
Grade 304 stainless steel											
B Load Class B - 28,000lbs - EN 1433 483psi Light Duty											
Perforated steel											
Type 811D - galvanized	138090	39.37" (1.0m)	0.25 dia.	64.8	30.9	DL	✓	✓	✓	✓	22.6
Type 813D - galvanized	138091	19.69" (0.5m)		31.9	15.0						
Type 865D - stainless*	138092	39.37" (1.0m)	0.25 dia.	64.8	30.9	DL	✓	✓	✓	✓	29.6
Type 866D - stainless*	138093	19.69" (0.5m)		31.9	15.0						
* Grade 304 stainless steel											
C Load Class C - 56,000lbs - EN 1433 967psi Commercial vehicle											
Mesh steel											
Type 805D - galvanized	13819	19.69" (0.5m)	0.63 x 0.87	163.7	29.5	DL	✗	✗	✗	✓	52.1
Type 830D - stainless*	13849	19.69" (0.5m)		163.7	29.5						
* Grade 304 stainless steel											
Slotted iron											
Type 860D - iron	13870	19.69" (0.5m)	0.47 x 2.57 avg	88.1	38.0	DL	✗	✗	✗	✓	31.5
Ductile iron to ASTM A 536-84 - minimum grade 64-45-12											
Longitudinal iron											
Type 876D - iron	99588	19.69" (0.5m)	1.97 x 0.24	64.3	35.0	DL	✓	✓	✓	✓	25.8
Ductile iron to ASTM A 536-84 - minimum grade 64-45-12											
Wave iron											
Type 880D - iron	99581	19.69" (0.5m)	0.27 x 0.9 avg	88.5	48.0	DL	✓	✓	✗	✓	26.6
Ductile iron to ASTM A 536-84 - minimum grade 64-45-12											

DrainLok™ - boltless & barless locking system



1

Fit grate

Position grate onto channel, align anti-shunt detail with recess in rail.



2

Fit grate

Push down or stand on grate until it clicks into position.



3

Grate removal

To remove first grate, insert grate removal tool into slots at end of grate, pull up sharply. Remaining grates can be removed by hand.

Available K300/KS300 QuickLok™ grates

Description	Part No.	Length inches (m)	Slot Size inches	Intake area sq. in.	Wgt lbs	DL	Handicap	SAFETY	SAFETY	SAFETY	SAFETY
C Load Class C - 56,000lbs - EN 1433 967psi Commercial vehicle											
Decorative iron											
Type 881Q - iron	93950	19.69" (0.5m)	0.29 x 0.43 avg	54.6	47.0	QL	✓	✗	✗	✓	38.8
Ductile iron to ASTM A 536-84 - minimum grade 64-45-12											
Mosaic iron											
Type 879Q - iron	93958	19.69" (0.5m)	0.30 x 0.98 avg	47.0	47.3	QL	✓	✗	✗	✓	24.6
Ductile iron to ASTM A 536-84 - minimum grade 64-45-12											
E Load Class E - 135,000lbs - EN 1433 2,321psi Industrial											
Longitudinal iron											
Type 878Q - iron	138130	19.69" (0.5m)	1.0 x 0.31	61.8	52.9	QL	✓	✓	✓	✓	25.8
Ductile iron to ASTM A 536-84 - minimum grade 64-45-12											
Slotted iron											
Type 861Q - iron	10431	19.69" (0.5m)	0.39 x 5.71	97.0	56.0	QL	✗	✗	✗	✓	50.8
Ductile iron to ASTM A 536-84 - minimum grade 64-45-12											

QuickLok™ - boltless locking system



1

Fit locking bar

Locate locking bar in recesses, rotate and use hammer to tap securely into place. Serrated ends grip in recess.



2

Fit locking bar

K300 channels use plastic safety clip to hold in place.



3

Fit grate

To install grate, align QuickLok™ stud directly over locking bar.



4

Fit grate

Push down or stand on grate until it clicks into position.



5

Grate removal

To remove first grate, insert grate removal tool into slots at end of grate, pull up sharply. Remaining grates can be removed by hand.



6

Grate removal

To remove bar, insert screwdriver into hole at end of bar and lever back serrated end; rotate bar free.

- Key**
- Locking mechanism
 - Compliant with Americans with Disabilities Act of 1990 Section 4.5.4 (Page 140)
 - ASME A112.6.3 - 2001 Heel resistant less than 0.31" (8mm) (Page 140)
 - Heel safe equal or less than 0.25" (6.5mm) (Page 140)
 - Bicycle Safe compliant to Australian Standard AS 3996 - 2006 (Page 140)
 - Anti-slip grates - BPN over 24 (Page 140)



MiniKlassik K50/KS50 - 2" wide general purpose system

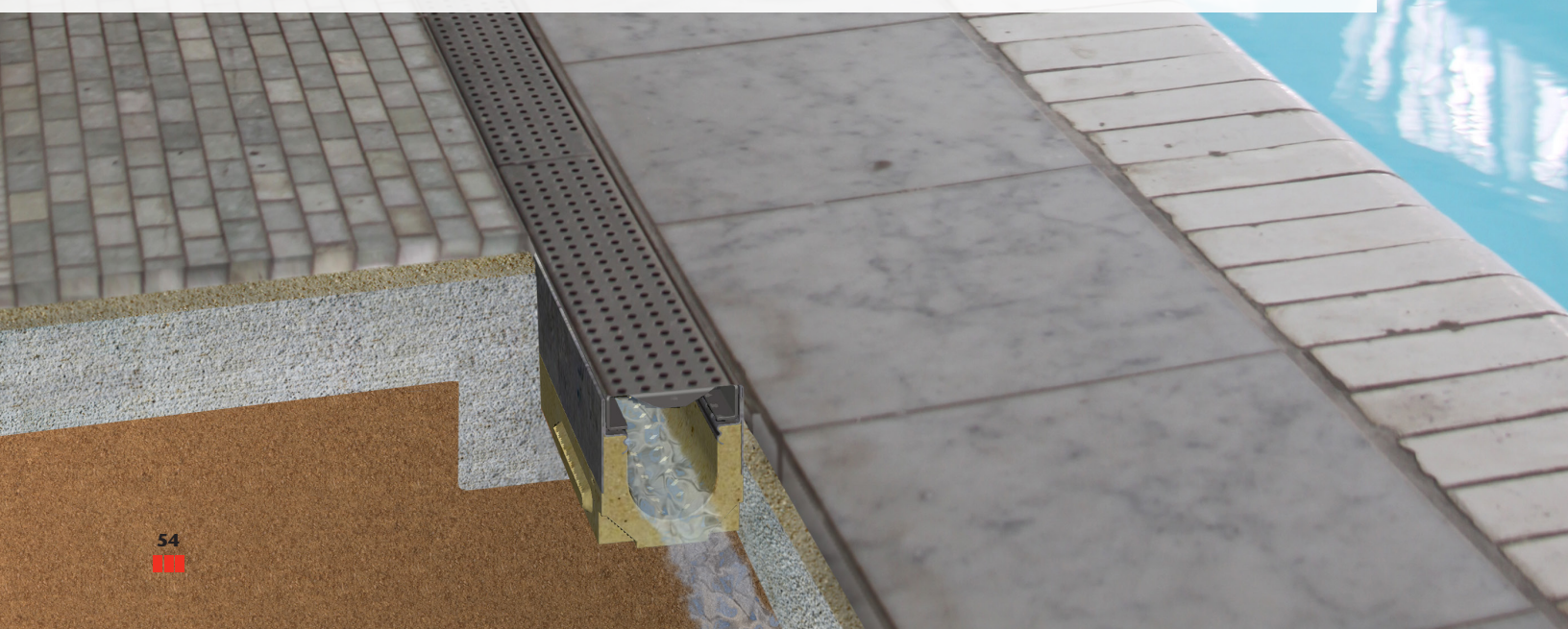

**MiniKlassik K50/
KS50**

Key Dimensions

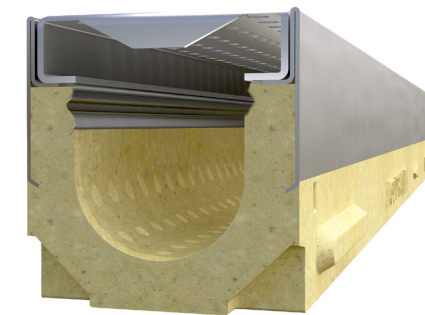
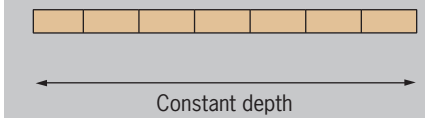
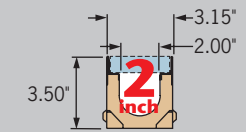

K50 is a 2" internal width system with galvanized steel edge rail for high profile, aesthetic applications where a barrier is required to separate wet and dry areas.

KS50 is the same system, but the edge rail is grade 304 stainless steel. KS50 should be used where increased aesthetics are required, or where increased corrosion resistance is required.

EN 1433 does not cover grates for 2" (50 mm) internal width trench drains, but grates have been load tested in accordance with EN 1433 guidelines. Grates feature patented DrainLok™ boltless locking systems. Loading is determined by grate up to Load Class C (25 ton).



Typical applications

- *Aesthetic areas*
- *Pedestrian plazas*
- *Sidewalks*
- *Paved areas*

Selection criteria



Light to medium duty loads



Product can be used towards LEED & EPA requirements



Resistant to many everyday chemicals. *Check page 139*



Multiple grate options to meet legal requirements



Multiple grate options to meet design requirements



Limited hydraulic capacity



Constant depth channels

ACO DRAIN

MiniKlassik features

Choice of grates - Various materials and styles (including ADA compliant) for applications from Load Class A to Load Class C.

DrainLok™ - Patented, boltless locking system provides quick fitting and removal of grates. Helps reduce installation/maintenance time and cost.

Anti-shunt lugs - Recesses in grate fit around lugs on the edge rail to prevent longitudinal movement.

Integrally cast-in galvanized steel edge rail - Provides additional strength and protects the channel edge from damage. (Stainless steel edge rail also available).

2 in. internal width trench system - Meter (39.37") channels. 'U' shaped bottom improves flow hydraulics.

1.5 in. Sch. 40 drill-out - Allows vertical evacuation at male end of channel at any point along the run.

Interconnecting end profiles - Allow easy and effective joining of channels. Appropriate sealant can be used to create sealed joint.

MiniKlassik K50/ KS50

MiniKlassik Parts table

Description	Part No.		Invert Depth		Overall Depth		Volume	Weight
	K50	KS50	inches	mm	inches	mm	Gallons	lbs
Constant depth channel - 39.37" (1m)	04071	06750	2.90	74	3.50	89	0.64	18.0
Steel closing cap	95395	95403	-	-	3.50	89	-	0.3

Notes:

1. Preformed 1.5" dia. drill-out outlet on underside of channel provides a flow rate of 12.7GPM - 0.03CFS.
2. MiniKlassik does not fit with any ACO catch basin - discharge through vertical outlet only or contact ACO for additional advice.

One meter channel

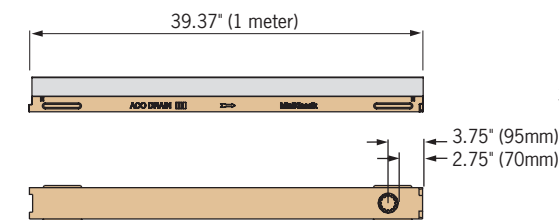

End view

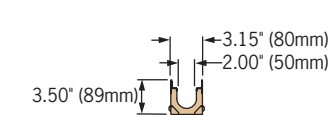

Closing cap

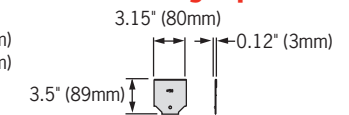

Available K50/KS50 DrainLok™ grates

Description	Part No.	Length inches (m)	Slot Size inches	Intake area sq. in.	Wgt lbs	DL	ADA	HEEL	SAFE	BICYCLE	ANTI-SLIP
A Load Class A - 3,500lbs - EN 1433 70psi Pedestrian											
Perforated steel											
Type 210D - galvanized	138100	39.37" (1.0m)	0.23 dia.	14.5	4.0	DL	✓	✓	✓	✓	23.9
Type 251D - stainless*	138101	39.37" (1.0m)		14.5	4.0						
* Grade 304 stainless steel											
Slotted steel											
Type 220D - galvanized	138102	39.37" (1.0m)	0.38 x 1.35	18.7	4.0	DL	✗	✗	✗	✓	24.4
Type 250D - stainless*	138103	39.37" (1.0m)		18.7	4.0						
* Grade 304 stainless steel											
Mosaic plastic											
Type 200D - black	138104	19.69" (0.5m)	0.3 x 1.2 avg	11.6	0.7	DL	✓	✓	✗	✓	NA
Type 201D - gray	138105	19.69" (0.5m)									
Type 202D - tan	138106	19.69" (0.5m)									
HDPE high density polyethylene											
B Load Class B - 28,000lbs - EN 1433 581psi Light duty											
Longitudinal steel											
Type 247D - stainless	142436	39.37" (1.0m)	1.46 x 0.24	14.9	5.9	DL	✓	✓	✓	✓	31.6
Grade 304 stainless steel											
C Load Class C - 56,000lbs - EN 1433 1,162psi Commercial vehicle											
Longitudinal iron											
Type 276D - iron	138107	19.69" (0.5m)	1.5 x 0.29	17.4	7.3	DL	✓	✓	✗	✓	21.1
Ductile iron to ASTM A 536-84 - minimum grade 64-45-12											

Key

- Locking mechanism
- Compliant with Americans with Disabilities Act of 1990 Section 4.5.4 (Page 140)
- ASME A112.6.3 - 2001 Heel resistant less than 0.31" (8 mm) (Page 140)
- Heel safe equal or less than 0.25" (6.5 mm) (Page 140)
- Bicycle Safe compliant to Australian Standard AS 3996 - 2006 (Page 140)
- Anti-slip grates - BPN over 24 (Page 140)



Brickslot 100/200 - Discreet 4" & 8" slot drainage

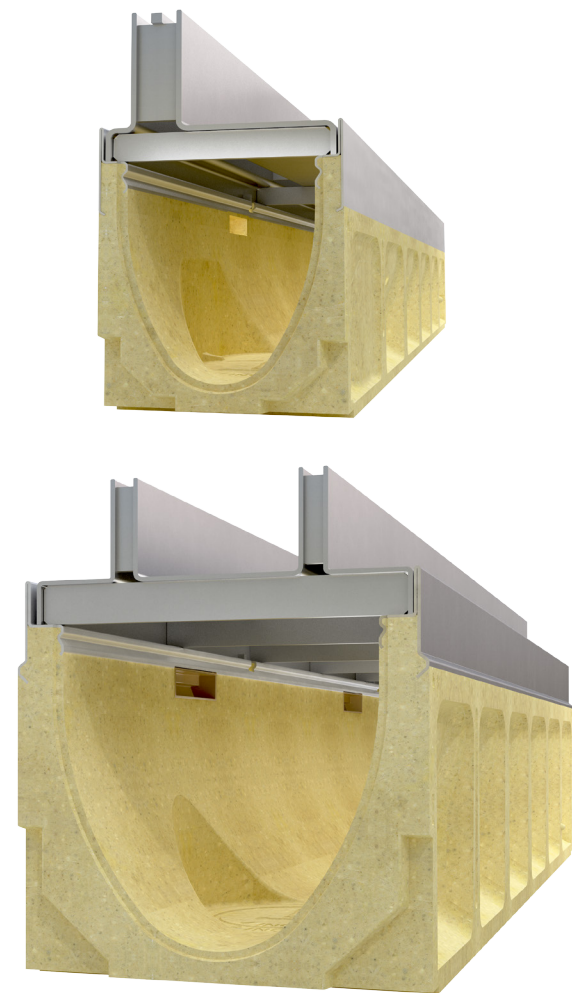

Brickslot 100/200

Key Dimensions

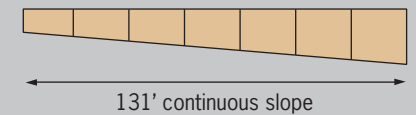
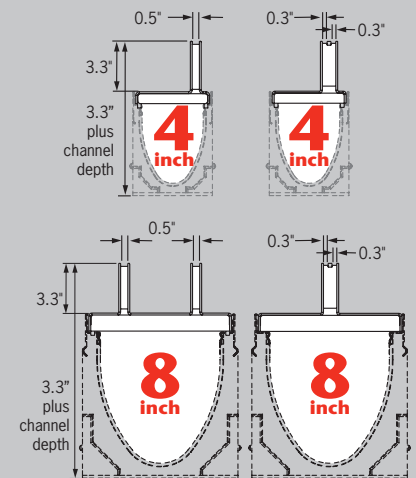

Brickslot is a discreet drainage solution for use with 3 1/8" or less brick or stone pavers. The slot(s) blend in with the paving joints giving an aesthetic solution.

Brickslot 100 offers a single, offset slot, or a twin Heel Resistant slot option. Brickslot 200 offers increased capacity via a double spaced 'Twinslot', or a central twin Heel Resistant slot.

Stainless steel Brickslot is the same system, but is manufactured entirely in grade 304 stainless steel. Stainless steel Brickslot should be used where increased aesthetics are desired, or where increased corrosion resistance is required.

Typical applications

- Aesthetic areas
- Pedestrian plazas
- Sidewalks
- Paved areas

Selection criteria

- Light to medium duty loads
- Product can be used towards LEED & EPA requirements
- Resistant to many everyday chemicals. *Check page 139*
- Multiple grate options to meet legal requirements
- Multiple grate options to meet design requirements
- General everyday or increased hydraulic capacity
- Constant depth and/or sloped depth channels



ACO DRAIN

Brickslot 100 features

½ in. (12mm) slot - Easy to clean smooth slots allow continuous water flow into channel (shown). Offset, heel resistant double 3/8" (8mm) flared slot opening to 1" (25mm) throat for increased drainage capacity (not shown).

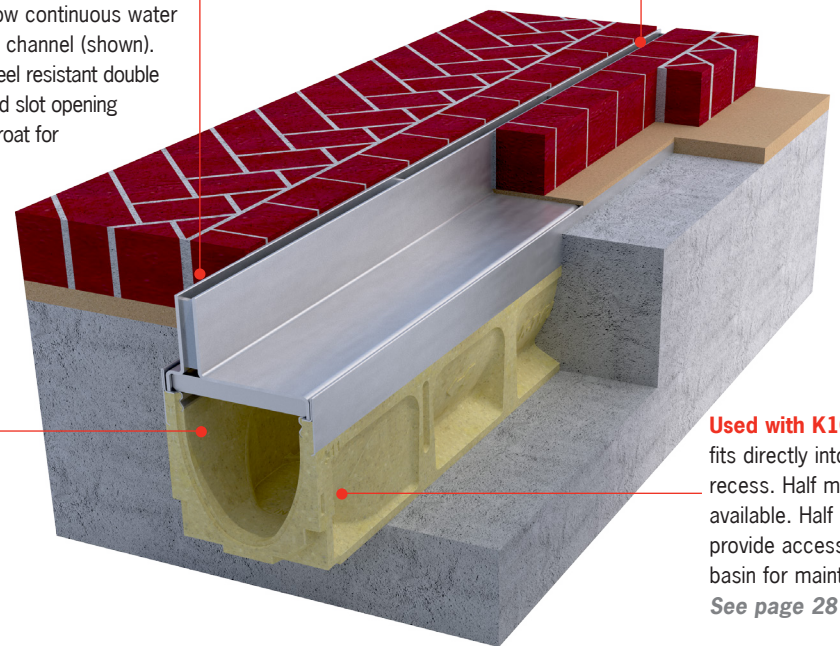

End caps and accessories - Are available from the K100 range. See page 28 for details.

Brick pavers - Fit directly against slot. For light duty pedestrian applications, pavers can be set on sand; for heavier duty projects, pavers should be set on concrete. Maximum paver depth (allowing for 1/8" (3mm) bedding material): 3 1/8" (80mm).

Used with K100 channel - Brickslot fits directly into K100 channel grate recess. Half meter sections are available. Half meter access units provide access to channel or catch basin for maintenance. See page 28 for details.

Brickslot 200 features

Two 6 in. parallel ½ in. (12mm) slots - Easy to clean smooth slots allow continuous water flow into channel (shown).



Central, heel resistant double 3/8" (8mm) flared slot opening to 1" (25mm) throat for increased drainage capacity (not shown).

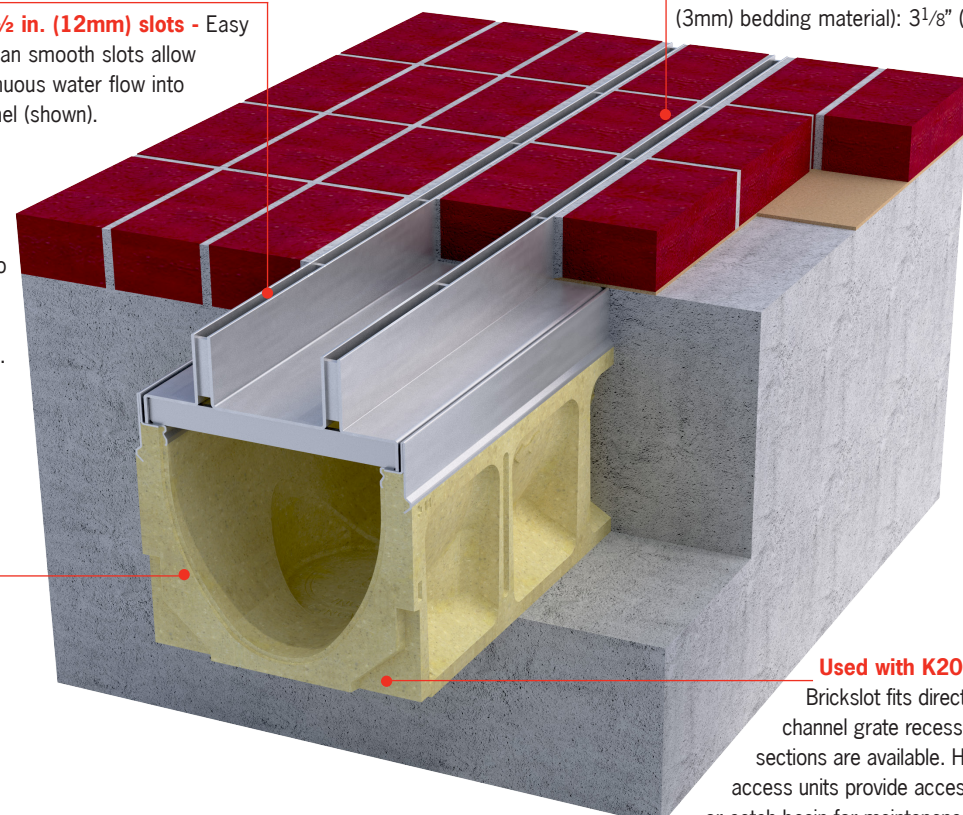

End caps and accessories - Are available from the K200 range. See page 40 for details.

Brick pavers - Fit directly against slot. For light duty pedestrian applications, pavers can be set on sand; for heavier duty projects, pavers should be set on concrete. Maximum paver depth (allowing for 1/8" (3mm) bedding material): 3 1/8" (80mm).

Used with K200 channel - Brickslot fits directly into K200 channel grate recess. Half meter sections are available. Half meter access units provide access to channel or catch basin for maintenance. See page 40 for details.

Brickslot 100/200

Brickslot Parts table

Description	Part No.		Overall Depth		Weight	Wheelchair	Bicycle	Tricycle
	Galv.	Stainless	inches	mm				
Type 441/443 - Brickslot 100 - 39.37" (1m)	138040	138045	4.06	103	17.6	✓	✗	✓
Type 442/444 - Brickslot 100 - 19.69" (0.5m)	138041	138046	4.06	103	9.0	✓	✗	✓
Type 482/484 - Brickslot 100 - access unit - 19.69" (0.5m) ³	138042	138047	4.06	103	16.4	✓	✗	✓
Type 470/472 - Heel Resistant Brickslot 100 - 39.37" (1m)	138050	138055	4.06	103	18.0	✓	✓	✓
Type 471/473 - Heel Resistant Brickslot 100 - 19.69" (0.5m)	138051	138056	4.06	103	9.2	✓	✓	✓
Type 483/485 - Heel Resistant Brickslot 100 access unit - 19.69" (0.5m) ³	138052	138057	4.06	103	16.9	✓	✓	✓
Type 641/643 - Twinslot 200 - 39.37" (1m)	138060	138065	4.45	113	36.3	✓	✗	✓
Type 642/644 - Twinslot 200 - 19.69" (0.5m)	138061	138066	4.45	113	18.7	✓	✗	✓
Type 682/684 - Twinslot 200 access unit - 19.69" (0.5m) ³	138062	138067	4.45	113	32.4	✓	✗	✓
Type 670/673 - Heel Resistant Brickslot 200 - 39.37" (1m)	138070	138075	4.45	113	28.2	✓	✓	✓
Type 672/674 - Heel Resistant Brickslot 200 - 19.69" (0.5m)	138071	138076	4.45	113	14.5	✓	✓	✓
Type 683/685 - Heel Resistant Brickslot 200 access unit - 19.69" (0.5m) ³	138072	138077	4.45	113	29.0	✓	✓	✓
Grate removal tool ⁴	01318		-	-	0.3	-	-	-

Notes:
 1. For K100 channels and K1-900 catch basin information see page 28. For K200 channels and K2-900 catch basin information see page 40.
 2. Brickslot can also be used with SlabDrain HK channels - see page 102.
 3. Access unit can be used on channels or catch basins - for details please refer to separate Spec Info sheets.
 4. Only access cover can be removed once Brickslot has been installed.
 5. For custom slot widths/heights, contact Aquaduct at (800) 543-4764.

Brickslot 100

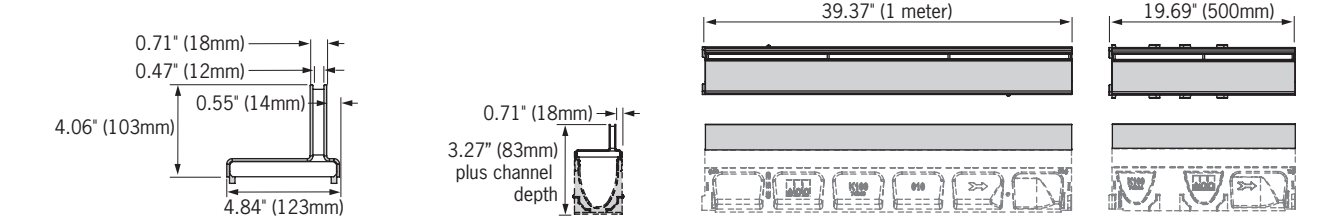

Heel Resistant Brickslot 100

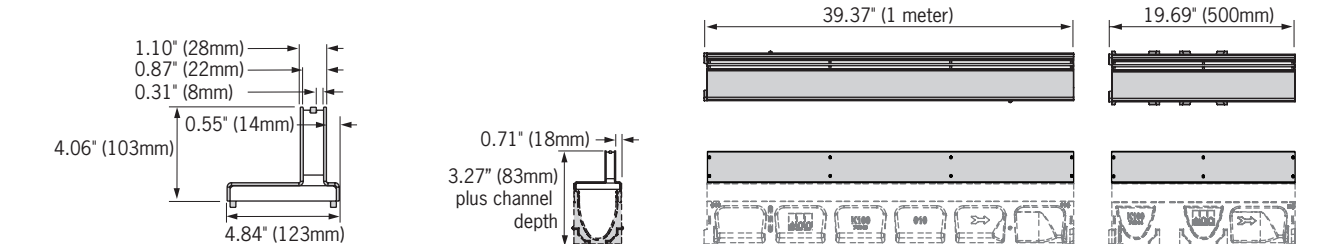

Twinslot 200

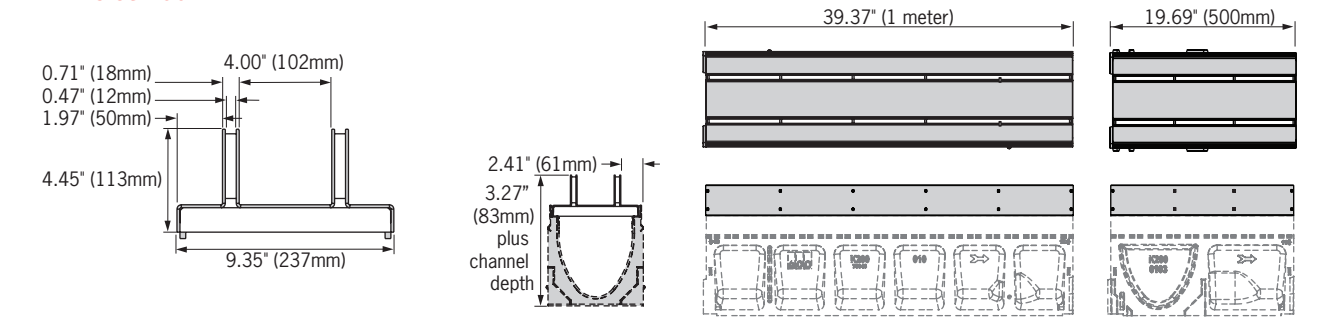

Heel Resistant Brickslot 200

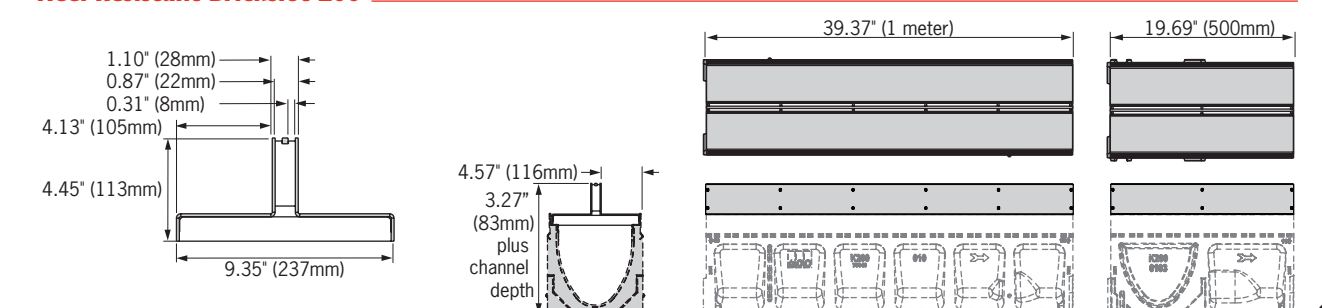



PowerDrain
Heavy duty trench drain

S100K	66
S200K	76
S300K	86

PowerDrain features



Ductile iron grates - Heavy duty ductile iron grates in choice of ADA compliant (Load Class E*) or slotted (Load Class F. (*S100K ADA grates rated to Load Class F).

Ductile iron edge rail - Integrally cast-in rail provides maximum strength and protection for channel body. Shock absorbing widgets, with M10 stainless steel threads, fitted in rail to assist grate fit and aid hanging installation.

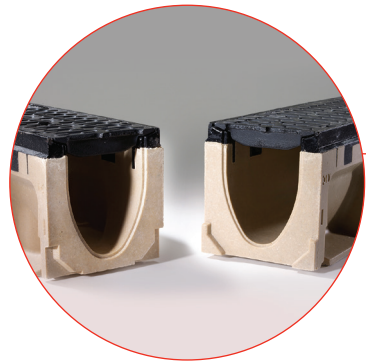

Interconnecting end profiles - Allow easy and effective joining of channels. Appropriate sealant can be used to create sealed joint.

PowerLok™ - A patented, boltless locking system that provides quick fitting and removal of grates. Helps reduce installation/maintenance time and cost.

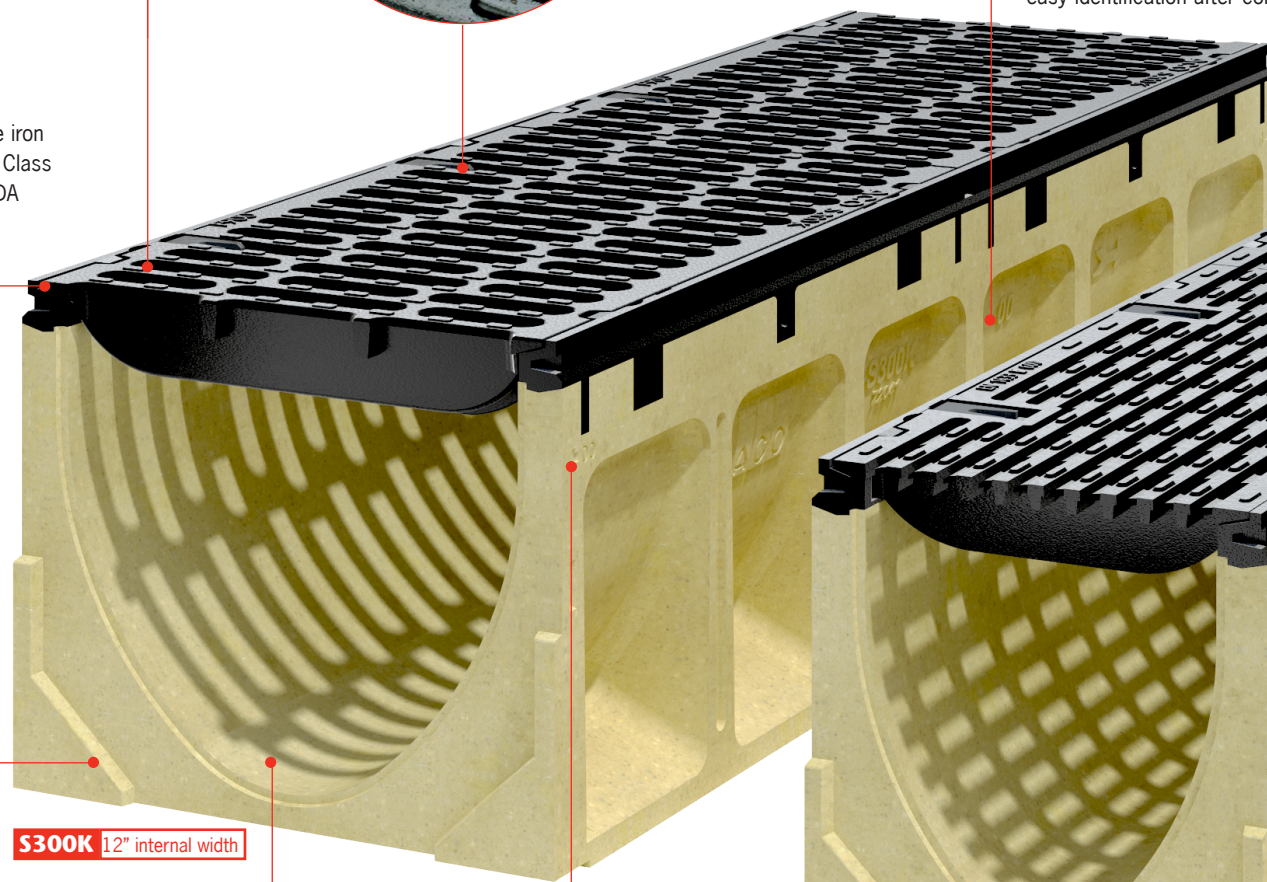
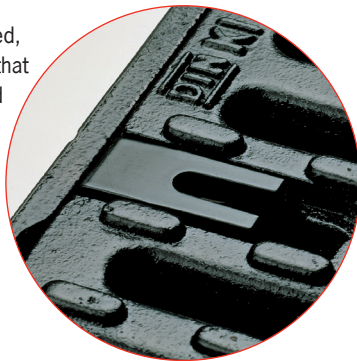

S300K 12" internal width

Polymer concrete - Durable, yet lightweight material made from polyester resin binder reinforced by mineral aggregates and fillers. Provides up to four times the compressive strength of cement concrete. See page 136 for material properties.

System numbering - Each end of channel indicates number of appropriate sloped channel that connects to it.



Channel identification - Channels feature numbering on sidewalls. Numbering in base of channel allows easy identification after concrete encasement.

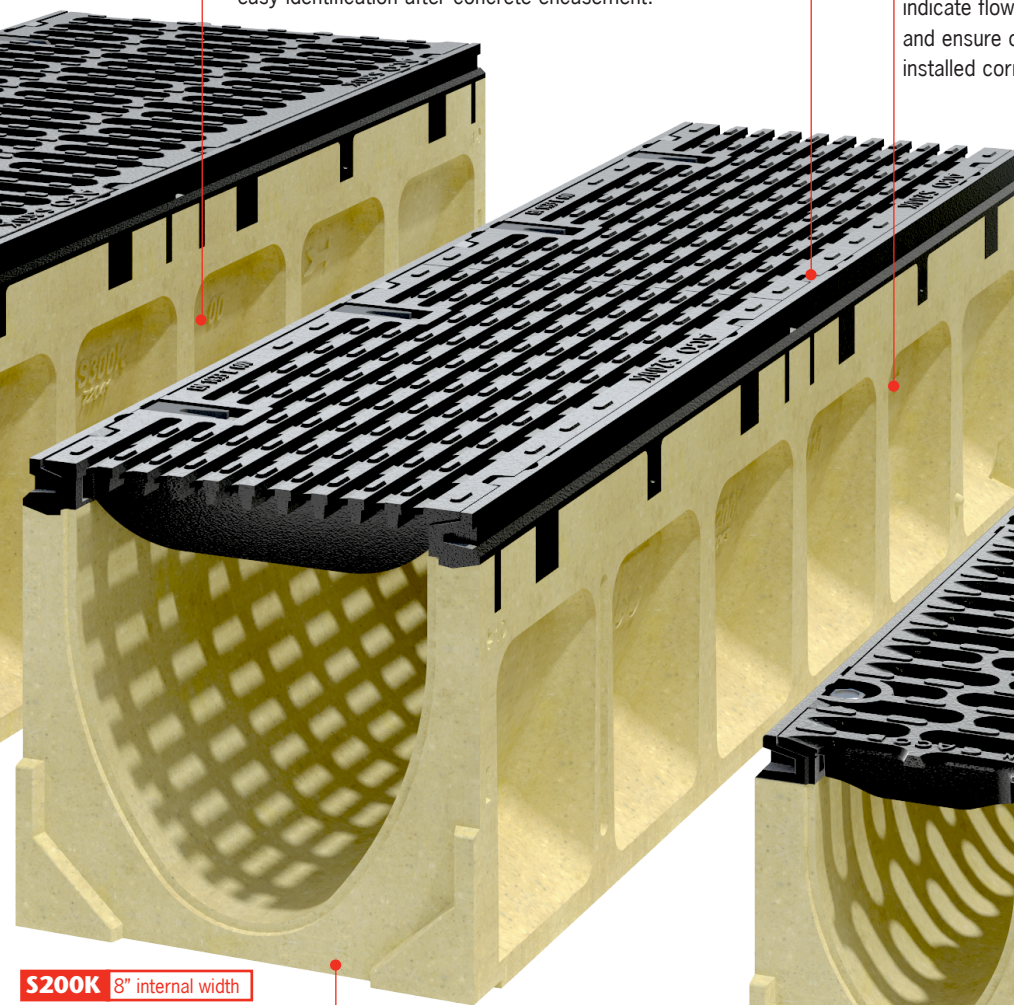

S200K 8" internal width

Knock-outs - Included on all channel units to allow vertical evacuation of the system along the run. See product pages for sizes for each system.



Anti-shunt lugs - Recesses in grate fit around lugs on edge rail to prevent longitudinal movement.

Direction arrows - Cast on side of channel indicate flow direction and ensure channels are installed correctly.

4-Bolt slotted grate - 4-bolt grate option is available on all widths to provide maximum security and stability for super heavy duty applications.

Profiled side walls - Strengthening pillars and frost keys provide channel body strength and mechanical keying to surrounding concrete.

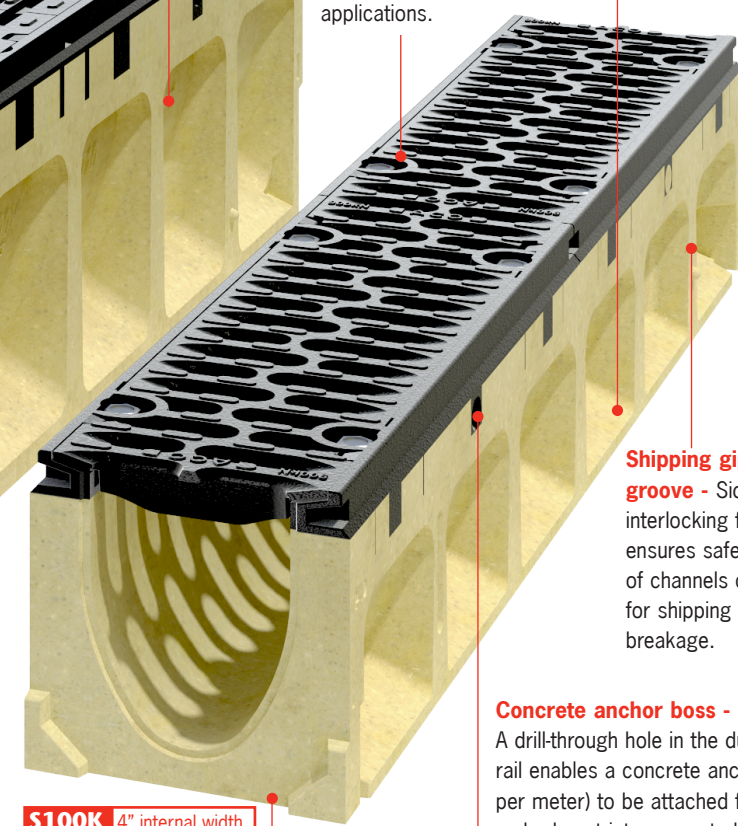

S100K 4" internal width

Shipping gipple/groove - Side interlocking feature ensures safer stacking of channels on pallets for shipping to minimize breakage.

Concrete anchor boss - A drill-through hole in the ductile iron rail enables a concrete anchor (4 per meter) to be attached for extra embedment into concrete haunch.



Sloped (0.5%) channel units - Meter long units provide 131'-3" continuous slope - equates to 1/17" fall per linear foot. Constant depth units can be used to extend run lengths.



S100K - 4" wide heavy duty system

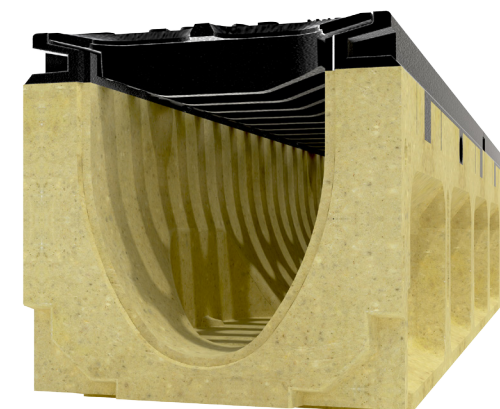

S100K is a 4" wide system with choice of Class F (90 ton) slotted or ADA compliant ductile iron grates featuring PowerLok™ patented boltless locking system. A 4-bolt slotted grate is also available.

PowerDrain S100K

Key Dimensions

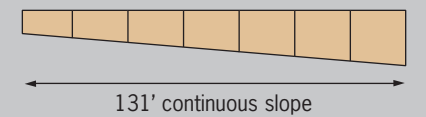
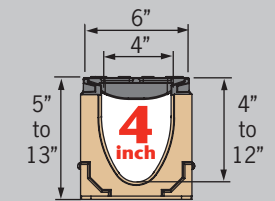

Typical applications

- Airports
- Highways
- Heavy duty industrial areas
- Gas stations
- Docks & ports
- Military bases
- Truck stops

Selection criteria

A B C D E F Light to heavy industrial duty loads

 Product can be used towards LEED & EPA requirements

 Resistant to many everyday chemicals. *Check page 139*

  Multiple grate options to meet legal requirements

  Multiple grate options to meet design requirements

 General everyday hydraulic capacity

  Constant depth and/or sloped depth channels



ACO DRAIN

System layout

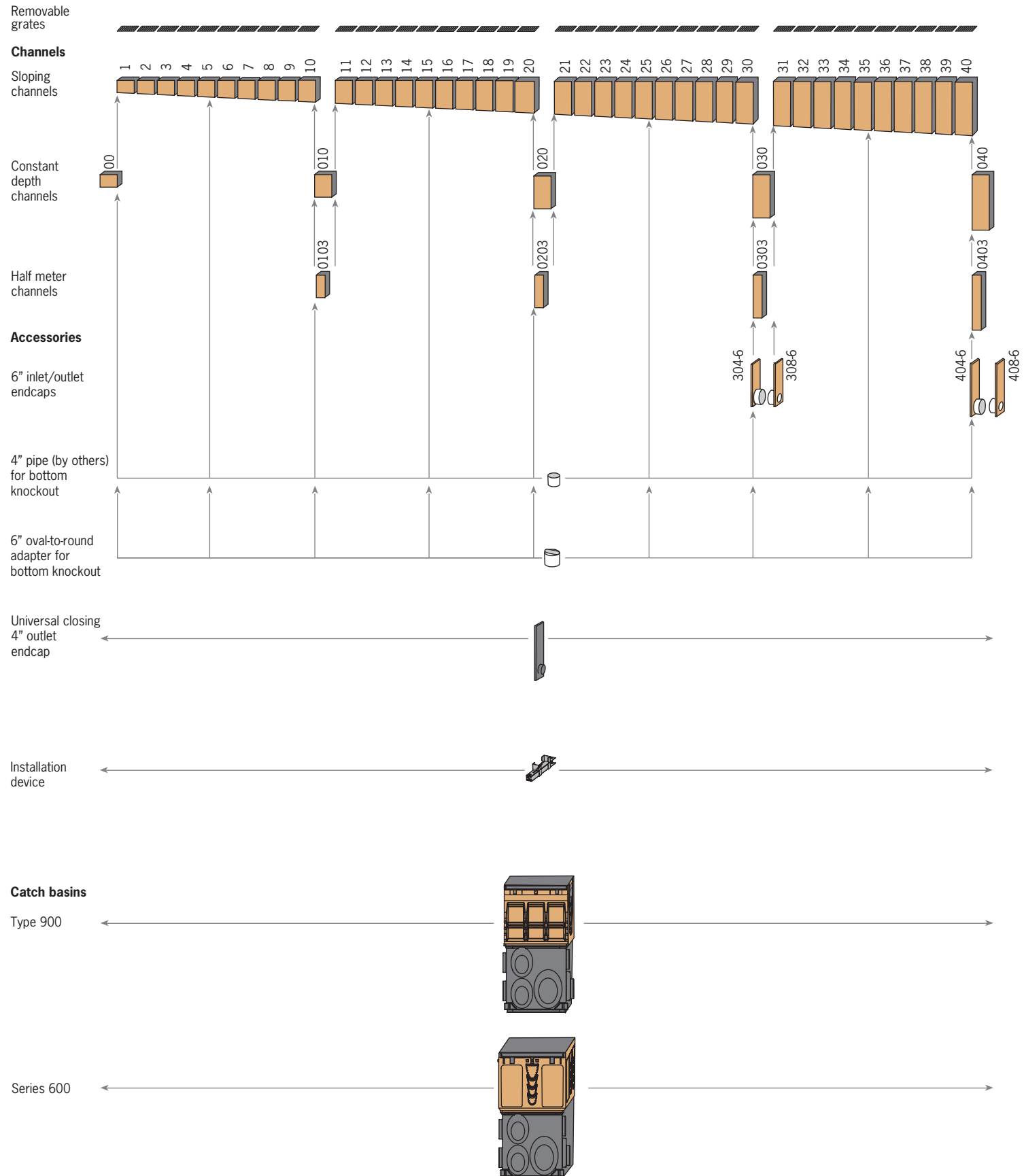

PowerDrain - S100K

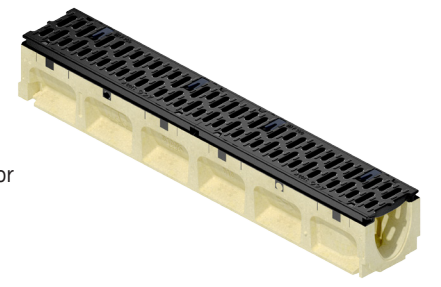

Meter channels - sloping & constant depth

0.5% sloped channels with ductile iron edge rail, in meter lengths and 40 depths to create a 40 meter (131'-2") continuously sloping run.

Constant depth channels are available in 5 depths. Can be used to create non-sloped runs, or inserted in sloped runs to increase length.

Bottom knockouts on all constant depths and 5, 10, 15, 20, 25, 30, 35, 40 channels.



Half meter channels

Constant depth channels with ductile iron edge rail, in 4 depths supplement meter channels. Side knockout and profiling enable side junction to be created. Bottom knockouts on all half meter channels.

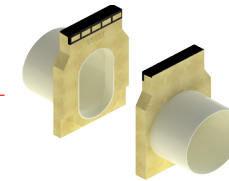

6 in. Sch 40 inlet/outlet caps

6" Schedule 40 plain end polypropylene pipe; oval to round adapter cast into polymer concrete end cap and available in two heights. Solvent weld to coupler.

Note: These end caps cannot be cut to height, and fit only at positions shown in layout diagram.



Closing/4 in. inlet/outlet cap

Fits all channels, manufactured from black ABS to complement edge rail. Guides aid cutting to correct height. Wings clip cap onto end of channel. 4" bell end connection to Schedule 40 pipe. Seal using PVC-ABS cement.

Note: For depth 1-10 channels, ACO recommends removal of unused sections of bell end to ensure adequate pavement material coverage.

Installation device

Fits molded recesses on body of channel. Provides height and joint alignment - a sliding clamp locks the two channels together. Bolt to rebar on either side of channel to hold channels in place during concrete pour. Not reusable; it is 'lost' within concrete haunch.

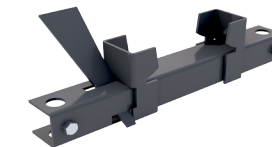

Type 901D In-line catch basin

Two part in-line catch basin with 4", 6" and 8" drill-outs for pipe connection. Supplied with with ductile iron edge rail and plastic trash bucket. Options include an in-line or side foul air trap.



Any channel can be connected into the catch basin by removing the end wall to the correct height with a box cutter. Cut-out guides provided for connection to channels 00, 010, 020, 030 and 040. All cut-outs to receive male channel ends. One blanking end plate supplied with in-line catch basin.

Series 600D catch basin

Two part in-line catch basin; bases have 4", 6" and 8" drill-outs for pipe connections. Supplied with with ductile iron edge rail and plastic trash bucket. Optional riser available for increased depth. Contact ACO for non-polyethylene riser/bases.

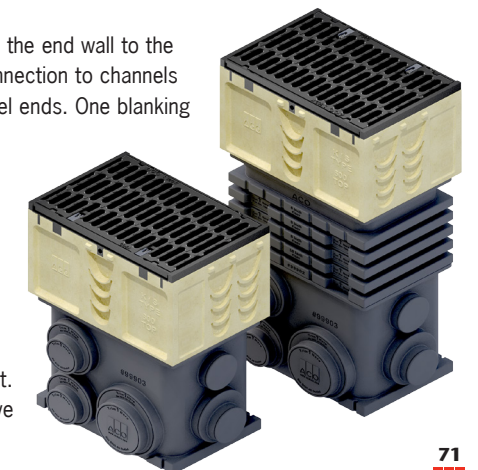

Any channel can be connected to catch basin by removing end/side wall to correct height. Drill-outs guide connection to channels 00, 010, 020, 030 and 040. All cut-outs to receive male channel ends.

Meter channels

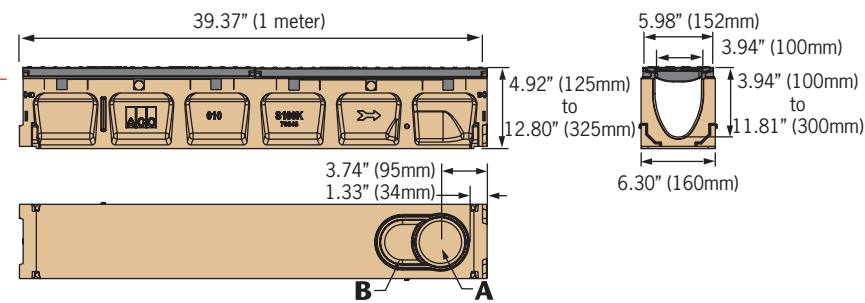

Half meter channels

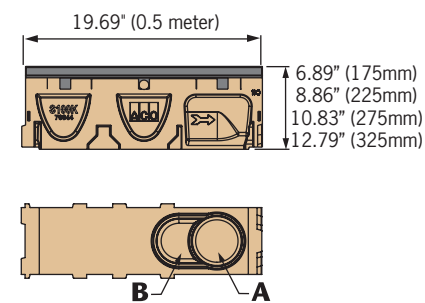

Outlet flow rates

Channels		Invert in.	GPM	CFS
A	SK1-00 - 4" round	3.94"	108	0.24
A	SK1-40 - 4" round	11.81"	187	0.42
B	SK1-00 - 6" oval	3.94"	177	0.39
B	SK1-40 - 6" oval	11.81"	306	0.68
C	SK1-20 - 4" round	7.87"	132	0.29
C	SK1-40 - 4" round	11.81"	171	0.38
D	SK1-30 - 6" oval	9.84"	233	0.52
D	SK1-40 - 6" oval	11.81"	264	0.59

Catch basins	Outlet Size (Sch 40)	SK1-901D			SK1-621D			SK1-631D		
		Invert in.	GPM	CFS	Invert in.	GPM	CFS	Invert in.	GPM	CFS
a	4" round	20.68"	235	0.52	21.29"	239	0.53	33.29"	305	0.68
b	4" round	27.17"	273	0.61	27.79"	276	0.62	39.79"	335	0.75
c	4" round	18.99"	224	0.50	19.72"	229	0.51	31.72"	297	0.66
d	6" round	27.17"	602	1.34	27.79"	610	1.36	39.79"	743	1.66
e	4" round	19.30"	226	0.50	19.84"	230	0.51	31.84"	297	0.66
f	4" round	25.67"	265	0.59	26.34"	269	0.60	38.34"	328	0.73
g	6" round	19.99"	505	1.12	20.62"	514	1.15	32.62"	667	1.49
h	4" round	19.36"	227	0.51	20.07"	231	0.52	32.07"	299	0.67
i	6" round	27.30"	604	1.35	27.76"	609	1.36	39.76"	743	1.65
j	4" round	26.43"	269	0.60	27.19"	273	0.61	39.19"	332	0.74
k	6" round	26.43"	593	1.32	27.19"	602	1.34	39.19"	737	1.64
l	8" round	27.30"	1051	2.34	27.76"	1061	2.36	39.76"	1302	2.90
m	6" round	25.85"	586	1.30	26.28"	591	1.32	38.28"	728	1.62
n	4" round	18.56"	222	0.49	19.15"	225	0.50	31.15"	294	0.65
o	4" round	25.30"	263	0.59	25.86"	266	0.59	37.86"	326	0.73

Note: These are pipe flow rates at specified outlet, NOT channel flow rates. Catch basin flow rates without trash bucket - using trash bucket reduces flow.

6 in. Sch. 40 inlet/outlet caps

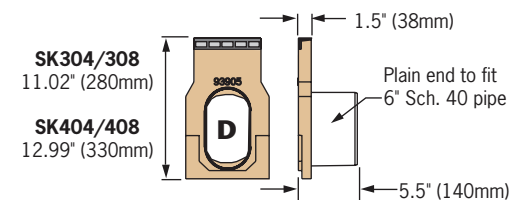

Closing/4 in. inlet/outlet cap

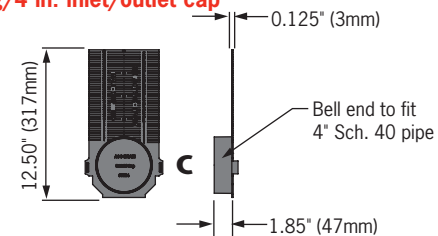

Installation device

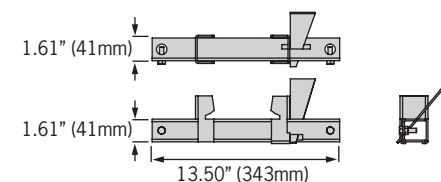

SK1-901D In-line catch basin

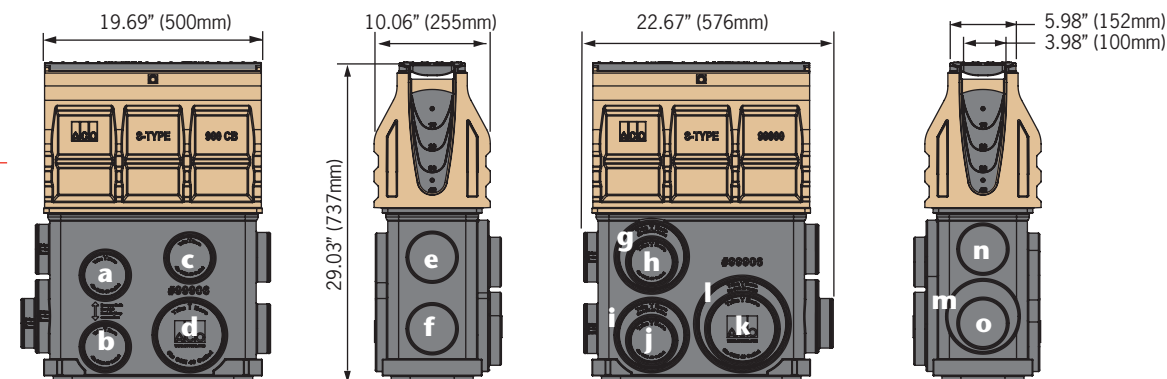

SK1-621D catch basin

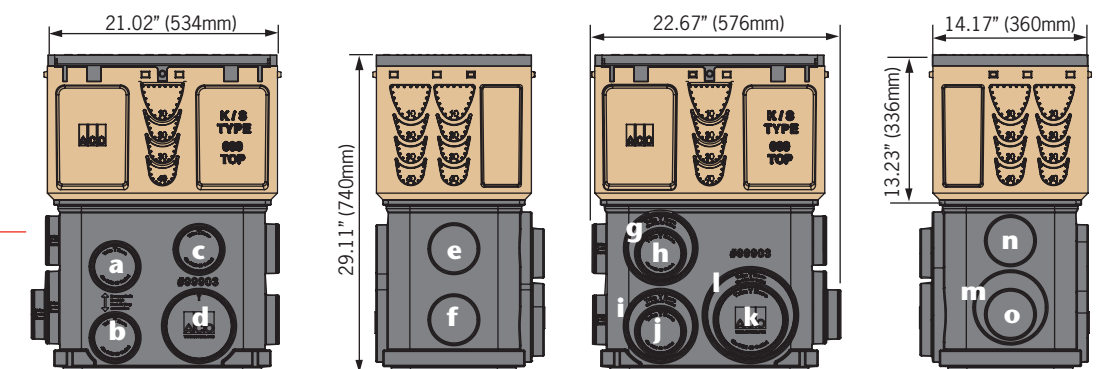

SK1-631D catch basin

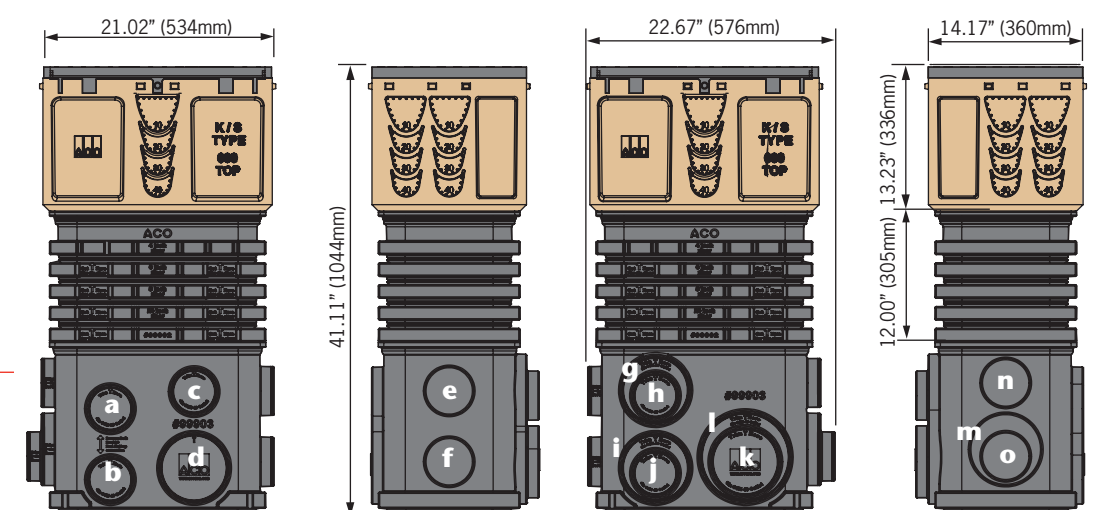

ACO DRAIN

S100K Parts table

	Part No.	Invert Depth				Overall Depth				Vol Gal	Wgt lbs
		Inches		mm		Inches		mm			
		female	male	female	male	female	male	female	male		
SK1-00 Constant depth channel - 39.37" (1m) ²	67041	3.94	3.94	100	100	4.92	4.92	125	125	1.96	48.1
SK1-1 Sloped channel - 39.37" (1m)	67001	3.94	4.13	100	105	4.92	5.12	125	130	1.99	48.1
SK1-2 Sloped channel - 39.37" (1m)	67002	4.13	4.33	105	110	5.12	5.31	130	135	2.04	49.1
SK1-3 Sloped channel - 39.37" (1m)	67003	4.33	4.53	110	115	5.31	5.51	135	140	2.13	50.1
SK1-4 Sloped channel - 39.37" (1m)	67004	4.53	4.72	115	120	5.51	5.71	140	145	2.23	51.1
SK1-5 Sloped channel - 39.37" (1m) ²	67005	4.72	4.92	120	125	5.71	5.91	145	150	2.33	52.1
SK1-6 Sloped channel - 39.37" (1m)	67006	4.92	5.12	125	130	5.91	6.10	150	155	2.43	53.1
SK1-7 Sloped channel - 39.37" (1m)	67007	5.12	5.31	130	135	6.10	6.30	155	160	2.54	54.1
SK1-8 Sloped channel - 39.37" (1m)	67008	5.31	5.51	135	140	6.30	6.50	160	165	2.65	55.1
SK1-9 Sloped channel - 39.37" (1m)	67009	5.51	5.71	140	145	6.50	6.69	165	170	2.75	56.1
SK1-10 Sloped channel - 39.37" (1m) ²	67010	5.71	5.91	145	150	6.69	6.89	170	175	2.86	57.1
SK1-010 Constant depth channel - 39.37" (1m) ²	67043	5.91	5.91	150	150	6.89	6.89	175	175	2.85	57.1
SK1-0103 Constant depth channel - 19.69" (0.5m) ²	67044	5.91	5.91	150	150	6.89	6.89	175	175	1.43	29.4
SK1-11 Sloped channel - 39.37" (1m)	67011	5.91	6.10	150	155	6.89	7.09	175	180	2.97	58.1
SK1-12 Sloped channel - 39.37" (1m)	67012	6.10	6.30	155	160	7.09	7.28	180	185	3.08	59.1
SK1-13 Sloped channel - 39.37" (1m)	67013	6.30	6.50	160	165	7.28	7.48	185	190	3.19	60.1
SK1-14 Sloped channel - 39.37" (1m)	67014	6.50	6.69	165	170	7.48	7.68	190	195	3.30	61.1
SK1-15 Sloped channel - 39.37" (1m) ²	67015	6.69	6.89	170	175	7.68	7.87	195	200	3.42	62.1
SK1-16 Sloped channel - 39.37" (1m)	67016	6.89	7.09	175	180	7.87	8.07	200	205	3.53	63.1
SK1-17 Sloped channel - 39.37" (1m)	67017	7.09	7.28	180	185	8.07	8.27	205	210	3.64	64.1
SK1-18 Sloped channel - 39.37" (1m)	67018	7.28	7.48	185	190	8.27	8.46	210	215	3.75	65.1
SK1-19 Sloped channel - 39.37" (1m)	67019	7.48	7.68	190	195	8.46	8.66	215	220	3.86	66.1
SK1-20 Sloped channel - 39.37" (1m) ²	67020	7.68	7.87	195	200	8.66	8.86	220	225	3.98	67.1
SK1-020 Constant depth channel - 39.37" (1m) ²	67045	7.87	7.87	200	200	8.86	8.86	225	225	3.97	67.1
SK1-0203 Constant depth channel - 19.69" (0.5m) ²	67046	7.87	7.87	200	200	8.86	8.86	225	225	1.98	33.9
SK1-21 Sloped channel - 39.37" (1m)	67021	7.87	8.07	200	205	8.86	9.06	225	230	4.09	68.1
SK1-22 Sloped channel - 39.37" (1m)	67022	8.07	8.27	205	210	9.06	9.25	230	235	4.20	69.1
SK1-23 Sloped channel - 39.37" (1m)	67023	8.27	8.46	210	215	9.25	9.45	235	240	4.32	70.0
SK1-24 Sloped channel - 39.37" (1m)	67024	8.46	8.66	215	220	9.45	9.65	240	245	4.42	71.0
SK1-25 Sloped channel - 39.37" (1m) ²	67025	8.66	8.86	220	225	9.65	9.84	245	250	4.54	72.0
SK1-26 Sloped channel - 39.37" (1m)	67026	8.86	9.06	225	230	9.84	10.04	250	255	4.66	73.0
SK1-27 Sloped channel - 39.37" (1m)	67027	9.06	9.25	230	235	10.04	10.24	255	260	4.78	74.0
SK1-28 Sloped channel - 39.37" (1m)	67028	9.25	9.45	235	240	10.24	10.43	260	265	4.89	75.0
SK1-29 Sloped channel - 39.37" (1m)	67029	9.45	9.65	240	245	10.43	10.63	265	270	5.00	76.0
SK1-30 Sloped channel - 39.37" (1m) ²	67030	9.65	9.84	245	250	10.63	10.83	270	275	5.11	77.0
SK1-030 Constant depth channel - 39.37" (1m) ²	67047	9.84	9.84	250	250	10.83	10.83	275	275	5.10	77.0
SK1-0303 Constant depth channel - 19.69" (0.5m) ²	67048	9.84	9.84	250	250	10.83	10.83	275	275	2.55	38.4
SK1-31 Sloped channel - 39.37" (1m)	67031	9.84	10.04	250	255	10.83	11.02	275	280	5.23	78.0
SK1-32 Sloped channel - 39.37" (1m)	67032	10.04	10.24	255	260	11.02	11.22	280	285	5.34	79.0
SK1-33 Sloped channel - 39.37" (1m)	67033	10.24	10.43	260	265	11.22	11.42	285	290	5.45	80.0
SK1-34 Sloped channel - 39.37" (1m)	67034	10.43	10.63	265	270	11.42	11.61	290	295	5.56	81.0
SK1-35 Sloped channel - 39.37" (1m) ²	67035	10.63	10.83	270	275	11.61	11.81	295	300	5.68	82.0
SK1-36 Sloped channel - 39.37" (1m)	67036	10.83	11.02	275	280	11.81	12.01	300	305	5.79	83.0
SK1-37 Sloped channel - 39.37" (1m)	67037	11.02	11.22	280	285	12.01	12.20	305	310	5.91	84.0
SK1-38 Sloped channel - 39.37" (1m)	67038	11.22	11.42	285	290	12.20	12.40	310	315	6.02	85.0
SK1-39 Sloped channel - 39.37" (1m)	67039	11.42	11.61	290	295	12.40	12.60	315	320	6.13	86.0
SK1-40 Sloped channel - 39.37" (1m) ²	67040	11.61	11.81	295	300	12.60	12.8	320	325	6.25	87.0
SK1-040 Constant depth channel - 39.37" (1m) ²	67049	11.81	11.81	300	300	12.80	12.80	325	325	6.24	87.0
SK1-0403 Constant depth channel - 19.69" (0.5m) ²	67050	11.81	11.81	300	300	12.80	12.80	325	325	3.12	43.0
SK1-304-6" inlet cap	96861	9.84	9.84	250	250	10.83	10.83	275	275	-	6.2
SK1-308-6" outlet cap	96862	9.84	9.84	250	250	10.83	10.83	275	275	-	6.0
SK1-404-6" inlet cap	96863	11.81	11.81	300	300	12.80	12.80	325	325	-	7.2
SK1-408-6" outlet cap	96864	11.81	11.81	300	300	12.80	12.80	325	325	-	7.0
Universal end/4" inlet outlet cap	96824	11.81	11.81	300	300	12.6	12.6	320	320	-	0.4
Debris strainer for 4" bottom knockout	93488	-	-	-	-	-	-	-	-	-	0.2
4" oval to 6" round outlet adaptor	95140	-	-	-	-	-	-	-	-	-	1.1
Installation device	97477	-	-	-	-	-	-	-	-	-	2.8
Grate removal tool	01318	-	-	-	-	-	-	-	-	-	0.3

- Notes:**
1. PowerDrain is sold as channel only. Choose appropriate grate from page 74.
 2. Preformed 4" dia. & 6" oval drill-outs cast on underside of certain channels (00, 5, 10, 010, 0103, 15, 20, 020, 0203, 25, 30, 030, 0303, 35, 40, 040, 0403).
 3. Closing/outlet cap can be cut down to suit all channels.
 4. Catch basin details on page 73.
 5. Debris strainer details for 4" dia. outlet on page 103.

PowerDrain S100K

Polymer concrete catch basins

Polymer concrete catch basins are used either as stand alone area drains or more commonly as the outlet to a trench run. They provide the highest hydraulic output and allow easy access to pipe system for maintenance.

Type 901D provides an in-line catch basin (same width and visually indistinguishable from trench run) and the Series 600D is 12" wide and provides greater hydraulic output.

SK1-Type 901D
4 in. wide In-line catch basin

SK1-Series 600D
12 in. wide catch basin

Series 600 grates - choice of Class F slotted or Class E longitudinal ADA compliant ductile iron grates with PowerLok™ boltless locking or Class F slotted ductile iron 4-bolt grate. *See page 94.*

Type 900 grates - choice of Class F slotted or ADA compliant ductile iron grates with PowerLok™ boltless locking or slotted ductile iron 4-bolt grate. *See page 74.*

Top section - polymer concrete with integrally cast-in ductile iron frame. Guides aid connection of male channel ends at #10, 20, 30 and 40 depths. Other channels can be connected by removing wall to required height. Blanking end rail supplied with SK1-901D. *See page 155.*

Trash bucket - plastic trash bucket designed to collect debris washed from trench run. Supported in catch basin top to avoid creation of a vacuum and reduction in outflow. SK1-631D uses deeper bucket with riser.

Riser - a plastic riser, supplied with SK1-631D, designed to provide additional catch basin depth and hydraulic output. Guides enable cutting to size at 2" (50mm) intervals - minimum 2" and maximum 12" height. Additional units can be used (a maximum of 2 is recommended to ensure snake access is maintained and for structural stability). Contact ACO for non-polyethylene riser.

Base - polyethylene bases with wide range of Schedule 40 4", 6" and 8" cut-outs for easy pipe connection. Cut-outs on end and side allow connection of ACO foul air trap. Contact ACO for non-polyethylene bases.

Parts table - S100K Catch basins	Part No.	Volume Gallons*	Weight lbs
SK1-901D in-line catch basin - 19.69" (0.5m)	67051	12.5	86.0
SK1-621D catch basin - 19.69" (0.5m)	67053	24.9	75.7
SK1-631D catch basin - 19.69" (0.5m)	67054	34.7	85.7
Series 600 optional riser	99902	9.8	10.0
Foul air trap - fits both Type 901D & 600 basins	90854	-	1.2

* Volume is up to grate seat and without trash bucket.

ACO DRAIN

Available S100K grates

Description	Part No.	Length inches (m)	Slot Size inches	Intake area sq. in.	Wgt lbs	PL	✓	✗	✓	28.1
F Load Class F - 200,000lbs - EN1433 4,177psi Heavy Duty										
Longitudinal iron										
Iron	96096	19.69" (0.5m)	1.36 x 0.45	25.2	13.6	PL	✓	✗	✓	28.1
Ductile iron to ASTM A 536-84 - minimum grade 65-45-12										
Slotted iron										
Iron	96082	19.69" (0.5m)	0.43 x 1.98 avg.	25.7	12.3	PL	✗	✗	✓	35.6
Ductile iron to ASTM A 536-84 - minimum grade 65-45-12										
4-bolt iron										
Iron*	99590	19.69" (0.5m)	0.71 x 1.81 avg.	36.0	10.8	Bolt	✗	✗	✓	35.6
Ductile iron to ASTM A 536-84 - minimum grade 65-45-12. * Supplied with bolts.										

Key

- Locking mechanism
- Compliant with Americans with Disabilities Act of 1990 Section 4.5.4 (Page 140)
- ASME A112.6.3 - 2001 Heel resistant less than 0.31" (8mm) (Page 140)
- Bicycle Safe compliant to Australian Standard AS 3996 - 2006 (Page 140)
- Anti-slip grates - BPN over 24 (Page 140)

Choosing S100K grates

There are three available grate styles to fit the S100K heavy duty channel body.

The conventional slotted grate, with PowerLok™, gives an excellent all-around heavy duty solution with the ease of the PowerLok™ locking/unlocking mechanism. Ideal for use where regular removal of the grate for maintenance is required.

The ADA compliant, longitudinal slotted grate, with PowerLok™, gives the ideal solution to a heavy duty location where some pedestrian access may be required.

Although easy locking and grate removal is important for maintenance, some specific applications require a 4-bolt solution. The four threaded stainless steel inserts in the S100K channel body allow a 4-bolt grate to be bolted into the channel for ultimate stiffness and security. Tamper resistant bolts can also be used.



PowerDrain S100K

PowerLok™ - boltless locking system



1

Fit grate

To lock, position side of grate into lugs on rail, place hook part of tool into 'V' and push towards rail.



2

Grate removal

To open PowerLok™, insert tool between rail and PowerLok™ device.



3

Grate removal

Rotate tool 90°, PowerLok™ device should push away from rail.

PowerLok™ - safety clip

For areas of extra security or safety concerns, an optional safety clip is available that provides a visual alert if the PowerLok™ devices are left open. The clip push fits next to the PowerLok™ device and sits level with the grate when the grate is locked. The clip cannot be fitted if the PowerLok™ is open. If all grates are engaged, a run of red dots is visible.

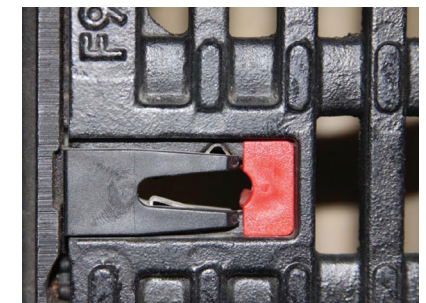

4-Bolt grates



1

Fit grate

Position grate onto channel, align holes in grate with matching holes in edge rail.



2

Fit grate

Using wrench or socket set to tighten. If using a torque wrench, do not set to more than 15 ft. lbs.



3

Grate removal

To remove grates, use wrench or socket set. Carefully store bolts for refitting of grates.

Grate accessories

	Part No.	Weight lbs
PowerLok safety clip (red)	10443	0.1
Replacement bolt for 4-bolt grate	95526	0.1
Tamper resistant bolt for 4-bolt grate	138127	0.1
Tamper resistant bolt drive	138128	0.1



Requires tamper resistant drive bit



S200K - 8" wide heavy duty system

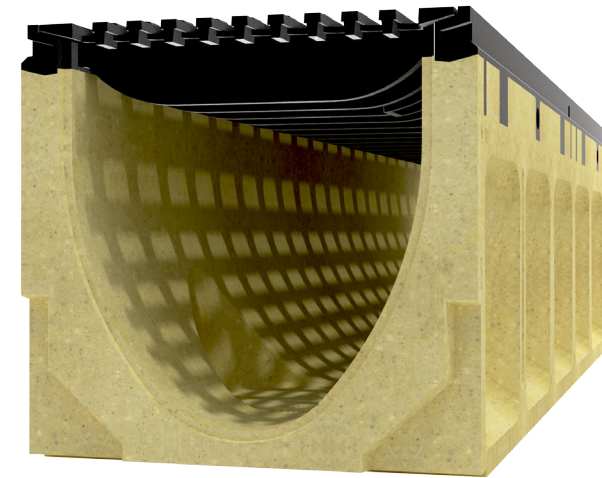

PowerDrain S200K

Key Dimensions

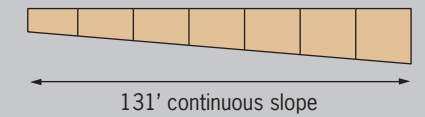
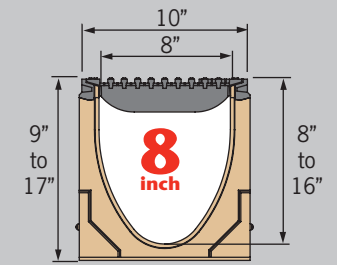









S200K is an 8" wide system with choice of Class F (90 ton) slotted or Class E (60 ton) ADA compliant ductile iron grates featuring the PowerLok™ patented boltless locking system. A 4-bolt slotted grate is also available.

Typical applications

- Airports
- Highways
- Heavy duty industrial areas
- Gas stations
- Docks & ports
- Military bases
- Truck stops

Selection criteria

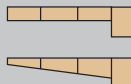
- A B C D E F** Light to heavy industrial duty loads 
-  Product can be used towards LEED & EPA requirements
-  Resistant to many everyday chemicals. *Check page 139*
-   Multiple grate options to meet legal requirements
-   Multiple grate options to meet design requirements
-  Increased hydraulic capacity
-  Constant depth and/or sloped depth channels



ACO DRAIN

System layout

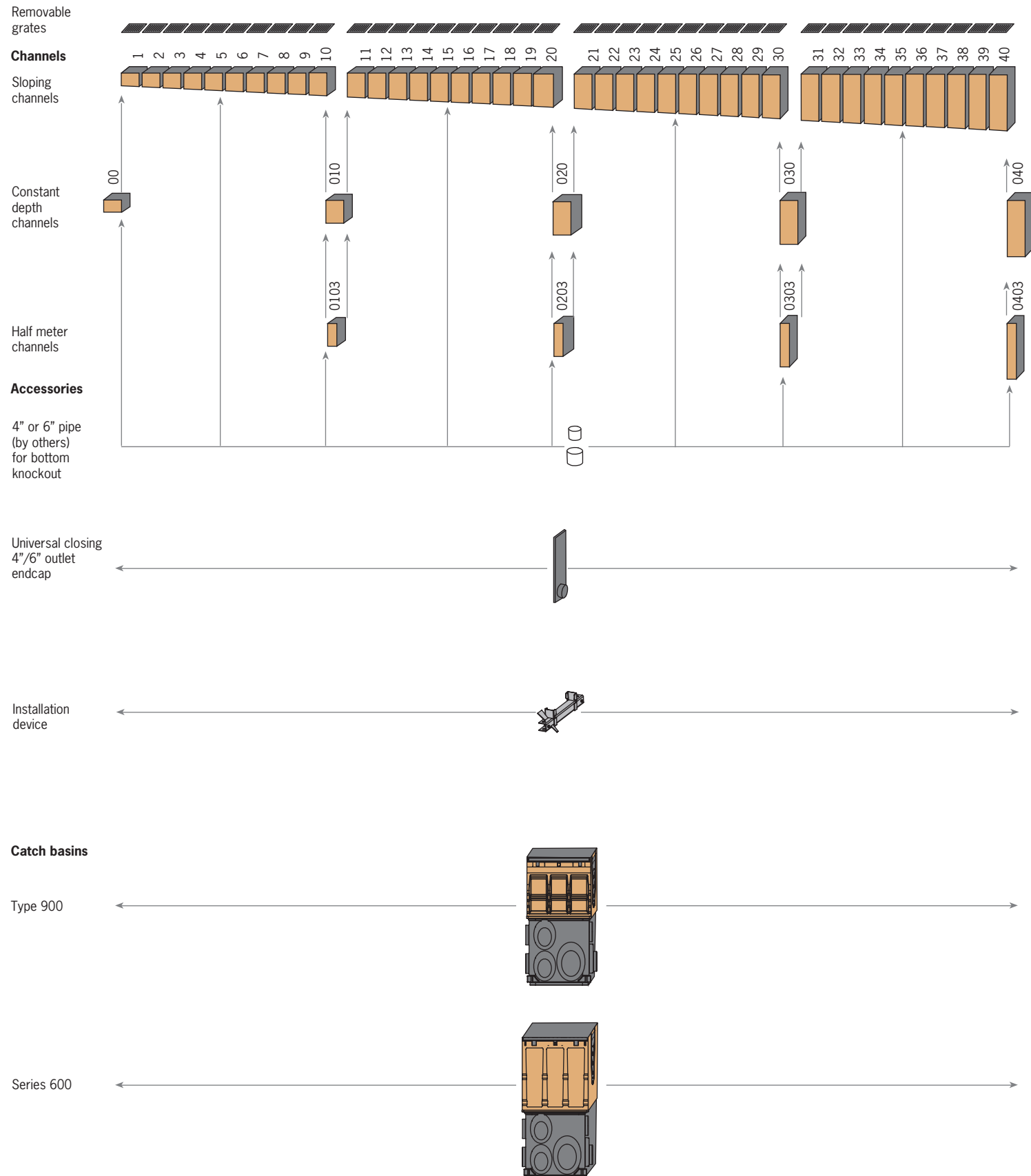

PowerDrain - S200K

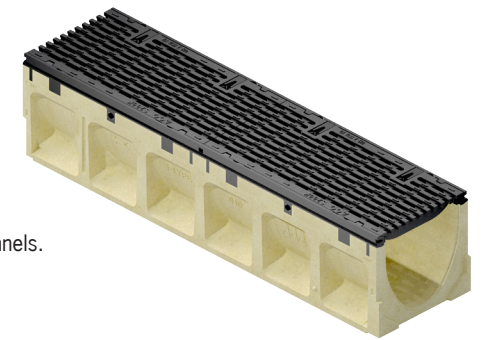

Meter channels - sloping & constant depth

0.5% sloped channels with ductile iron edge rail, in meter lengths and 40 depths which connect to create 40 meter (131'-2") continuously sloping run.

Constant depth channels are available in 5 depths. Can be used to create non-sloped runs, or inserted in sloped runs to increase length.

Bottom knockouts on all constant depths and 5, 10, 15, 20, 25, 30, 35, 40 channels.

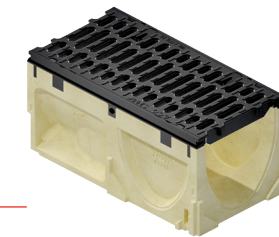

Half meter channels

Constant depth channels with ductile iron edge rail, in 4 depths supplement meter channels. Side knockout and profiling enable side junction to be created. Bottom knockouts on all half meter channels.



Closing/4 in. or 6 in. outlet cap

Fits all channels and manufactured from black polypropylene to complement edge rail. Guides aid cutting to correct height. Wings clip cap onto end of channel. 4" and 6" bell end provides connection to Schedule 40 pipe. Seal using appropriate flexible sealant.

Note: For depth 1-10 channels, ACO recommends removal of unused sections of bell end to ensure adequate pavement material coverage.

Installation device

Fits molded recesses on body of channel. Provides height and joint alignment - a sliding clamp locks the two channels together. Bolt to rebar on either side of channel to hold channels in place during concrete pour. Not reusable; it is 'lost' within concrete haunch.

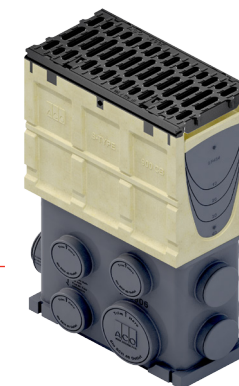
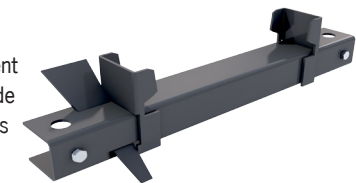

Type 902D In-line catch basin

Two part in-line catch basin with ductile iron edge rail; bases have 4", 6" and 8" drill-outs for pipe connections. Supplied with plastic trash bucket.

Any channel can be connected to catch basin by removing the end wall to the correct height with a box cutter. Cut-out guides provided for connection to channels 00, 010, 020, 030 and 040. All cut-outs to receive male channel ends. One blanking end plate supplied with in-line catch basin.

Series 600D catch basin

A two part in-line catch basin with ductile iron edge rail; bases have 4", 6" and 8" drill-outs for pipe connections. Supplied with plastic trash bucket. Optional riser available for increased depth. Contact ACO for non-polyethylene riser/bases.

Any channel can be connected to catch basin by removing the end/side wall to the correct height. Drill-out guides provided for connection to channels 00, 010, 020, 030 and 040. All cut-outs to receive male channel ends. Two blanking end plates supplied with inline catch basin.



Meter channels

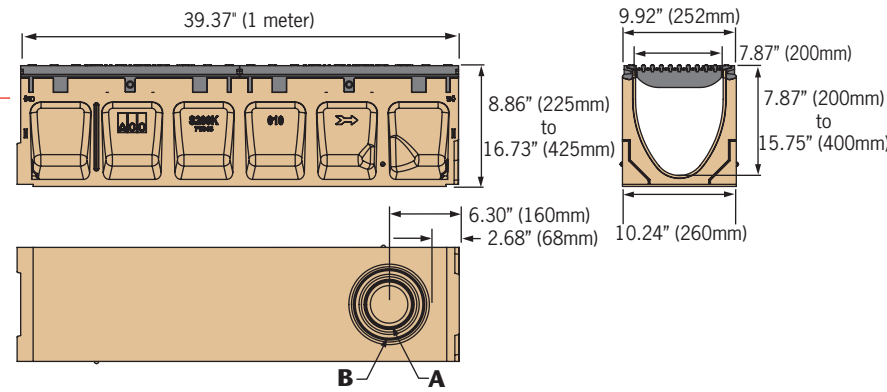

Half meter channels

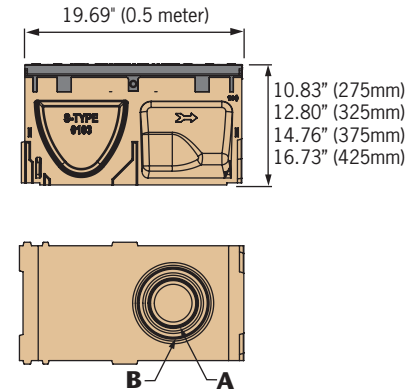

Closing/4 in. or 6 in. outlet cap

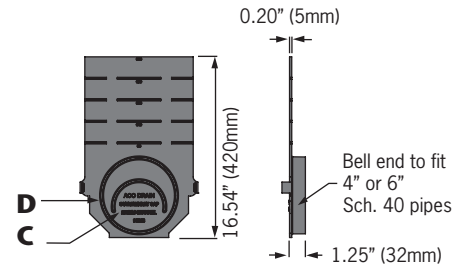

Installation device

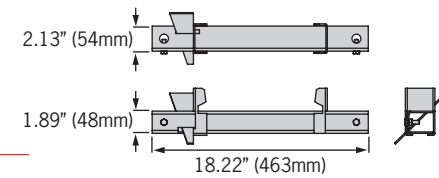

SK2-902D In-line catch basin

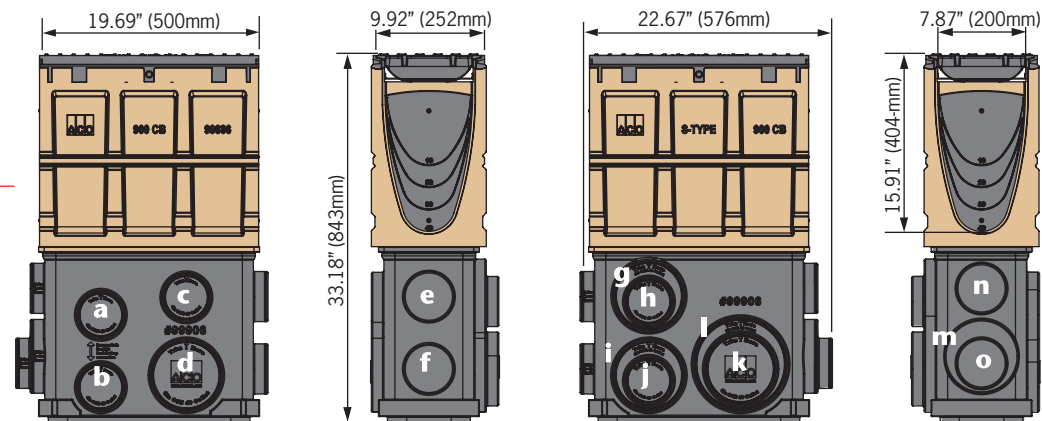

Outlet flow rates

Channels		Invert in.	GPM	CFS
A	SK2-00 - 4" round	7.87"	153	0.34
A	SK2-40 - 4" round	15.75"	216	0.48
B	SK2-00 - 6" round	7.87"	344	0.77
B	SK2-40 - 6" round	15.75"	486	1.08
C	SK2-00 - 4" round	7.87"	132	0.29
C	SK2-40 - 4" round	15.75"	202	0.45
D	SK2-10 - 6" round	9.84"	320	0.71
D	SK2-40 - 6" round	15.75"	437	0.97

PowerDrain S200K

Catch basins	Outlet	Size (Sch 40)	SK2-902D			SK2-621D			SK2-631D		
			Invert in.	GPM	CFS	Invert in.	GPM	CFS	Invert in.	GPM	CFS
	a	4" round	25.33"	263	0.59	29.80"	287	0.64	41.80"	343	0.77
	b	4" round	31.83"	297	0.66	36.29"	319	0.71	48.29"	370	0.83
	c	4" round	23.76"	254	0.57	28.22"	279	0.62	40.22"	337	0.75
	d	6" round	31.83"	658	1.47	36.29"	707	1.57	48.29"	824	1.84
	e	4" round	23.91"	255	0.57	28.37"	280	0.62	40.37"	337	0.75
	f	4" round	30.40"	290	0.65	34.87"	312	0.70	46.87"	365	0.81
	g	6" round	24.68"	570	1.27	29.15"	626	1.40	41.15"	757	1.69
	h	4" round	24.13"	256	0.57	28.59"	281	0.63	40.59"	338	0.75
	i	6" round	31.82"	658	1.47	36.28"	707	1.57	48.28"	824	1.84
	j	4" round	31.26"	294	0.66	35.72"	316	0.70	47.72"	368	0.82
	k	6" round	31.26"	651	1.45	35.72"	701	1.56	47.72"	819	1.83
	l	8" round	31.82"	1149	2.56	36.28"	1237	2.76	48.28"	1449	3.23
	m	6" round	30.32"	640	1.43	34.78"	690	1.54	46.78"	810	1.81
	n	4" round	23.19"	251	0.56	27.65"	276	0.61	39.65"	334	0.74
	o	4" round	29.90"	288	0.64	34.36"	310	0.69	46.36"	363	0.81

Note: These are pipe flow rates at specified outlet, NOT channel flow rates. Catch basin flow rates without trash bucket - using trash bucket reduces flow.

SK2-621D catch basin

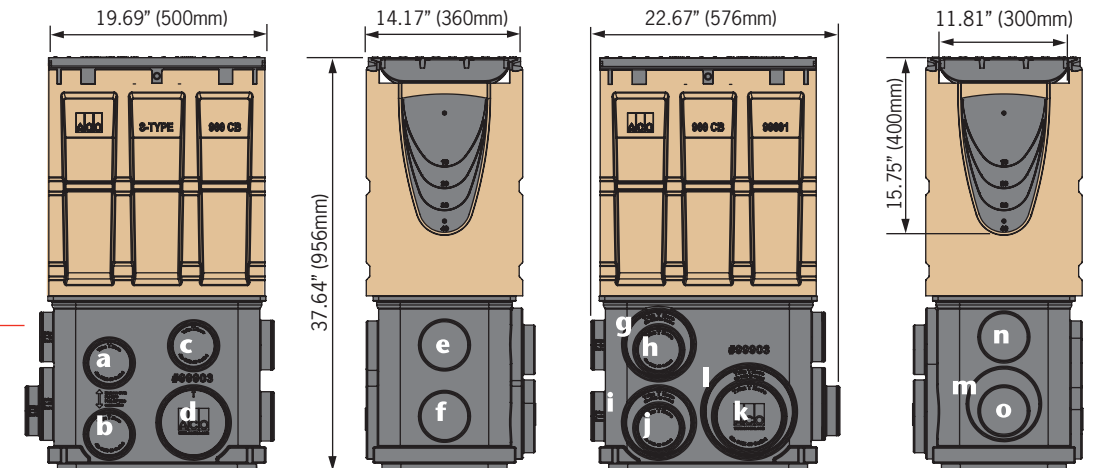

SK2-631D catch basin

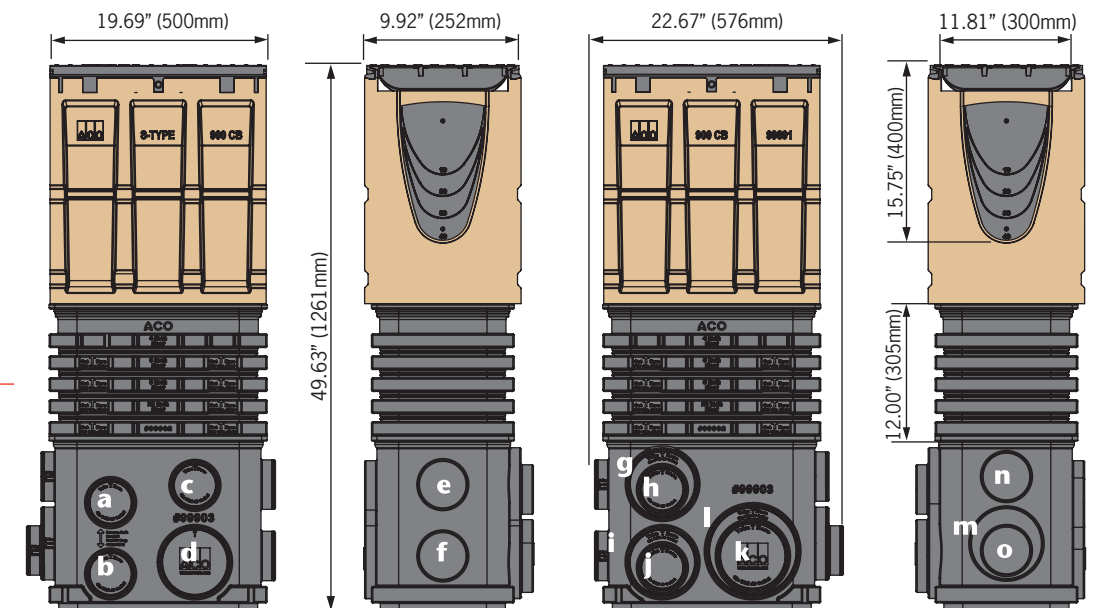

ACO DRAIN

S200K Parts table

	Part No.	Invert Depth				Overall Depth				Vol Gal	Wgt lbs
		Inches		mm		Inches		mm			
		female	male	female	male	female	male	female	male		
SK2-00 Constant depth channel - 39.37" (1m) ²	68041	7.87	7.87	200	200	8.86	8.86	225	225	7.54	85.2
SK2-1 Sloped channel - 39.37" (1m)	68001	7.87	8.07	200	205	8.86	9.06	225	230	7.94	85.2
SK2-2 Sloped channel - 39.37" (1m)	68002	8.07	8.27	205	210	9.06	9.25	230	235	8.13	86.3
SK2-3 Sloped channel - 39.37" (1m)	68003	8.27	8.46	210	215	9.25	9.45	235	240	8.33	87.4
SK2-4 Sloped channel - 39.37" (1m)	68004	8.46	8.66	215	220	9.45	9.65	240	245	8.53	88.5
SK2-5 Sloped channel - 39.37" (1m) ²	68005	8.66	8.86	220	225	9.65	9.84	245	250	8.74	89.6
SK2-6 Sloped channel - 39.37" (1m)	68006	8.86	9.06	225	230	9.84	10.04	250	255	8.95	90.7
SK2-7 Sloped channel - 39.37" (1m)	68007	9.06	9.25	230	235	10.04	10.24	255	260	9.16	91.8
SK2-8 Sloped channel - 39.37" (1m)	68008	9.25	9.45	235	240	10.24	10.43	260	265	9.37	92.9
SK2-9 Sloped channel - 39.37" (1m)	68009	9.45	9.65	240	245	10.43	10.63	265	270	9.58	94.0
SK2-10 Sloped channel - 39.37" (1m) ²	68010	9.65	9.84	245	250	10.63	10.83	270	275	9.79	95.1
SK2-010 Constant depth channel - 39.37" (1m) ²	68043	9.84	9.84	250	250	10.83	10.83	275	275	9.59	95.2
SK2-0103 Constant depth channel - 19.69" (0.5m) ²	68044	9.84	9.84	250	250	10.83	10.83	275	275	4.80	61.2
SK2-11 Sloped channel - 39.37" (1m)	68011	9.84	10.04	250	255	10.83	11.02	275	280	10.01	96.2
SK2-12 Sloped channel - 39.37" (1m)	68012	10.04	10.24	255	260	11.02	11.22	280	285	10.22	97.3
SK2-13 Sloped channel - 39.37" (1m)	68013	10.24	10.43	260	265	11.22	11.42	285	290	10.44	98.4
SK2-14 Sloped channel - 39.37" (1m)	68014	10.43	10.63	265	270	11.42	11.61	290	295	10.66	99.6
SK2-15 Sloped channel - 39.37" (1m) ²	68015	10.63	10.83	270	275	11.61	11.81	295	300	10.88	100.7
SK2-16 Sloped channel - 39.37" (1m)	68016	10.83	11.02	275	280	11.81	12.01	300	305	11.10	101.8
SK2-17 Sloped channel - 39.37" (1m)	68017	11.02	11.22	280	285	12.01	12.20	305	310	11.32	102.9
SK2-18 Sloped channel - 39.37" (1m)	68018	11.22	11.42	285	290	12.20	12.40	310	315	11.54	104.0
SK2-19 Sloped channel - 39.37" (1m)	68019	11.42	11.61	290	295	12.40	12.60	315	320	11.76	105.1
SK2-20 Sloped channel - 39.37" (1m) ²	68020	11.61	11.81	295	300	12.60	12.80	320	325	11.98	106.2
SK2-020 Constant depth channel - 39.37" (1m) ²	68045	11.81	11.81	300	300	12.80	12.80	325	325	11.78	106.2
SK2-0203 Constant depth channel - 19.69" (0.5m) ²	68046	11.81	11.81	300	300	12.80	12.80	325	325	5.89	68.8
SK2-21 Sloped channel - 39.37" (1m)	68021	11.81	12.01	300	305	12.80	12.99	325	330	12.21	107.3
SK2-22 Sloped channel - 39.37" (1m)	68022	12.01	12.20	305	310	12.99	13.19	330	335	12.42	108.4
SK2-23 Sloped channel - 39.37" (1m)	68023	12.20	12.40	310	315	13.19	13.39	335	340	12.65	109.5
SK2-24 Sloped channel - 39.37" (1m)	68024	12.40	12.60	315	320	13.39	13.58	340	345	12.87	110.6
SK2-25 Sloped channel - 39.37" (1m) ²	68025	12.60	12.80	320	325	13.58	13.78	345	350	13.10	111.7
SK2-26 Sloped channel - 39.37" (1m)	68026	12.80	12.99	325	330	13.78	13.98	350	355	13.32	112.3
SK2-27 Sloped channel - 39.37" (1m)	68027	12.99	13.19	330	335	13.98	14.17	355	360	13.56	113.9
SK2-28 Sloped channel - 39.37" (1m)	68028	13.19	13.39	335	340	14.17	14.37	360	365	13.77	115.8
SK2-29 Sloped channel - 39.37" (1m)	68029	13.39	13.58	340	345	14.37	14.57	365	370	13.99	116.1
SK2-30 Sloped channel - 39.37" (1m) ²	68030	13.58	13.78	345	350	14.57	14.76	370	375	14.22	117.2
SK2-030 Constant depth channel - 39.37" (1m) ²	68047	13.78	13.78	350	350	14.76	14.76	375	375	14.01	117.2
SK2-0303 Constant depth channel - 19.69" (0.5m) ²	68048	13.78	13.78	350	350	14.76	14.76	375	375	7.05	73.3
SK2-31 Sloped channel - 39.37" (1m)	68031	13.78	13.98	350	355	14.76	14.96	375	380	14.44	118.4
SK2-32 Sloped channel - 39.37" (1m)	68032	13.98	14.17	355	360	14.96	15.16	380	385	14.67	119.5
SK2-33 Sloped channel - 39.37" (1m)	68033	14.17	14.37	360	365	15.16	15.35	385	390	14.89	120.6
SK2-34 Sloped channel - 39.37" (1m)	68034	14.37	14.57	365	370	15.35	15.55	390	395	15.11	121.7
SK2-35 Sloped channel - 39.37" (1m) ²	68035	14.57	14.76	370	375	15.55	15.75	395	400	15.34	122.8
SK2-36 Sloped channel - 39.37" (1m)	68036	14.76	14.96	375	380	15.75	15.94	400	405	15.56	123.9
SK2-37 Sloped channel - 39.37" (1m)	68037	14.96	15.16	380	385	15.94	16.14	405	410	15.78	125.0
SK2-38 Sloped channel - 39.37" (1m)	68038	15.16	15.35	385	390	16.14	16.34	410	415	16.02	126.1
SK2-39 Sloped channel - 39.37" (1m)	68039	15.35	15.55	390	395	16.34	16.54	415	420	16.23	127.2
SK2-40 Sloped channel - 39.37" (1m) ²	68040	15.55	15.75	395	400	16.54	16.73	420	425	16.46	128.3
SK2-040 Constant depth channel - 39.37" (1m) ²	68049	15.75	15.75	400	400	16.73	16.73	425	425	16.27	128.3
SK2-0403 Constant depth channel - 19.69" (0.5m) ²	68050	15.75	15.75	400	400	16.73	16.73	425	425	8.14	82.1
Universal end cap	96823	15.75	15.75	400	400	16.54	16.54	420	420	-	1.4
Debris strainer for 4" bottom knockout	93488	-	-	-	-	-	-	-	-	-	0.2
Installation device	97478	-	-	-	-	-	-	-	-	-	4.0
Grate removal tool	01318	-	-	-	-	-	-	-	-	-	0.3

Notes:

1. PowerDrain is sold as channel only. Choose appropriate grate from page 84.
2. Preformed 4" & 6" dia knock-outs cast on underside of certain channels (00, 5, 10, 010, 0103, 15, 20, 020, 0203, 25, 30, 030, 0303, 35, 40, 040, 0403).
3. Closing/outlet cap can be cut down to suit all channels.
4. Catch basin details on page 83.
5. Debris strainer details for 4" dia. outlet on page 103.

PowerDrain S200K

Polymer concrete catch basins

Polymer concrete catch basins are used either as stand alone area drains or more commonly as the outlet to a trench run. They provide the highest hydraulic output and allow easy access to pipe system for maintenance.

Type 902D provides an in-line catch basin (same width and visually indistinguishable from trench run) and the Series 600D is 12" wide and provides greater hydraulic output.

SK2-Type 902D 8 in. wide In-line catch basin

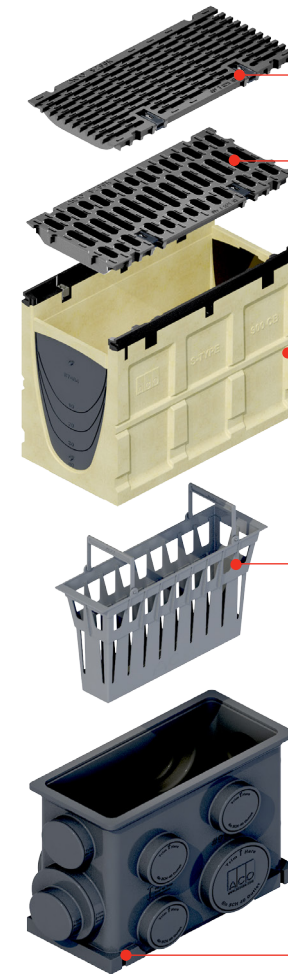

Series 600 grates - choice of Class F slotted or Class E longitudinal ADA compliant ductile iron grates with PowerLok™ boltless locking or Class F slotted ductile iron 4-bolt grate. *See page 94.*

Type 900 grates - choice of Class F slotted or Class E longitudinal ADA compliant ductile iron grates supplied with PowerLok™ boltless locking or Class F slotted ductile iron 4-bolt grate. *See page 84.*

Top section - polymer concrete with integrally cast-in ductile iron frame for grate. Guides aid connection of male channel ends at #10,20,30 and 40 depths. Other channels can be connected by removing wall to required height. Blanking end rail supplied with SK2-902D and kit available for Series 600D. *See page 155.*

Trash bucket - plastic trash bucket designed to collect debris washed from trench run. Supported in catch basin top to avoid creation of a vacuum and flow reduction. SK2-631D uses deep bucket with riser.

Riser - a plastic riser, supplied with SK2-631D, designed to provide additional catch basin depth and hydraulic output. Guides enable cutting to size at 2" (50mm) intervals - minimum 2" and maximum 12" height. Additional units can be used (a maximum of 2 is recommended to ensure snake access is maintained and for structural stability). Contact ACO for non-polyethylene riser.

Base - polyethylene bases with wide range of Schedule 40 4", 6" and 8" cut-outs for easy pipe connection. Cut-outs on end and side allow connection of ACO foul air trap. Contact ACO for non-polyethylene bases.

SK2-Series 600D 12 in. wide catch basin

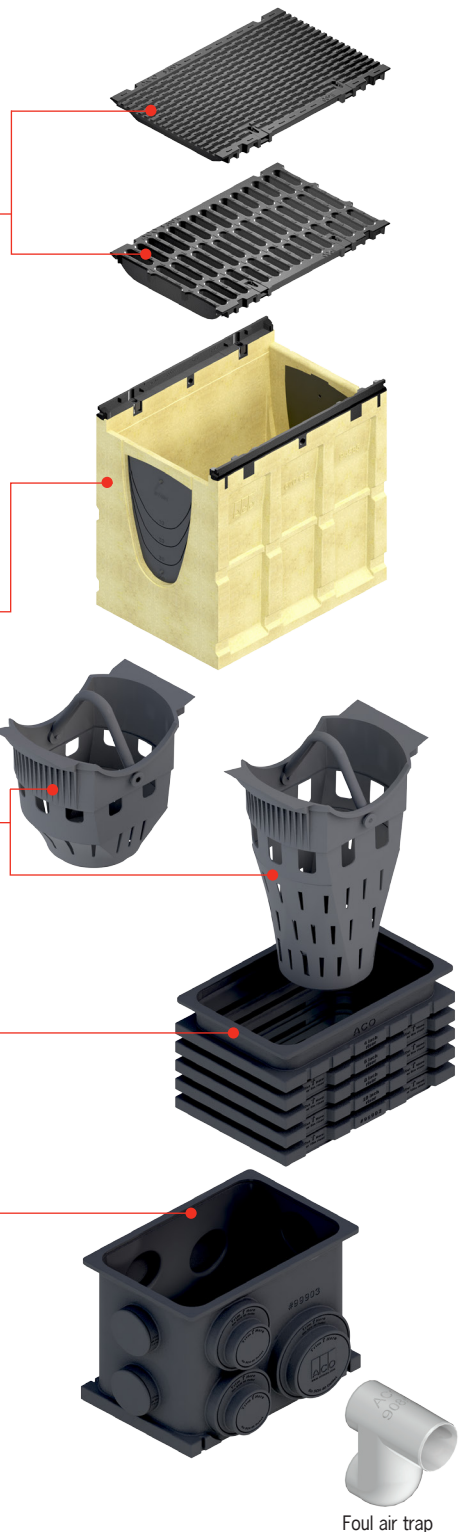

Parts table - S200K Catch basins

	Part No.	Volume Gallons*	Weight lbs
SK2-902D in-line catch basin - 19.69" (0.5m)	68053	18.1	81.8
SK2-621D catch basin - 19.69" (0.5m)	68055	30.4	116.0
SK2-631D catch basin - 19.69" (0.5m)	68056	40.2	126.0
Series 600 optional riser	99902	9.8	10.0
Foul air trap - fits both Type 902D & 600 basins	90854	-	1.2

* Volume is up to grate seat and without trash bucket.

ACO DRAIN

Available S200K grates

Description	Part No.	Length inches (m)	Slot Size inches	Intake area sq. in.	Wgt lbs	PL	✓	✗	✓	55.6
E Load Class E - 135,000lbs - EN1433 2,321psi Industrial										
Longitudinal iron										
Iron	72263	19.69" (0.5m)	1.34 x 0.43	52.4	26.4	PL	✓	✗	✓	55.6
Ductile iron to ASTM A 536-84 - minimum grade 65-45-12 This grate complies with RRF-621E '200,000lb proof load' test.										
F Load Class F - 200,000lbs - EN1433 3,481psi Heavy duty										
Slotted iron										
Iron	02449	19.69" (0.5m)	0.71 x 3.62 avg.	70.1	30.8	PL	✗	✗	✓	21.4
Ductile iron to ASTM A 536-84 - minimum grade 65-45-12 This grate complies with RRF-621E '200,000lb proof load' test.										
4-bolt iron										
Iron*	99591	19.69" (0.5m)	0.71 x 3.62 avg.	71.3	26.4	Bolt	✗	✗	✓	21.4
Ductile iron to ASTM A 536-84 - minimum grade 65-45-12 This grate complies with RRF-621E '200,000lb proof load' test. * Supplied with bolts.										

- Key**
- Locking mechanism
 - 200,000lb proof load compliant (Page 128)
 - Compliant with Americans with Disabilities Act of 1990 Section 4.5.4 (Page 140)
 - Bicycle Safe compliant to Australian Standard AS 3996 - 2006 (Page 140)
 - ASME A112.6.3 - 2001 Heel resistant less than 0.31" (8mm) (Page 140)
 - Anti-slip grates - BPN over 24 (Page 140)

Choosing S200K grates

There are three available grate styles to fit the S200K heavy duty channel body.

The conventional slotted grate, with PowerLok™, gives an excellent all-around heavy duty solution with the ease of the PowerLok™ locking/unlocking mechanism. Ideal for use where regular removal of the grate for maintenance is required.

The ADA compliant, longitudinal slotted grate, with PowerLok™, gives the ideal solution to a heavy duty location where some pedestrian access may be required.

Although easy locking and grate removal is important for maintenance, some specific applications require a 4-bolt solution. The four threaded stainless steel inserts in the S200K channel body allow a 4-bolt grate to be bolted into the channel for ultimate stiffness and security. Tamper resistant bolts can also be used.

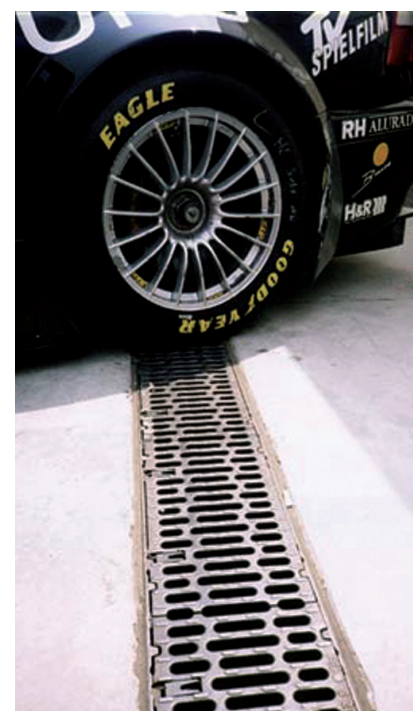

PowerDrain S200K

PowerLok™ - boltless locking system



1
Fit grate

To lock, position side of grate into lugs on rail, place hook part of tool into 'V' and push towards rail.



2
Grate removal

To open PowerLok™, insert tool between rail and PowerLok™ device.



3
Grate removal

Rotate tool 90°, PowerLok™ device should push away from rail.

PowerLok™ - safety clip

For areas of extra security or safety concerns, an optional safety clip is available that provides a visual alert if the PowerLok™ devices are left open. The clip push fits next to the PowerLok™ device and sits level with the grate when the grate is locked. The clip cannot be fitted if the PowerLok™ is open. If all grates are engaged, a run of red dots is visible.

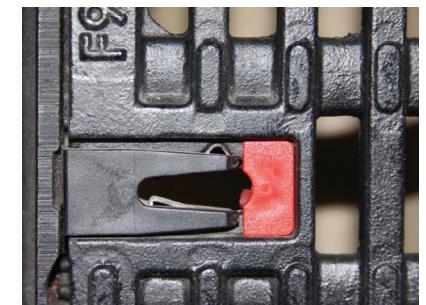

4-Bolt grates



1
Fit grate

Position grate onto channel, align holes in grate with matching holes in edge rail.



2
Fit grate

Using wrench or socket set to tighten. If using a torque wrench, do not set to more than 15 ft. lbs.



3
Grate removal

To remove grates, use wrench or socket set. Carefully store bolts for refitting of grates.

Grate accessories

	Part No.	Weight lbs
PowerLok safety clip (red)	10443	0.1
Replacement bolt for 4-bolt grate	95526	0.1
Tamper resistant bolt for 4-bolt grate	138127	0.1
Tamper resistant bolt drive	138128	0.1



Requires tamper resistant drive bit



S300K - 12" wide heavy duty system

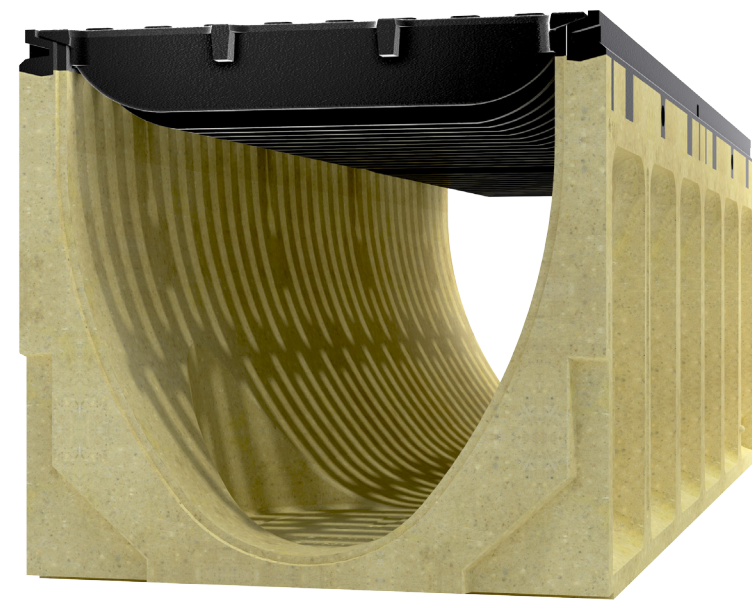
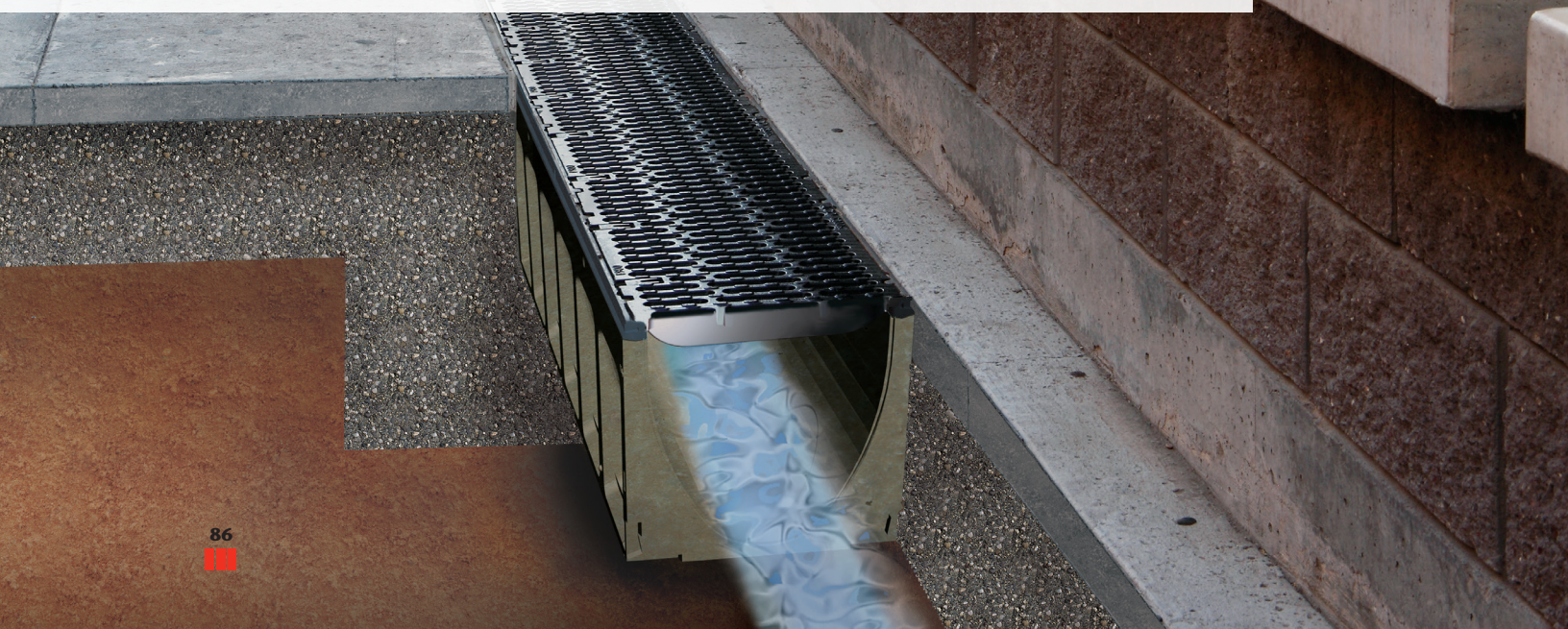

S300K is a 12" wide system with choice of Class F (90 ton) slotted or Class E (60 ton) ADA compliant ductile iron grates featuring the patented PowerLok™ boltless locking system. A 4-bolt slotted grate is also available.

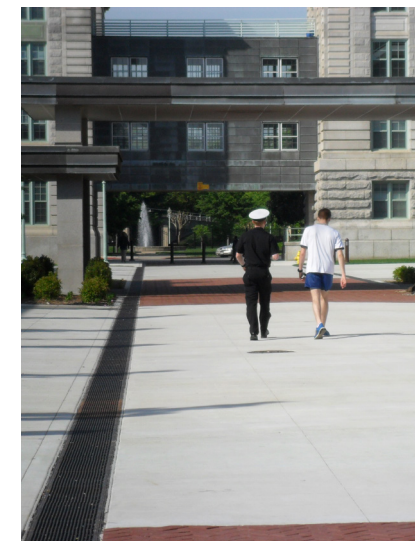

PowerDrain S300K



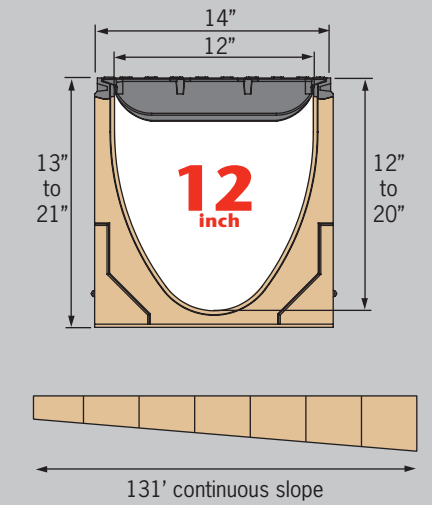



Key Dimensions



Typical applications

- Airports
- Highways
- Heavy duty industrial areas
- Gas stations
- Docks & ports
- Military bases
- Truck stops

Selection criteria

- A B C D E F** Light to heavy industrial duty loads 
-  Product can be used towards LEED & EPA requirements
-  Resistant to many everyday chemicals. *Check page 139*
-  Multiple grate options to meet legal requirements
-  Multiple grate options to meet design requirements
-  Increased hydraulic capacity
-  Constant depth and/or sloped depth channels

ACO DRAIN

System layout

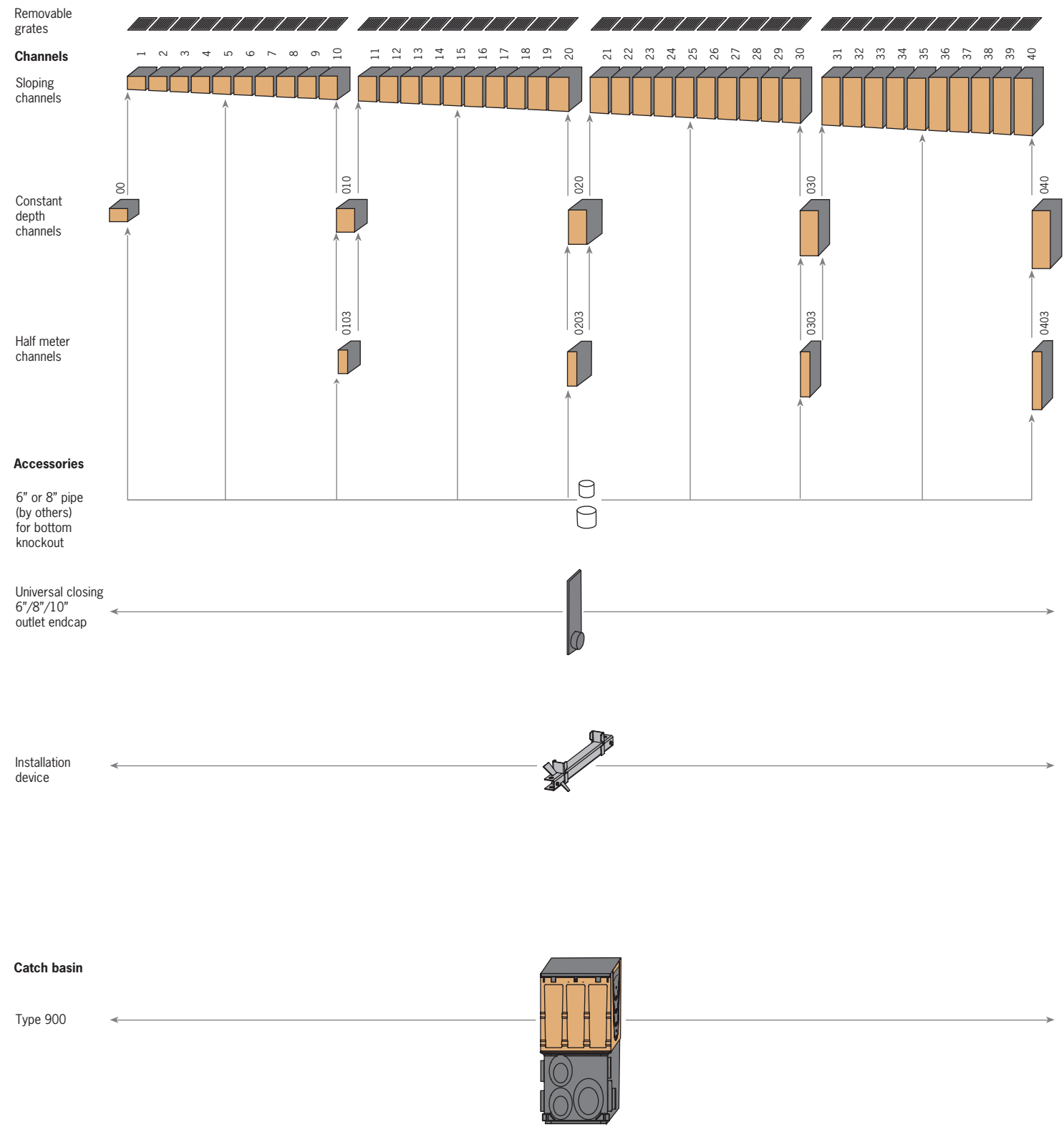

Meter channels - sloping & constant depth

0.5% sloped channels with ductile iron edge rail; in meter lengths and 40 depths which connect to create 40 meter (131'-2") continuously sloping run.

Constant depth channels are available in 5 depths. Can be used to create non-sloped runs, or inserted in sloped runs to increase length.

Bottom knockouts on all constant depths and 5, 10, 15, 20, 25, 30, 35, 40 channels.

PowerDrain - S300K

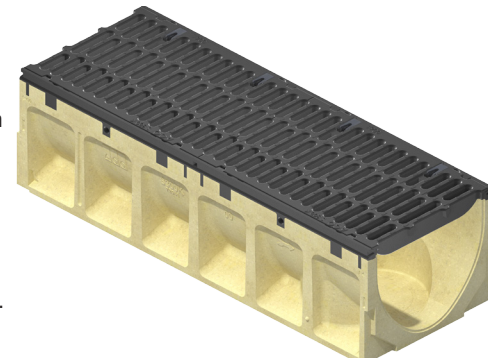

Half meter channels

Constant depth channels with ductile iron edge rail; in 4 depths supplement meter channels. Side knockout and profiling enable side junction to be created. Bottom knockouts on all half meter channels.



Closing/6 in., 8 in. or 10 in. outlet cap

Fits all channels and manufactured from black polypropylene to complement edge rail. Guides aid cutting to correct height. Wings clip cap onto end of channel. 6", 8" and 10" bell end provides connection to Schedule 40 pipe. Seal using appropriate flexible sealant.

Note: For depth 1-10 channels, ACO recommends removal of unused sections of bell end to ensure adequate pavement material coverage.



Installation device

Fits molded recesses on body of channel. Provides height and joint alignment - a sliding clamp locks the two channels together. Bolt to rebar on either side of channel to hold channels in place during concrete pour. Not reusable; it is 'lost' within concrete haunch.

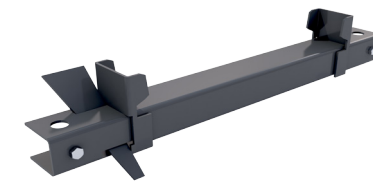

Type 903D/904D In-line catch basins

A two part in-line catch basin with ductile iron edge rail; bases have 4", 6" and 8" drill-outs for pipe connections. Supplied with plastic trash bucket. Optional riser available for increased depth. Contact ACO for non-polyethylene riser/bases.

Any channel can be connected to catch basin by removing the end/side wall to the correct height. Drill out guides provided for connection to channels 00, 010, 020, 030 and 040. All cut-outs to receive male channel ends. Blanking end rail supplied to stop concrete ingress during final pour.

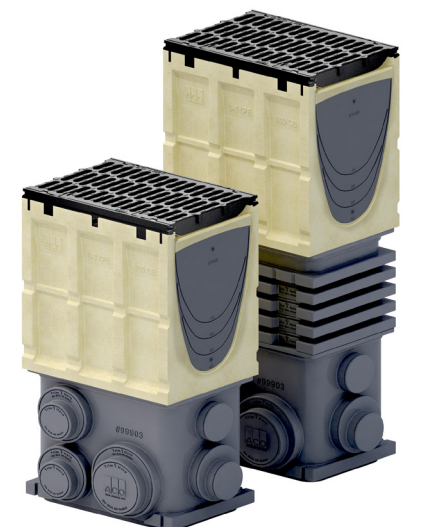

Meter channels

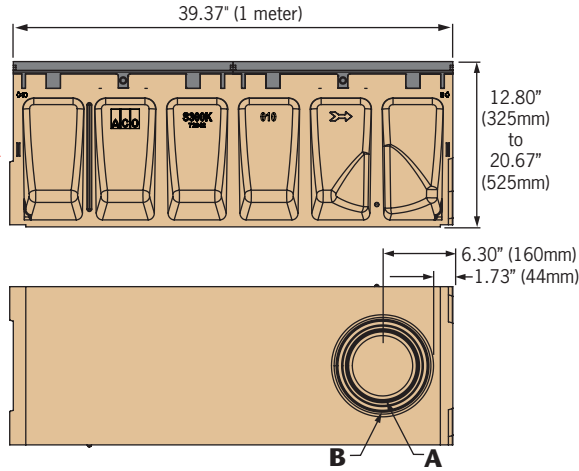

Half meter channels

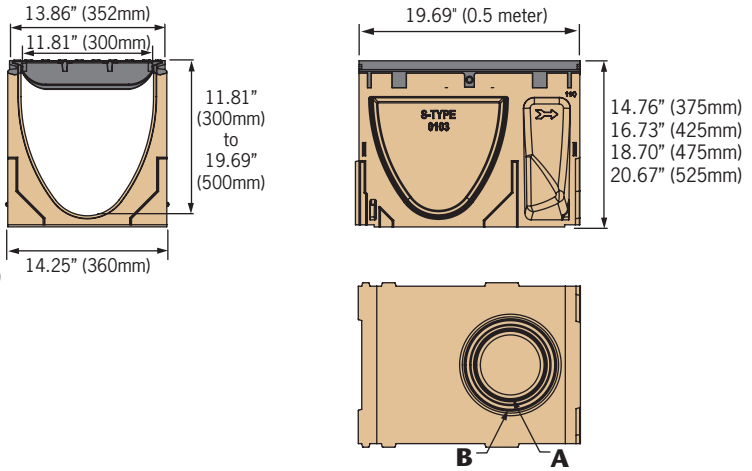

Outlet flow rates

Channels		Invert in.	GPM	CFS
A	SK3-00 - 6" round	11.81"	421	0.94
A	SK3-40 - 6" round	19.69"	544	1.21
B	SK3-00 - 8" round	11.81"	748	1.67
B	SK3-40 - 8" round	19.69"	966	2.15
C	SK3-00 - 6" round	11.81"	364	0.81
C	SK3-40 - 6" round	19.69"	500	1.11
D	SK3-10 - 8" round	13.78"	681	1.52
D	SK3-40 - 8" round	19.69"	863	1.92
E	SK3-20 - 10" round	15.75"	1116	2.49
E	SK3-40 - 10" round	19.69"	1304	2.91

Catch basins		SK3-903D			SK3-904D		
Outlet Size (Sch 40)	Invert in.	GPM	CFS	Invert in.	GPM	CFS	
a	4" round	29.80"	287	0.64	41.80"	343	0.77
b	4" round	36.29"	319	0.71	48.29"	370	0.83
c	4" round	28.22"	279	0.62	40.22"	337	0.75
d	6" round	36.29"	707	1.57	48.29"	824	1.84
e	4" round	28.37"	280	0.62	40.37"	337	0.75
f	4" round	34.87"	312	0.70	46.87"	365	0.81
g	6" round	29.15"	626	1.40	41.15"	757	1.69
h	4" round	28.59"	281	0.63	40.59"	338	0.75
i	6" round	36.28"	707	1.57	48.28"	824	1.84
j	4" round	35.72"	316	0.70	47.72"	368	0.82
k	6" round	35.72"	701	1.56	47.72"	819	1.83
l	8" round	36.28"	1237	2.76	48.28"	1449	3.23
m	6" round	34.78"	690	1.54	46.78"	810	1.81
n	4" round	27.65"	276	0.61	39.65"	334	0.74
o	4" round	34.36"	310	0.69	46.36"	363	0.81

Note: These are pipe flow rates at specified outlet, NOT channel flow rates. Catch basin flow rates without trash bucket - using trash bucket reduces flow.

Closing/6 in., 8 in. or 10 in. outlet cap

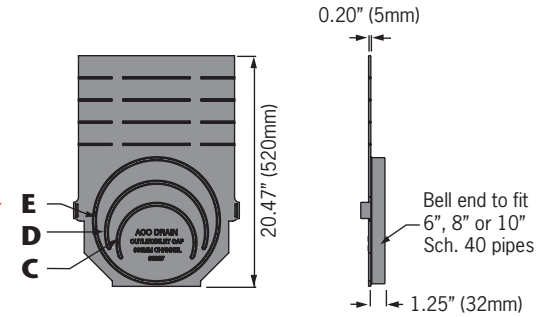

Installation device

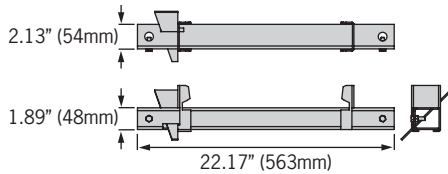

SK3-903D In-line catch basin

SK3-904D In-line catch basin

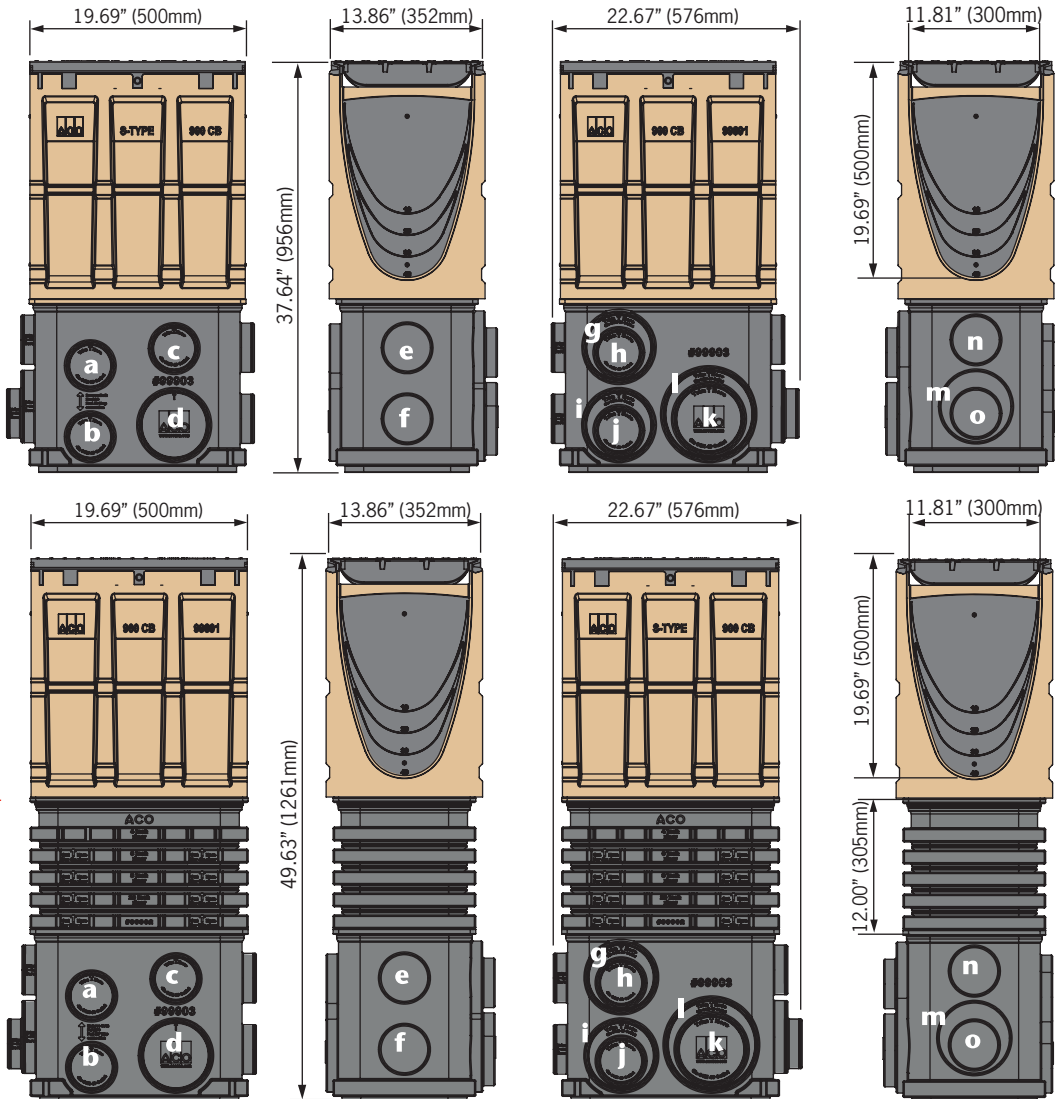

ACO DRAIN

S300K Parts table

	Part No.	Invert Depth				Overall Depth				Vol Gal	Wgt lbs
		Inches		mm		Inches		mm			
		female	male	female	male	female	male	female	male		
SK3-00 Constant depth channel - 39.37" (1m) ²	69041	11.81	11.81	300	300	12.80	12.80	325	325	18.01	140.0
SK3-1 Sloped channel - 39.37" (1m)	69001	11.81	12.01	300	305	12.80	12.99	325	330	19.58	140.0
SK3-2 Sloped channel - 39.37" (1m)	69002	12.01	12.20	305	310	12.99	13.19	330	335	20.01	141.3
SK3-3 Sloped channel - 39.37" (1m)	69003	12.20	12.40	310	315	13.19	13.39	335	340	20.44	142.8
SK3-4 Sloped channel - 39.37" (1m)	69004	12.40	12.60	315	320	13.39	13.58	340	345	20.86	144.1
SK3-5 Sloped channel - 39.37" (1m) ²	69005	12.60	12.80	320	325	13.58	13.78	345	350	21.28	145.4
SK3-6 Sloped channel - 39.37" (1m)	69006	12.80	12.99	325	330	13.78	13.98	350	355	21.69	146.9
SK3-7 Sloped channel - 39.37" (1m)	69007	12.99	13.19	330	335	13.98	14.17	355	360	22.11	148.2
SK3-8 Sloped channel - 39.37" (1m)	69008	13.19	13.39	335	340	14.17	14.37	360	365	22.51	149.5
SK3-9 Sloped channel - 39.37" (1m)	69009	13.39	13.58	340	345	14.37	14.57	365	370	22.92	150.9
SK3-10 Sloped channel - 39.37" (1m) ²	69010	13.58	13.78	345	350	14.57	14.76	370	375	23.32	152.3
SK3-010 Constant depth channel - 39.37" (1m) ²	69042	13.78	13.78	350	350	14.76	14.76	375	375	21.22	152.3
SK3-0103 Constant depth channel - 19.69" (0.5m) ²	69045	13.78	13.78	350	350	14.76	14.76	375	375	10.61	84.2
SK3-11 Sloped channel - 39.37" (1m)	69011	13.78	13.98	350	355	14.76	14.96	375	380	23.72	153.6
SK3-12 Sloped channel - 39.37" (1m)	69012	13.98	14.17	355	360	14.96	15.16	380	385	24.11	155.0
SK3-13 Sloped channel - 39.37" (1m)	69013	14.17	14.37	360	365	15.16	15.35	385	390	24.51	156.4
SK3-14 Sloped channel - 39.37" (1m)	69014	14.37	14.57	365	370	15.35	15.55	390	395	24.89	157.7
SK3-15 Sloped channel - 39.37" (1m) ²	69015	14.57	14.76	370	375	15.55	15.75	395	400	25.27	149.1
SK3-16 Sloped channel - 39.37" (1m)	69016	14.76	14.96	375	380	15.75	15.94	400	405	25.68	160.5
SK3-17 Sloped channel - 39.37" (1m)	69017	14.96	15.16	380	385	15.94	16.14	405	410	26.06	161.9
SK3-18 Sloped channel - 39.37" (1m)	69018	15.16	15.35	385	390	16.14	16.34	410	415	26.44	163.2
SK3-19 Sloped channel - 39.37" (1m)	69019	15.35	15.55	390	395	16.34	16.54	415	420	26.83	164.6
SK3-20 Sloped channel - 39.37" (1m) ²	69020	15.55	15.75	395	400	16.54	16.74	420	425	27.21	166.0
SK3-020 Constant depth channel - 39.37" (1m) ²	69044	15.75	15.75	400	400	16.73	16.73	425	425	24.53	166.0
SK3-0203 Constant depth channel - 19.69" (0.5m) ²	69047	15.75	15.75	400	400	16.73	16.73	425	425	12.27	92.0
SK3-21 Sloped channel - 39.37" (1m)	69021	15.75	15.94	400	405	16.73	16.93	425	430	27.59	167.3
SK3-22 Sloped channel - 39.37" (1m)	69022	15.94	16.14	405	410	16.93	17.13	430	435	27.97	168.7
SK3-23 Sloped channel - 39.37" (1m)	69023	16.14	16.34	410	415	17.13	17.32	435	440	28.34	170.1
SK3-24 Sloped channel - 39.37" (1m)	69024	16.34	16.54	415	420	17.32	17.52	440	445	28.72	171.4
SK3-25 Sloped channel - 39.37" (1m) ²	69025	16.54	16.73	420	425	17.52	17.72	445	450	29.09	172.7
SK3-26 Sloped channel - 39.37" (1m)	69026	16.73	16.93	425	430	17.72	17.91	450	455	29.47	174.2
SK3-27 Sloped channel - 39.37" (1m)	69027	16.93	17.13	430	435	17.91	18.11	455	460	29.84	175.5
SK3-28 Sloped channel - 39.37" (1m)	69028	17.13	17.32	435	440	18.11	18.31	460	465	30.21	176.8
SK3-29 Sloped channel - 39.37" (1m)	69029	17.32	17.52	440	445	18.31	18.50	465	470	30.58	178.3
SK3-30 Sloped channel - 39.37" (1m) ²	69030	17.52	17.72	445	450	18.50	18.70	470	475	30.95	179.6
SK3-030 Constant depth channel - 39.37" (1m) ²	69046	17.72	17.72	450	450	18.70	18.70	475	475	27.87	179.6
SK3-0303 Constant depth channel - 19.69" (0.5m) ²	69049	17.72	17.72	450	450	18.70	18.70	475	475	13.94	100.0
SK3-31 Sloped channel - 39.37" (1m)	69031	17.72	17.91	450	455	18.70	18.90	475	480	31.32	180.9
SK3-32 Sloped channel - 39.37" (1m)	69032	17.91	18.11	455	460	18.90	19.09	480	485	31.69	182.4
SK3-33 Sloped channel - 39.37" (1m)	69033	18.11	18.31	460	465	19.09	19.29	485	490	32.06	183.7
SK3-34 Sloped channel - 39.37" (1m)	69034	18.31	18.50	465	470	19.29	19.49	490	495	32.42	185.0
SK3-35 Sloped channel - 39.37" (1m) ²	69035	18.50	18.70	470	475	19.49	19.69	495	500	32.79	186.5
SK3-36 Sloped channel - 39.37" (1m)	69036	18.70	18.90	475	480	19.69	19.88	500	505	33.16	187.8
SK3-37 Sloped channel - 39.37" (1m)	69037	18.90	19.09	480	485	19.88	20.08	505	510	33.52	189.1
SK3-38 Sloped channel - 39.37" (1m)	69038	19.09	19.29	485	490	20.08	20.28	510	515	33.88	190.5
SK3-39 Sloped channel - 39.37" (1m)	69039	19.29	19.49	490	495	20.28	20.47	515	520	34.25	191.9
SK3-40 Sloped channel - 39.37" (1m) ²	69040	19.49	19.69	495	500	20.47	20.67	520	525	34.61	193.2
SK3-040 Constant depth channel - 39.37" (1m) ²	69048	19.69	19.69	500	500	20.67	20.67	525	525	31.25	193.2
SK3-0403 Constant depth channel - 19.69" (0.5m) ²	69050	19.69	19.69	500	500	20.67	20.67	525	525	15.63	109.0
SK3 Universal closing/inlet/outlet end cap	96827	19.69	19.69	500	500	20.47	20.47	520	520	-	2.5
Installation device	97479	-	-	-	-	-	-	-	-	-	4.9
Grate removal tool	01318	-	-	-	-	-	-	-	-	-	0.3

- Notes:**
1. PowerDrain is sold as channel only. Choose appropriate grate from page 94.
 2. Preformed 6" & 8" dia knock-outs cast on underside of certain channel (00, 5, 10, 010, 0103, 15, 20, 020, 0203, 25, 30, 030, 0303, 35, 40, 040, 0403).
 3. Closing/outlet cap can be cut down to suit all channels.
 4. Catch basin details on page 93.

PowerDrain S300K

Polymer concrete catch basins

Polymer concrete catch basins are used either as stand alone area drains or more commonly as the outlet to a trench run. They provide the highest hydraulic output and allow easy access to the pipe system for maintenance.

Type 903D and 904D are same width and visually indistinguishable from trench run.

SK3-Type 903D
12 in. wide In-line catch basin



Type 900 grates - choice of Class F slotted or Class E longitudinal ADA compliant ductile iron grates with PowerLok™ boltless locking or Class F slotted ductile iron 4-bolt grate. *See page 94.*

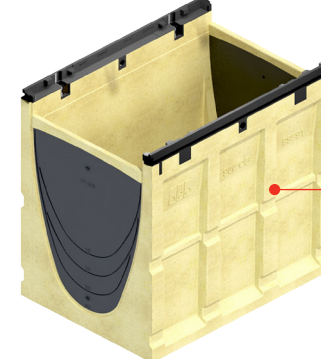

Top section - polymer concrete with integrally cast-in ductile iron frame for grate. End guides aid connection of male channel ends at #10, 20, 30 and 40 depths. Other channels can be connected by removing wall to correct height. Blanking end rail supplied. *See page 155.*



Trash bucket - plastic trash bucket designed to collect debris washed from trench run. Supported in catch basin top to avoid creation of a vacuum and reduction in outflow. Use deeper bucket with riser.

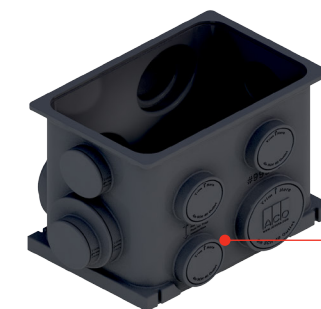

Riser - a plastic riser, supplied with SK3-904D, designed to provide additional catch basin depth and hydraulic output. Guides enable cutting to size at 2" (50mm) intervals - minimum 2" and maximum 12" height. Additional units can be used (a maximum of 2 is recommended to ensure snake access is maintained and for structural stability). Contact ACO for non-polyethylene riser.

Parts table - S300K Catch basins

	Part No.	Volume Gallons*	Weight lbs
SK3-903D In-line catch basin - 19.69" (0.5m)	69053	30.4	99.4
SK3-904D In-line catch basin - 19.69" (0.5m)	69054	40.2	104.4
Optional riser	99902	9.8	10.0
Foul air trap	90854	-	1.2

* Volume is up to grate seat and without trash bucket.

SK3-Type 904D
12 in. wide In-line catch basin (with riser)

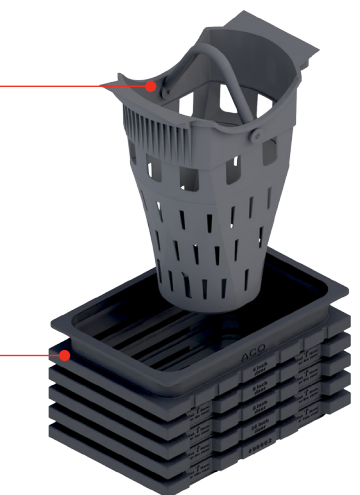
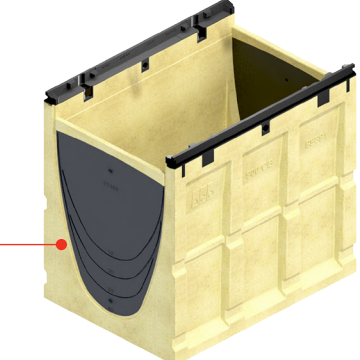
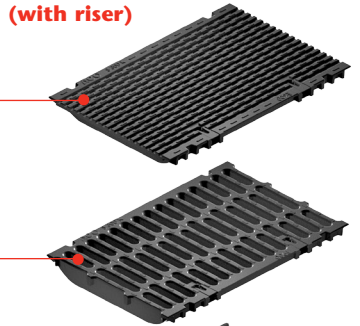

Base - polyethylene bases with wide range of Schedule 40 4", 6" and 8" cut-outs for easy pipe connection. Cut-outs on end and side allow connection of ACO foul air trap. Contact ACO for non-polyethylene bases.

ACO DRAIN

Available S300K grates

Description	Part No.	Length inches (m)	Slot Size inches	Intake area sq. in.	Wgt lbs	PL	✓	✓	✓	48.9
E Load Class E - 135,000lbs - EN1433 2,321psi Industrial										
Longitudinal iron										
Iron	96833	19.69" (0.5m)	0.76 x 0.31	63.2	64.0	PL	✓	✓	✓	48.9
Ductile iron to ASTM A 536-84 - minimum grade 65-45-12										
F Load Class F - 200,000lbs - EN1433 3,481psi Heavy duty										
Slotted iron										
Iron	02445	19.69" (0.5m)	0.71 x 3.61 avg.	122.6	50.0	PL	✗	✗	✓	31.5
Ductile iron to ASTM A 536-84 - minimum grade 65-45-12 This grate complies with RR-F-621E '200,000lb proof load' test.										
4-bolt iron										
Iron*	99592	19.69" (0.5m)	0.71 x 3.75 avg.	115.5	50.2	Bolt	✗	✗	✓	31.5
Ductile iron to ASTM A 536-84 - minimum grade 65-45-12 This grate complies with RR-F-621E '200,000lb proof load' test. *Supplied with bolts.										

- Key**
- Locking mechanism
 - 200,000lb proof load compliant (Page 128)
 - Compliant with Americans with Disabilities Act of 1990 Section 4.5.4 (Page 140)
 - Bicycle Safe compliant to Australian Standard AS 3996 - 2006 (Page 140)
 - ASME A112.6.3 - 2001 Heel resistant less than 0.31" (8mm) (Page 140)
 - Anti-slip grates - BPN over 24 (Page 140)

Choosing S300K grates

There are three available grate styles to fit the S300K heavy duty channel body.

The conventional slotted grate, with PowerLok™, gives an excellent all-around heavy duty solution with the ease of the PowerLok™ locking/unlocking mechanism. Ideal for use where regular removal of the grate for maintenance is required.

The ADA compliant, longitudinal slotted grate, with PowerLok™, gives the ideal solution to a heavy duty location where some pedestrian access may be required.

Although easy locking and grate removal is important for maintenance, some specific applications require a 4-bolt solution. The four threaded stainless steel inserts in the S300K channel body allow a 4-bolt grate to be bolted into the channel for ultimate stiffness and security. Tamper resistant bolts can also be used.

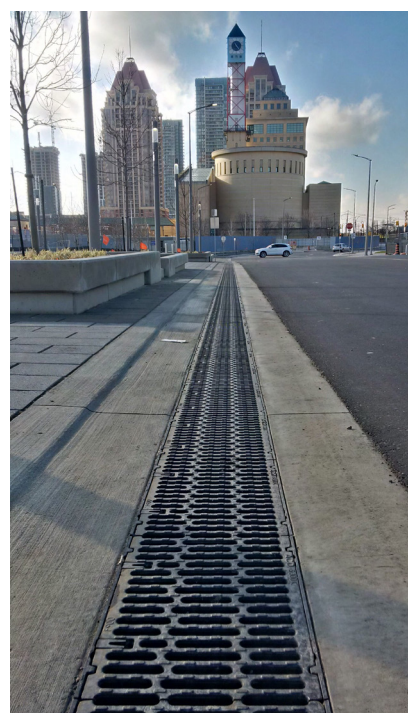

PowerDrain S300K

PowerLok™ - boltless locking system



1

Fit grate

To lock, position side of grate into lugs on rail, place hook part of tool into 'V' and push towards rail.



2

Grate removal

To open PowerLok™, insert tool between rail and PowerLok™ device.



3

Grate removal

Rotate tool 90°, PowerLok™ device should push away from rail.

PowerLok™ - safety clip

For areas of extra security or safety concerns, an optional safety clip is available that provides a visual alert if the PowerLok™ devices are left open. The clip push fits next to the PowerLok™ device and sits level with the grate when the grate is locked. The clip cannot be fitted if the PowerLok™ is open. If all grates are engaged, a run of red dots is visible.

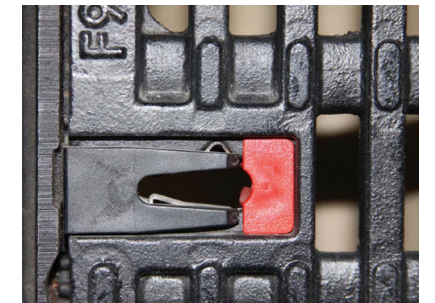

4-Bolt grates



1

Fit grate

Position grate onto channel, align holes in grate with matching holes in edge rail.



2

Fit grate

Using wrench or socket set to tighten. If using a torque wrench, do not set to more than 15 ft. lbs.



3

Grate removal

To remove grates, use wrench or socket set. Carefully store bolts for refitting of grates.

Grate accessories

	Part No.	Weight lbs
PowerLok safety clip (red)	10443	0.1
Replacement bolt for 4-bolt grate	95526	0.1
Tamper resistant bolt for 4-bolt grate	138127	0.1
Tamper resistant bolt drive	138128	0.1



Requires tamper resistant drive bit



Slab Solutions
Trench drains for concrete slabs

SlabDrain	100
MembraneDrain	108
FlowDrain	112

Slab Solutions features

Bolted grates - FG200 grates are lockable with two ½" - 13 x 1½" bolts fixing directly into steel frame at 18" (457mm) intervals.

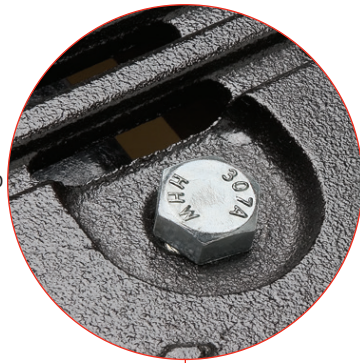

Fiberglass - A lightweight material that is made from polyester resin binder reinforced by glass matting and fibers.

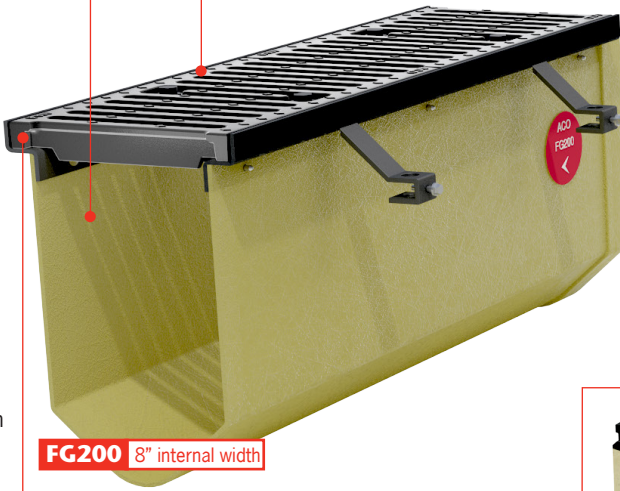

Choice of steel frame - Provides grate support and protects channel edge from damage. Available in black coated, galvanized and stainless steel.



Anti-shunt lugs - Recesses in grate fit around lugs on the edge rail to prevent longitudinal movement.

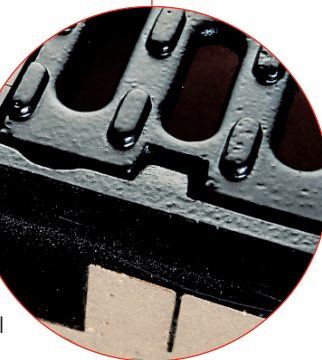

Interconnecting end profiles - Allow easy and effective joining of channels.
SF Sealant Groove - A groove is cast into the ends of every channel. The combined groove this creates allows for a bead of appropriate flexible sealant to be inserted at joints.

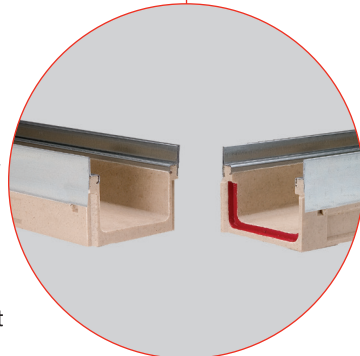

Ductile iron grates - Heavy duty ductile iron grates in choice of Load Class F slotted or longitudinal ADA compliant (H200SK & H300SK ADA grates are rated to Load Class E). A 4-bolt slotted grate is also available.

H100SK/H200SK/H300SK Integrally cast-in ductile iron edge rail - Provides maximum strength and protection for channel body.



Cross Sidewalk Drain - Allows water from a down spout to drain safely, through the SlabDrain, across the sidewalk to the curb.

H100K/H200K/H300K Integrally cast-in galvanized steel edge rail - Provides additional strength and protects channel body from damage. (Stainless steel edge rail also available).

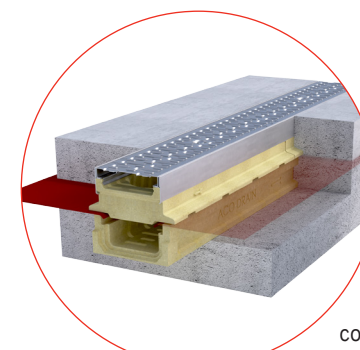

MembraneDrain - For use in a suspended slab where liquid permeating through the pavement is collected on a membrane and directed into the trench drain.



Wide choice of grates - In various materials, styles and slot configurations (including ADA compliant).
H100 - From Load Class A to Load Class C (25 tons).
H100K/H200K/H300K - From Load Class A to Load Class E (60 tons).

H100 Polymer concrete edge - Ideal for situations where metals cannot be used. Product is also used for the base of MembraneDrain.

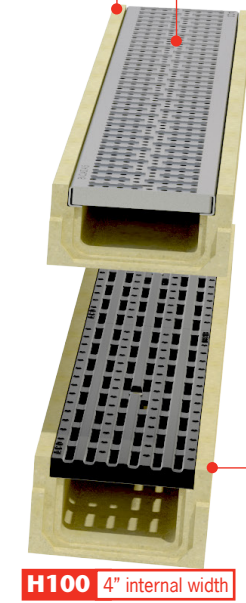

QuickLok™ & DrainLok™ on H100K/H200K/H300K - Patented, boltless locking systems provide quick fitting and removal of grates. Helps reduce installation/maintenance time and cost. H100 will accept QuickLok™ grates only.

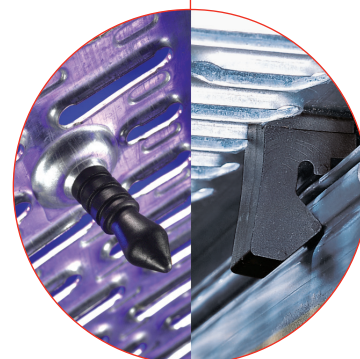

Bottom drill-outs - Included on all constant depth channels to allow vertical evacuation of the system at any point in the run. Drill-outs sized for:
 4" pipes - H100/H100K/H100SK,
 4" & 6" pipes - H200K/H200SK,
 6" & 8" pipes - H300K/H300SK



SlabDrain

Shallow invert trench drain

HK series	102
HSK series	104
H series	106

SlabDrain

Key dimensions

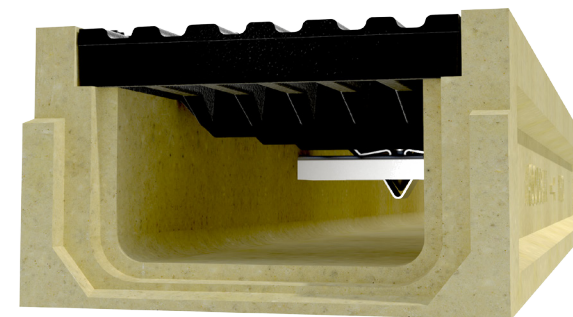
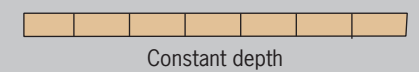
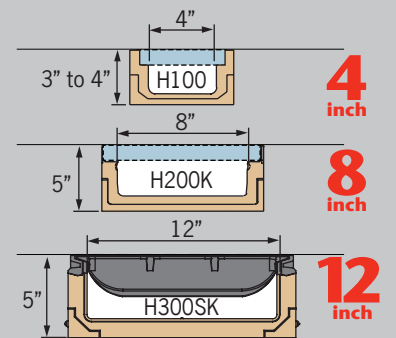

On occasion, installation constraints are of greater concern than hydraulics. The most common constraint is lack of depth. To offer solutions where shallow trench drains are required, SlabDrain is available in 3 edge versions and 3 widths - all constant depth.

Loading varies for each system, depending upon edge rail and grate, up to heavy duty Class F (90 tons) EN 1433. All grates are secured to the channel body by either QuickLok™ or PowerLok™.

Polymer concrete edge rail on H100-8/H100-10 can be used to provide a non-metallic drainage option.



Typical applications

- Restricted depth applications
- Parking decks
- Elevated slabs
- Retro-fit
- Threshold applications

Selection criteria

- Light to heavy industrial duty loads - dependent on type
- Product can be used towards LEED & EPA requirements
- Resistant to many everyday chemicals. *Check page 139*
- Multiple grate options to meet legal requirements
- Multiple grate options to meet design requirements
- Limited hydraulic capacity
- Constant depth channels

ACO DRAIN

System layout

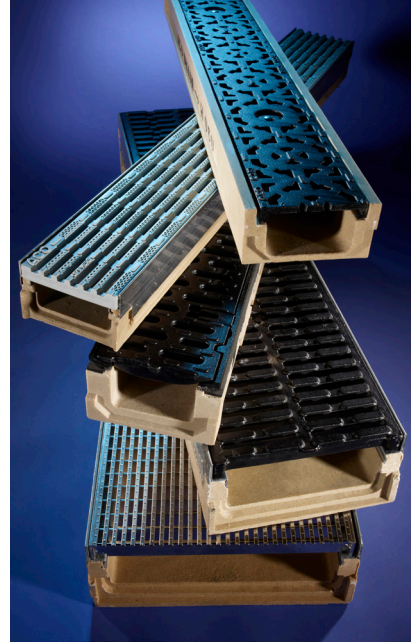
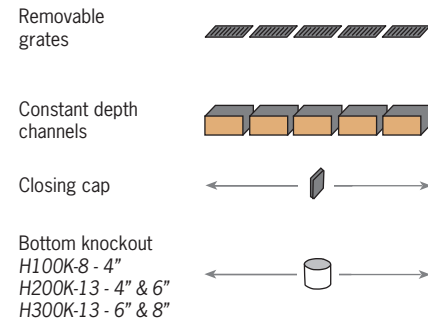

Debris strainer to fit 4" bottom outlets.

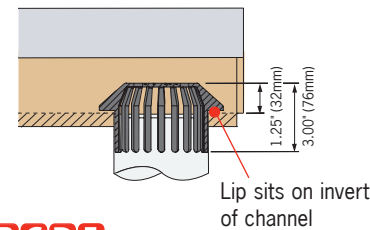

SlabDrain - H100K/H200K/H300K H100KS/H200KS/H300KS

Outlet flow rates

Outlet Product	Size (Sch 40)	Invert in.	GPM	CFS
A Bottom outlet - H100K	4" round	2.56	87	0.20
A Bottom outlet - H200K	4" round	4.00	108	0.24
A Bottom outlet - H300K	6" round	4.00	243	0.54
B Bottom outlet - H200K	6" round	4.00	243	0.54
B Bottom outlet - H300K	8" round	4.00	432	0.96

Note: These are pipe flow rates at specified outlet, NOT channel flow rates.

H100K-8/H100KS-8 channel

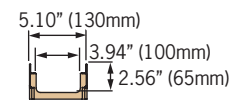
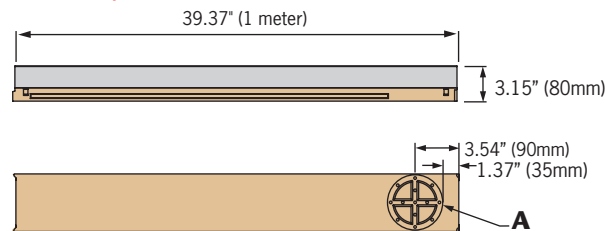

Closing cap

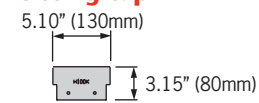

H100K-8/H100KS-8

Parts list

	Part No.		Invert Depth		Overall Depth		Volume	Weight
	H100K-8	H100KS-8	inches	mm	inches	mm	Gallons	lbs
Constant depth channel - 39.37" (1m)	95365	95373	2.56	65	3.15	80	1.2	16.0
Steel closing cap	98462	98471	-	-	3.15	80	-	1.0
Debris strainer for 4" bottom KO	93488	-	-	-	-	-	-	0.2
QuickLok™ locking bar	02899	-	-	-	-	-	-	0.1
Grate removal tool	01318	-	-	-	-	-	-	0.3

Notes:

- H100KS-8 has Grade 304 stainless steel rails and closing cap.
- See pages 30-33 for details on grates - for optimum flow use DrainLok™ grates.

H200K-13/H200KS-13 channel

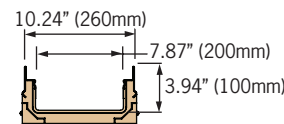
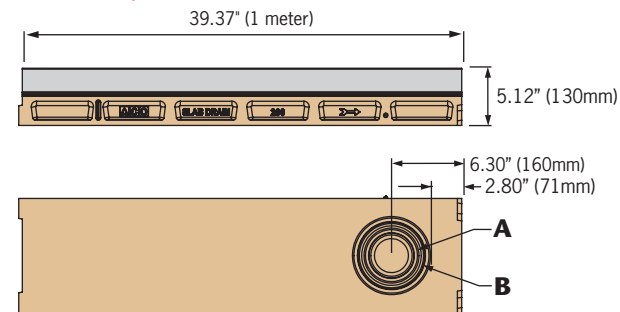

Closing cap

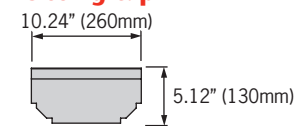

H200K-13/H200KS-13

Parts list

	Part No.		Invert Depth		Overall Depth		Volume	Weight
	H200K-13	H200KS-13	inches	mm	inches	mm	Gallons	lbs
Constant depth channel - 39.37" (1m)	93454	93455	3.94	100	5.12	130	3.7	57.4
Steel closing cap	93458	93459	-	-	5.12	130	-	1.0
Debris strainer for 4" bottom KO	93488	-	-	-	-	-	-	0.2
QuickLok™ locking bar	10457	-	-	-	-	-	-	0.5
Grate removal tool	01318	-	-	-	-	-	-	0.3

Notes:

- H200KS-13 has Grade 304 stainless steel rails and closing cap.
- See pages 42-43 for details on grates - for optimum flow use DrainLok™ grates.

H300K-13/H300KS-13 channel

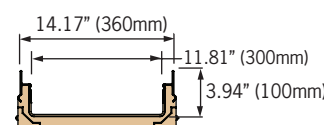
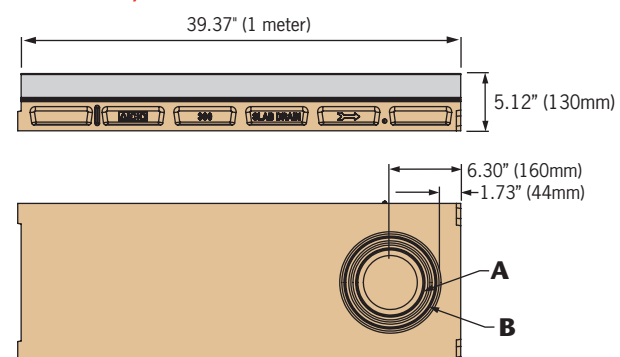

Closing cap

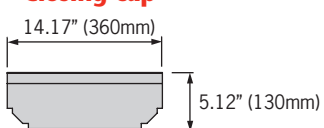

H300K-13/H300KS-13

Parts list

	Part No.		Invert Depth		Overall Depth		Volume	Weight
	H300K-13	H300KS-13	inches	mm	inches	mm	Gallons	lbs
Constant depth channel - 39.37" (1m)	93464	93465	3.94	100	5.12	130	5.5	71.6
Steel closing cap	93468	93469	-	-	5.12	130	-	1.4
QuickLok™ locking bar	10458	-	-	-	-	-	-	0.7
Grate removal tool	01318	-	-	-	-	-	-	0.3

Notes:

- H300KS-13 has Grade 304 stainless steel rails and closing cap.
- See pages 52-53 for details on grates - for optimum flow use DrainLok™ grates.

ACO DRAIN

System layout

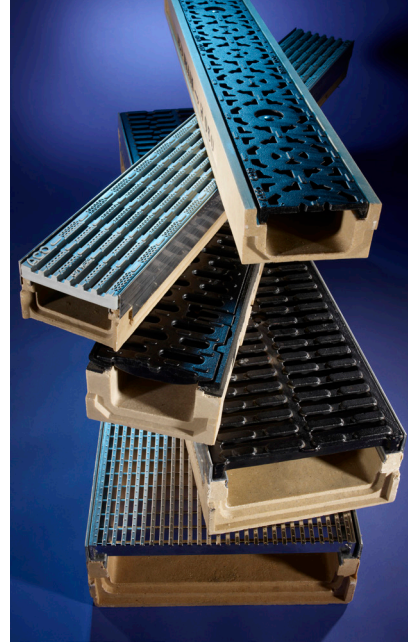
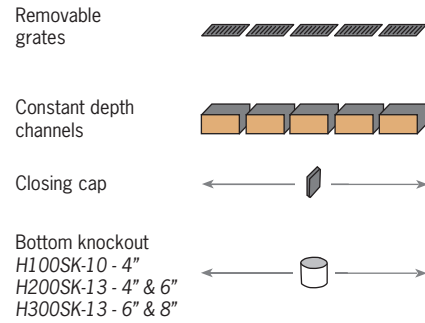

SlabDrain - H100SK/H200SK/H300SK

Outlet flow rates

Outlet Product	Size (Sch 40)	Invert in.	GPM	CFS
A Bottom outlet - H100SK	4" round	2.95	93	0.21
A Bottom outlet - H200SK	4" round	4.00	108	0.24
A Bottom outlet - H300SK	6" round	4.00	243	0.54
B Bottom outlet - H200SK	6" round	4.00	243	0.54
B Bottom outlet - H300SK	8" round	4.00	432	0.96

Note: These are pipe flow rates at specified outlet, NOT channel flow rates.



H100SK-10 channel

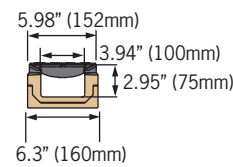
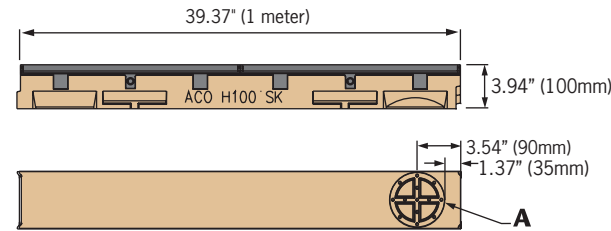

Closing cap

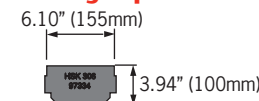

H100SK-10 Parts list

	Part No.	Invert Depth inches	mm	Overall Depth inches	mm	Volume Gallons	Weight lbs
Constant depth channel (no grate) - 39.37" (1m)	93412	2.56	65	3.15	80	1.2	43.5
Load Class F longitudinal grate - 19.69" (0.5m) PowerLok™	96096	-	-	-	-	-	13.6
Load Class F slotted grate - 19.69" (0.5m) PowerLok™	96082	-	-	-	-	-	12.3
Load Class F 4-bolt grate - 19.69" (0.5m)	99590	-	-	-	-	-	10.8
Replacement bolt	95526	-	-	-	-	-	0.1
Tamper resistant bolt for 4-bolt grate	138127	-	-	-	-	-	0.1
PowerLok™ safety clip	10443	-	-	-	-	-	0.1
Steel closing cap	93410	-	-	3.15	80	-	1.0
Debris strainer for 4" bottom knockout	93488	-	-	-	-	-	0.2
Grate removal tool	01318	-	-	-	-	-	0.3

Notes:

- See page 74 for details on grates.
- Debris strainer details for 4" dia. outlet on page 103.

H200SK-13 channel

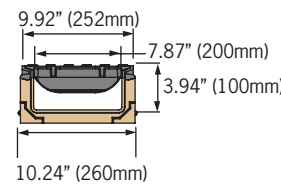
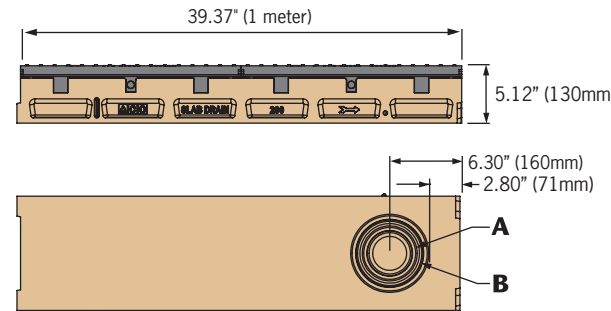

Closing cap

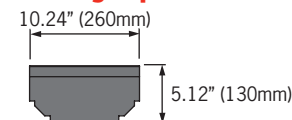

H200SK-13 Parts list

	Part No.	Invert Depth inches	mm	Overall Depth inches	mm	Volume Gallons	Weight lbs
Constant depth channel (no grate) - 39.37" (1m)	63456	3.94	100	5.12	130	3.7	66.4
Load Class E longitudinal grate - 19.69" (0.5m) PowerLok™	72263	-	-	-	-	-	26.4
Load Class F slotted grate - 19.69" (0.5m) PowerLok™	02449	-	-	-	-	-	30.8
Load Class F 4-bolt grate - 19.69" (0.5m)	99591	-	-	-	-	-	26.4
Replacement bolt	95526	-	-	-	-	-	0.1
Tamper resistant bolt for 4-bolt grate	138127	-	-	-	-	-	0.1
PowerLok™ safety clip	10443	-	-	-	-	-	0.1
Steel closing cap	93460	-	-	5.12	130	-	1.0
Debris strainer for 4" bottom knockout	93488	-	-	-	-	-	0.2
Grate removal tool	01318	-	-	-	-	-	0.3

Notes:

- See page 84 for details on grates.
- Debris strainer details for 4" dia. outlet on page 103.

H300SK-13 channel

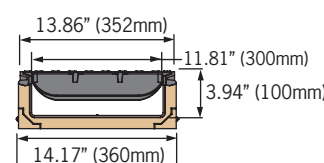
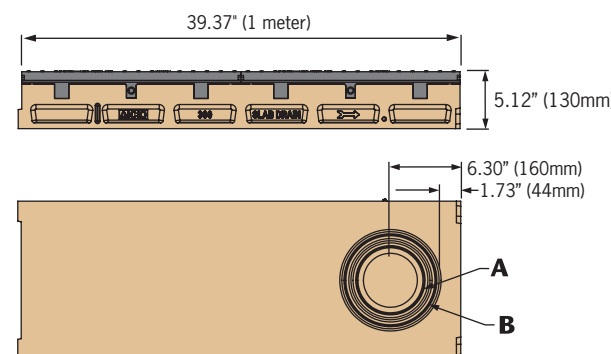

Closing cap

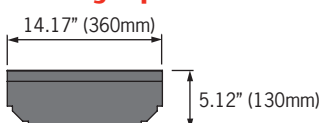

H300SK-13 Parts list

	Part No.	Invert Depth inches	mm	Overall Depth inches	mm	Volume Gallons	Weight lbs
Constant depth channel (no grate) - 39.37" (1m)	63466	3.94	100	5.12	130	5.5	82.2
Load Class E longitudinal grate - 19.69" (0.5m) PowerLok™	96833	-	-	-	-	-	64.0
Load Class F slotted grate - 19.69" (0.5m) PowerLok™	02445	-	-	-	-	-	50.0
Load Class F 4-bolt grate - 19.69" (0.5m)	99592	-	-	-	-	-	50.2
Replacement bolt	95526	-	-	-	-	-	0.1
Tamper resistant bolt for 4-bolt grate	138127	-	-	-	-	-	0.1
PowerLok™ safety clip	10443	-	-	-	-	-	0.1
Steel closing cap	93470	-	-	5.12	130	-	1.4
Grate removal tool	01318	-	-	-	-	-	0.3

Notes:

- See page 94 for details on grates.

ACO DRAIN

System layout

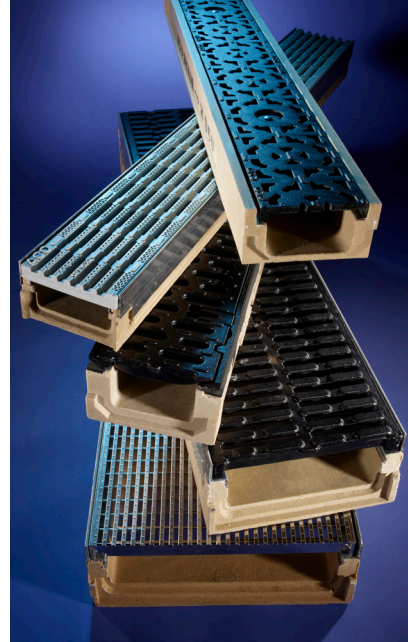
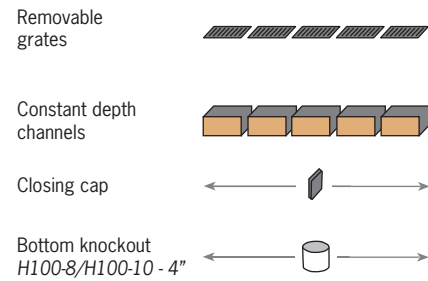

H100-8/10 channel

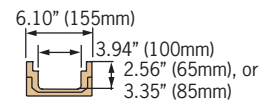
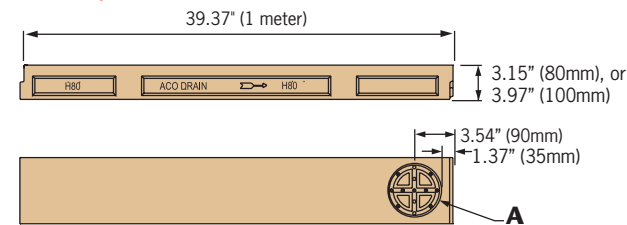

Closing cap

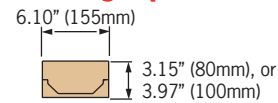

H100-8 & H100-10 Parts list

	Part No.	Invert Depth		Overall Depth		Volume Gallons	Weight lbs
		inches	mm	inches	mm		
H100-8 constant depth channel - 39.37" (1m)	00985	2.56	65	3.15	80	1.16	20.0
H100-10 constant depth channel - 39.37" (1m)	00549	3.35	85	3.95	100	1.70	25.0
H100-8 polymer concrete closing cap	05935	-	-	3.15	80	-	1.0
H100-10 polymer concrete closing cap	05939	-	-	3.95	100	-	1.0
Debris strainer for 4" bottom KO	93488	-	-	-	-	-	0.2
Grate removal tool	01318	-	-	-	-	-	0.3

Notes:

- See page 32 for details on suitable QuickLok™ grates, max. load Class C (56,000lb - 280psi).
 - Use grate removal tool to remove grates (Part #01318).
 - Debris strainer details for 4" dia. outlet on page 103.
- Use with 494Q (97393) or 495Q (97385) grates for non-metallic, non-locking drainage option - see ACO Sport brochure.

Outlet flow rates

Outlet Product	Size (Sch 40)	Invert in.	GPM	CFS
A Bottom outlet - H100-8	4" round	2.56	87	0.20
A Bottom outlet - H100-10	4" round	3.35	99	0.23

Note: These are pipe flow rates at specified outlet, NOT channel flow rates.

SlabDrain - H100/CSD

Cross Sidewalk Drain (CSD)

CSD is a cross sidewalk drainage system which has a polymer concrete curb unit, that is cast into the curb line, to allow water from the H100K-8 or H100KS-8 SlabDrain to discharge into the road. A down spout inlet, also manufactured from polymer concrete, allows rainwater down spouts to drain into the channel.

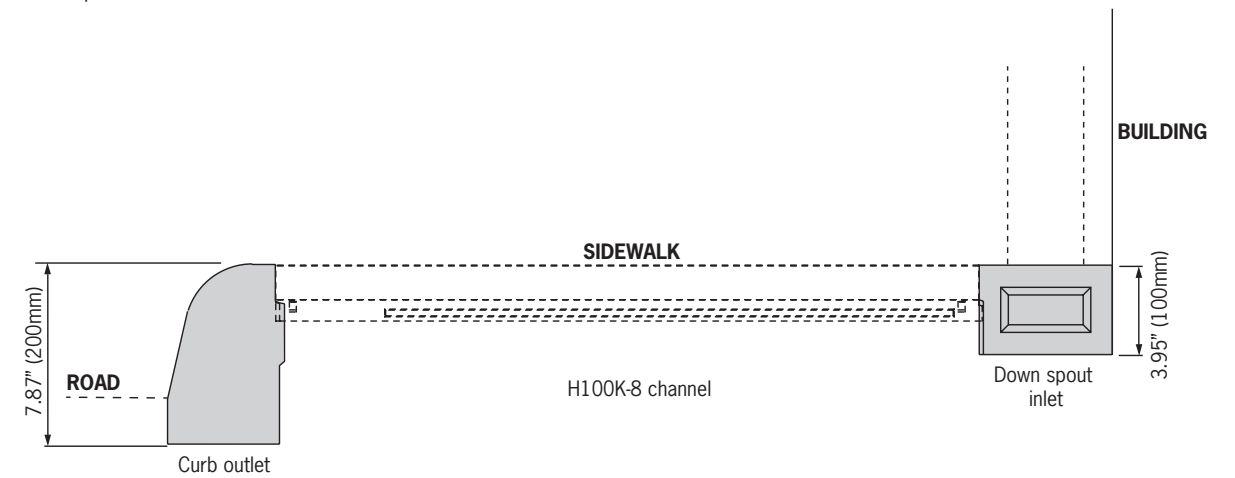

CSD Parts list

	Part No.	Invert Depth		Overall Depth		Weight lbs
		inches	mm	inches	mm	
Curb outlet - type 6 profile	96924	3.5	90	7.87	200	12.7
Down spout inlet	96932	3.2	82	3.95	100	6.0

Notes:

- For use with H100K-8 or H100KS-8 channels only - see page 102-103 for details.

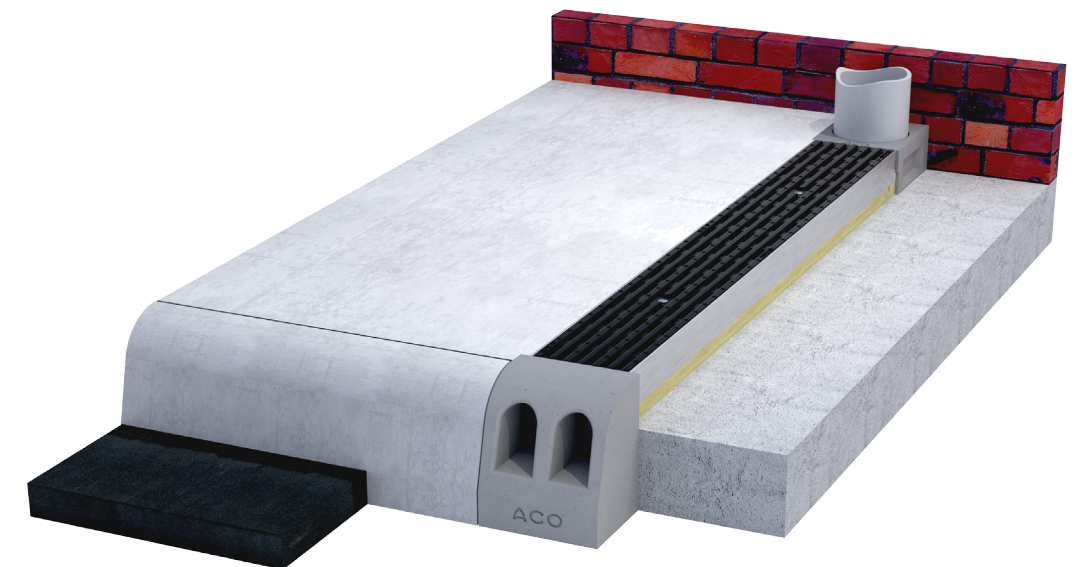



MembraneDrain - External elevated slab drain

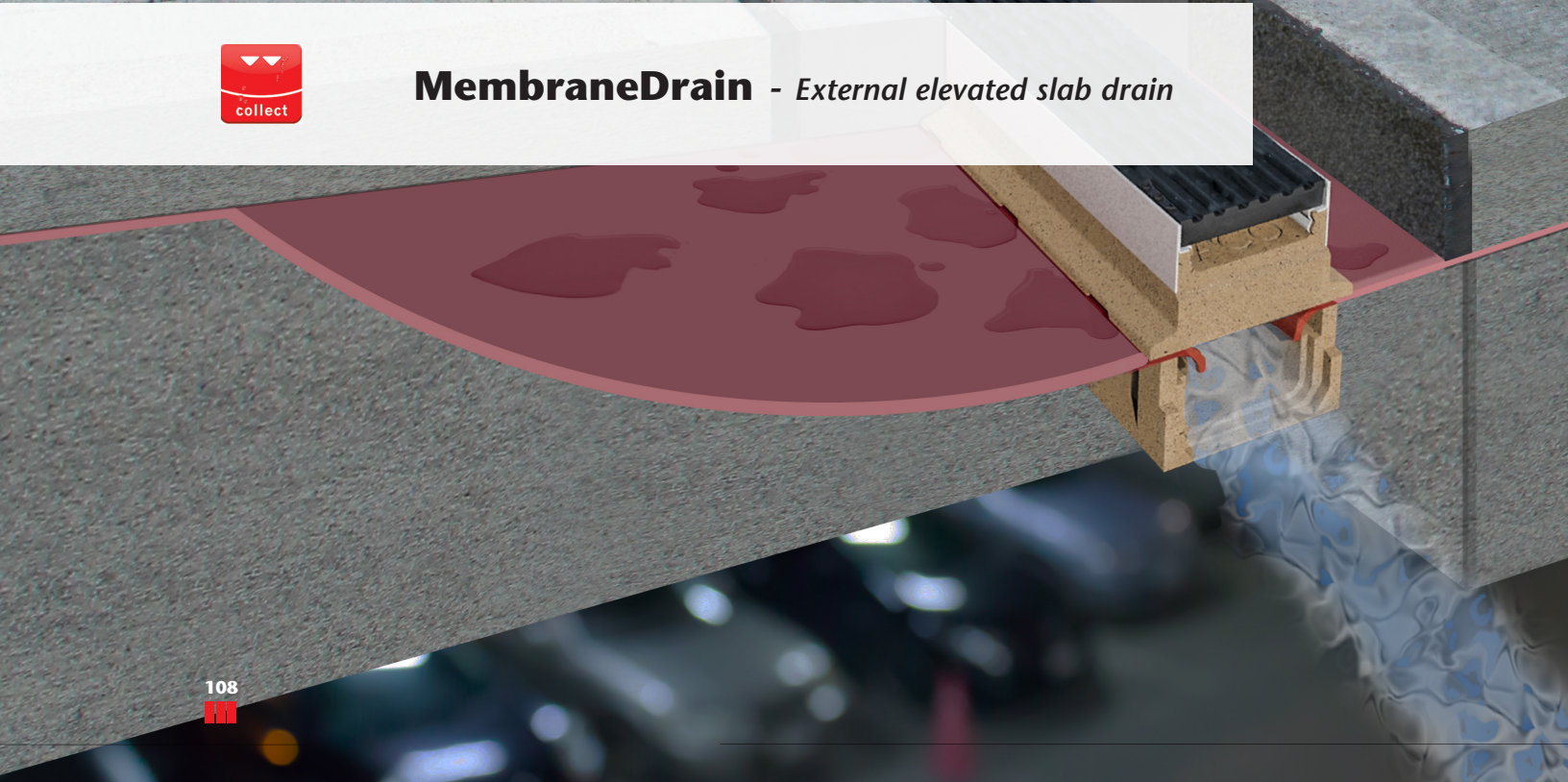

MembraneDrain

Key dimensions

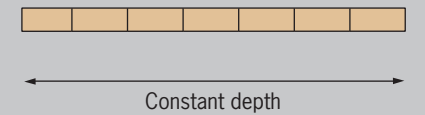
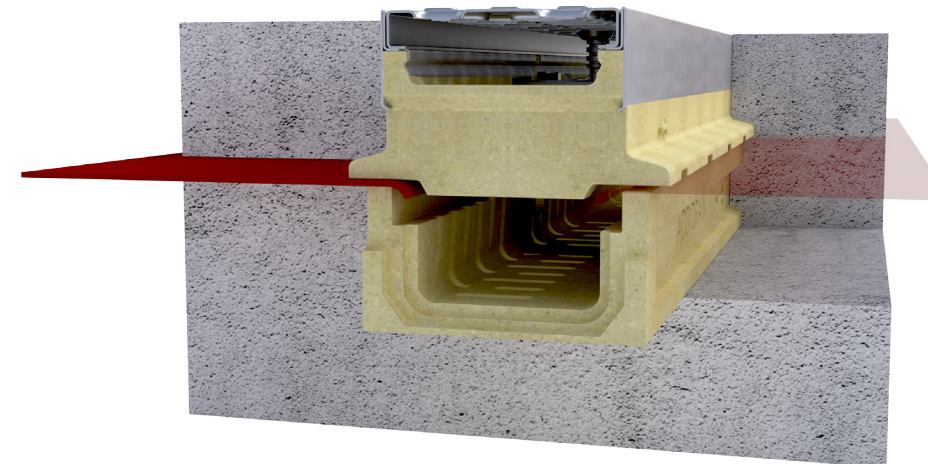
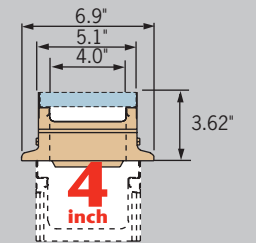

Specifically for use in suspended slab where any liquid permeating through the pavement is collected and directed into the trench drain.

Loading is determined by grate, up to Load Class C (25 ton).

For membrane applications above a habitable area, ACO Building Drainage offers ProfilLine and other suitable products manufactured from stainless steel that are installed entirely above the membrane.

Typical applications

- Rail stations
- Parking garages
- Office buildings
- Airports
- Roof top gardens

Selection criteria



Light to medium duty loads



Product can be used towards LEED & EPA requirements



Resistant to many everyday chemicals. *Check page 139*



Multiple grate options to meet legal requirements



Multiple grate options to meet design requirements



Limited hydraulic capacity



Constant depth channels

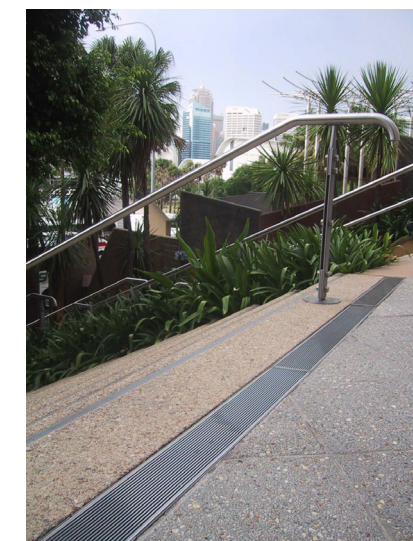

ACO DRAIN

MembraneDrain features

Clamping device - An inverted 'U' shaped locking bar is fitted to the H100-8/H100-10 channel. The locking bar is fitted to the MembraneDrain subframe. Two bolts allow connection between the two bars and hold the membrane tight.

Grates - Sit directly into the MembraneDrain subframe and lock into position with DrainLok™ or QuickLok™.

Membrane - Is clamped between channel and subframe. Maximum membrane of 1/2" (12.7mm) can be accommodated - ensure weep holes are not blocked if using a thick or hot-mopped membrane. Liquids seep through the pavement, collect on the membrane (not supplied by ACO) and drain into channel.

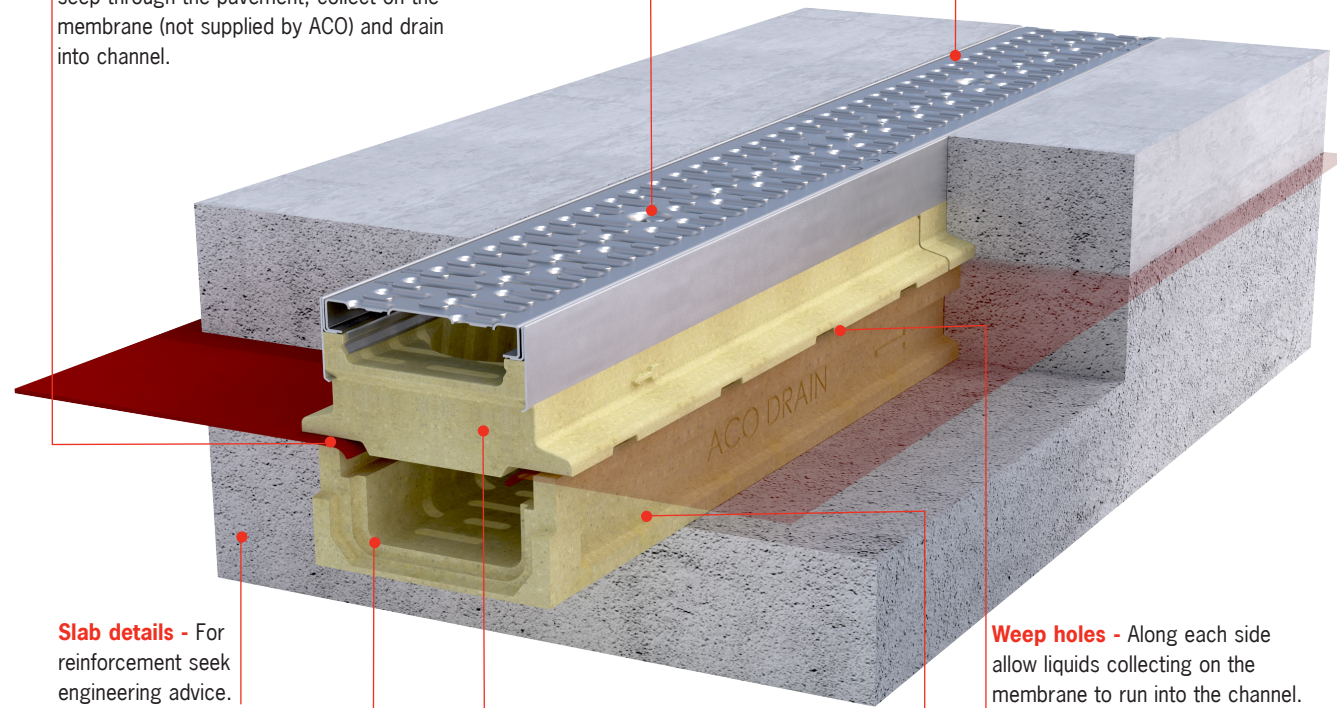

Slab details - For reinforcement seek engineering advice.

Weep holes - Along each side allow liquids collecting on the membrane to run into the channel. Each weep hole opening is 1.18" (30mm) x 0.15" (4mm).

Membrane end cap - Cut down and use top part of K100 closing cap to close end of subframe (Part #96822). See page 28 for details.

End caps and accessories - Are available from the H100-8/H100-10 range. See page 106 for details.

Used with H100-8/H100-10 channel - MembraneDrain subframe fits directly on the H100-8/H100-10 channels. See page 106 for details.

MembraneDrain

MembraneDrain Parts list

Description	Part No.		Invert Depth		Overall Depth		Weight
	Galv.	Stainless	inches	mm	inches	mm	lbs
MembraneDrain subframe - 19.69" (0.5m)	96903	96918	-	-	3.62	92	9.7
MembraneDrain clamping device	96905	96913	-	-	-	-	0.9

Notes:

1. For H100-8/H100-10 channel information see page 106.

Half meter subframe

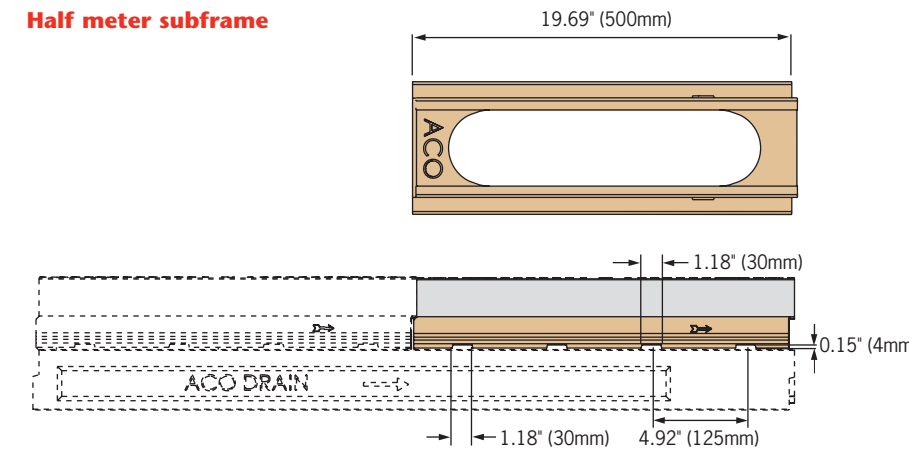

End view

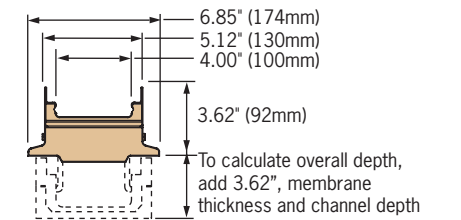

Clamping device

Two assembly screws

Locking bar with QuickLok™ locking mechanism

Inverted U locking bar fits in channel and locks subframe unit and channel together



Membrane collects liquids that seep through surface materials.

Section through MembraneDrain system

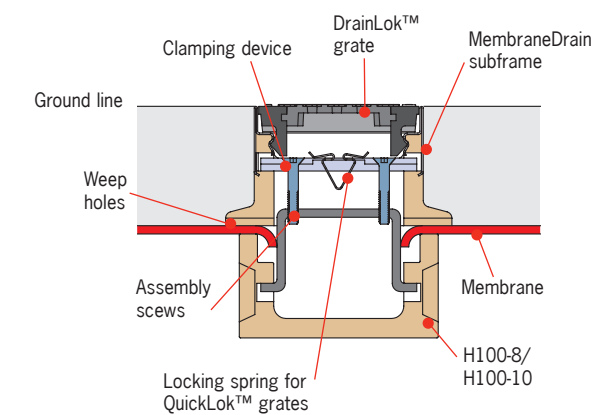

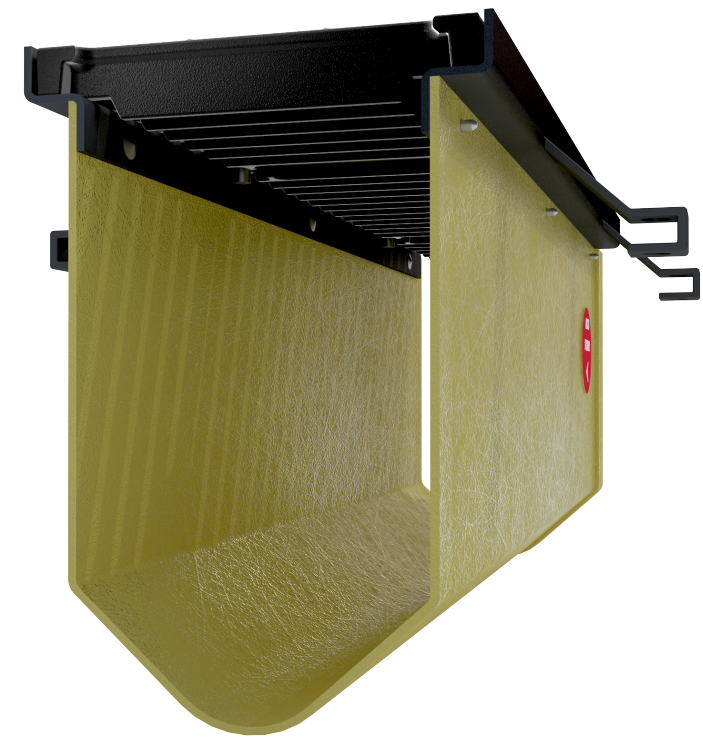

FlowDrain - FG200

Key dimensions

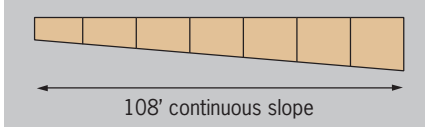
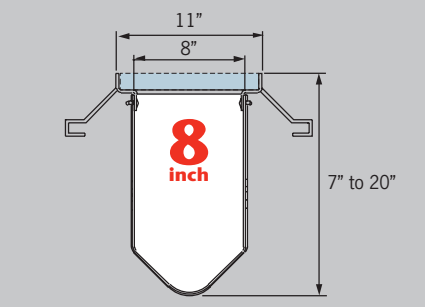







FG200 is an 8" wide fiberglass system with choice of steel slotted Class C (25 ton) or ductile iron Class E (60 ton) grates. Grates are bolted into the steel frame with 2 bolts per 18" section.

Typical applications

- Parking lots & garages
- Airports
- Gas stations
- Industrial areas
- Commercial areas
- Internal applications

Selection criteria

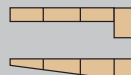
- A B C D E** Light to heavy industrial duty loads 
-  Product can be used towards LEED & EPA requirements
-  Resistant to many everyday chemicals. *Check page 139*
-  Multiple grate options to meet legal requirements
-  Multiple grate options to meet design requirements
-  Increased hydraulic capacity
-  Constant depth and/or sloped depth channels



FlowDrain FG200 - 8" wide fiberglass system

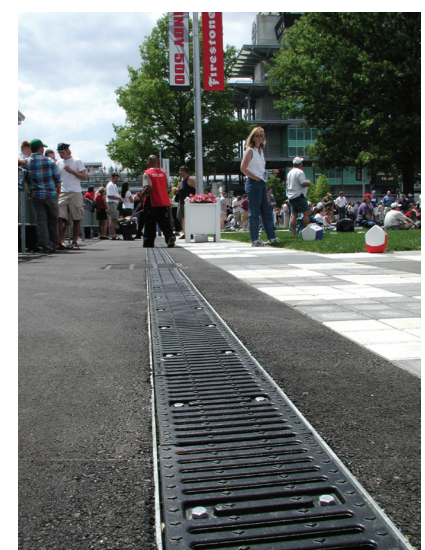

ACO DRAIN
FlowDrain features

FlowDrain - FG200

Bolted grates - FG200 grates are lockable with two 1/2" - 13 x 1 1/2" bolts fixing directly into steel frame at 18" (457mm) intervals.

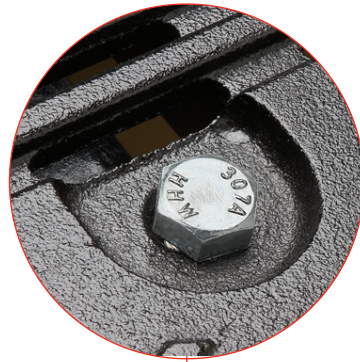

Choice of grates - In various materials and styles (including ADA compliant) for applications up to Load Class E.



Interconnecting end profiles - Allow easy and effective joining of channels. Sealant can be used to create sealed joints.

Bracing blocks - Supplied to brace deeper channels during concrete pour, details on how to position are shown on a sticker on each channel.

FG200 18" internal width

Nelson studs - Attached to frame, act as concrete anchors to secure channels into concrete surround.

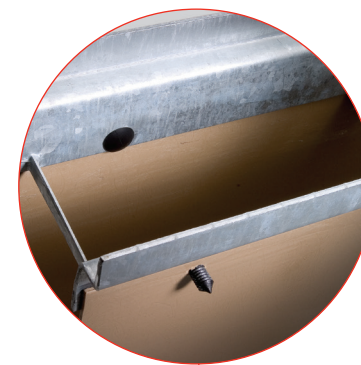

Snap-fit studs - Hold channel body securely to frame and allows quick assembly on-site. Supplied with frame.

Direction arrows - Sticker on side of channel indicates flow direction and ensures channels are installed correctly.

Sloped (1.0%) channel units - 9' (2.75 meter) long units provide 108' (32.9 meter) continuous slope. Equates to 1/8" fall per linear foot. Four constant depth channels extend run lengths. Four 3' (0.915 meter) units and accessories also available.



Installation brackets - Provide simple and easy installation using No. 4 or 5 rebar.



Choice of steel frame - Provides grate support and protects channel edge from damage. Available in black coated, galvanized and stainless steel.

Fiberglass - A lightweight material that is made from polyester resin binder reinforced by glass matting and fibers. See page 136 for material properties.

ACO DRAIN

System layout

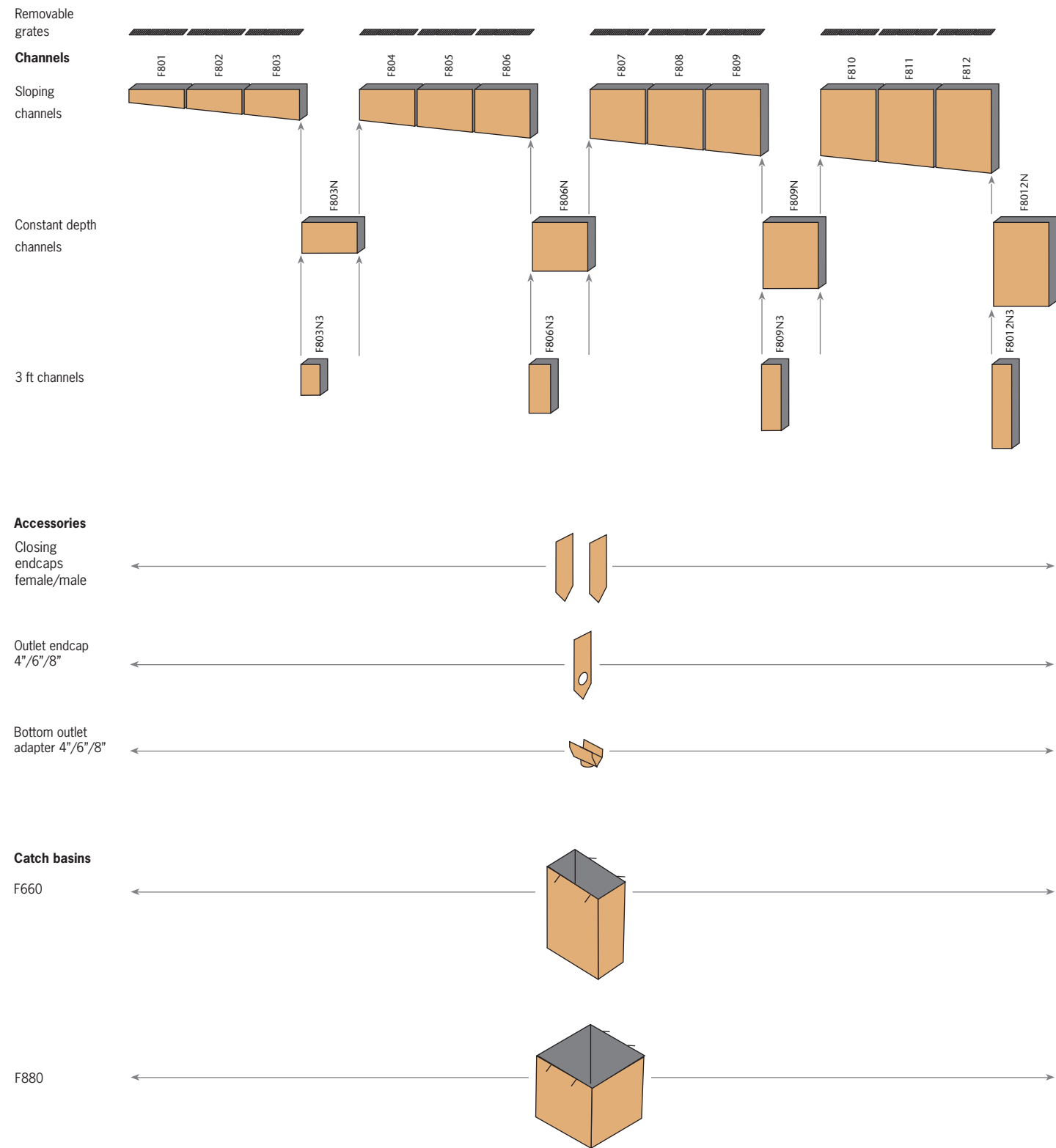

FlowDrain - FG200

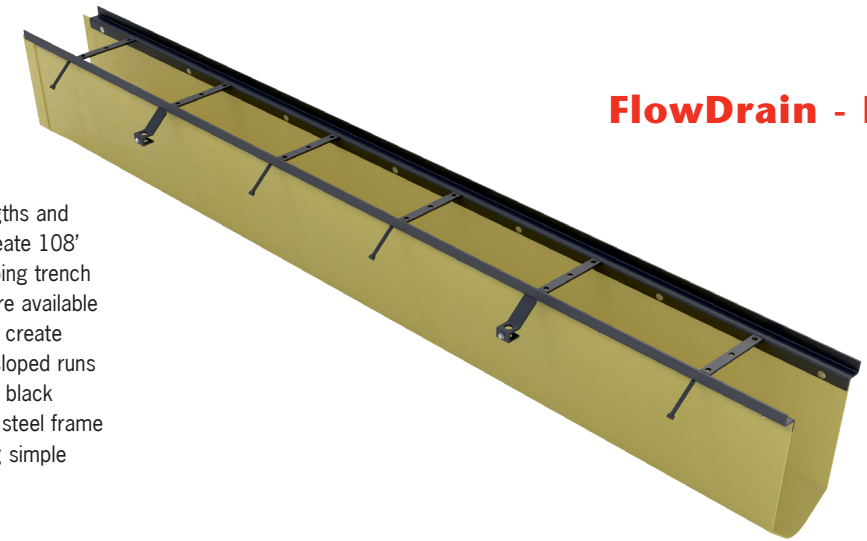

9 ft channels

1.0% sloped channels in 9' lengths and 12 depths which connect to create 108' (32.9 meters) continuously sloping trench run. Constant depth channels are available in 4 depths and can be used to create non-sloped runs or inserted in sloped runs to increase length. Choice of 9' black coated, stainless or galvanized steel frame connects to channel body using simple snap-fit studs.

3 ft channels

Constant depth channels in 4 depths to supplement the 9' channels for easier layouts. Choice of 3' black coated, stainless or galvanized steel frame connects to channel body using simple snap-fit studs.

Male closing cap

Fits outside deep/male end of all channels. Manufactured from polypropylene with choice of black coated, stainless or galvanized steel end rail. Guides aid cutting to correct height. Seal using appropriate flexible sealant.

Female closing cap

Fits inside shallow/female end of channel. Manufactured from polypropylene with choice of black coated, stainless or galvanized steel end frame. Guides aid cutting to correct height. Seal using appropriate flexible sealant.

Outlet cap

Fits outside deep/male end of all channels. Manufactured from polypropylene with choice of black coated, stainless or galvanized steel end rail. Guides aid cutting to correct height. Seal using appropriate flexible sealant. Bell end connection to fit 4", 6" or 8" Schedule 40 pipes.

Vertical outlet adapter

4", 6" or 8" Schedule 40 vertical outlet adapter manufactured from polypropylene.

Can be secured to underside of channel using appropriate flexible sealant to provide vertical bell end for easy attachment to 4", 6" or 8" Schedule 40 pipe. Can be used anywhere along channel.

Note: For depth 801-804 channels ACO recommends removal of unused sections of the bell end to ensure adequate pavement material coverage.

F660 & F880 catch basins

One piece fiberglass catch basins with choice of black coated, stainless or galvanized steel frame, lockable steel bar or ductile iron slotted grate and plastic trash bucket.

Accessories include 4", 6" and 8" Schedule 40 pipe adapters and channel collars to connect channel to catch basin.

See page 121 for details.



FlowDrain - FG200

9 ft channel

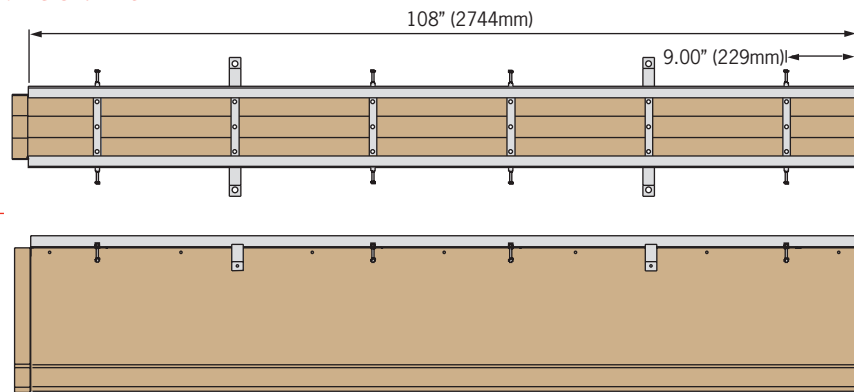

3 ft channel

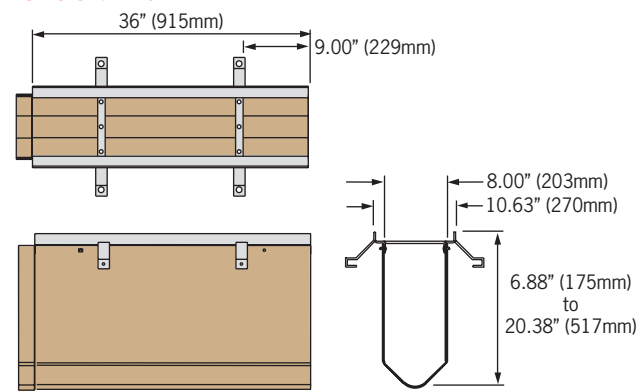

Outlet flow rates

Channels				
Outlet	Size (Sch 40)	Invert in.	GPM	CFS
A	4" round	7.88	154	0.34
A	4" round	20.25	246	0.54
B	6" round	7.88	346	0.77
B	6" round	20.25	553	1.23
C	8" round	7.88	616	1.37
C	8" round	20.25	982	2.18
D	4" round	9.00	145	0.33
D	4" round	20.25	233	0.54
E	6" round	10.13	330	0.76
E	6" round	20.25	510	1.17
F	8" round	12.38	635	1.46
F	8" round	20.25	880	2.03

Catch basins		F660			F880		
Outlet	Size (Sch 40)	Invert in.	GPM	CFS	Invert in.	GPM	CFS
G	4" round	26.50	269	0.60	27.50	275	0.61
H	6" round	26.50	594	1.32	27.50	606	1.35
I	8" round	26.50	1032	2.30	27.50	1055	2.35

Note: These are pipe flow rates at specified outlet, NOT channel flow rates. Catch Basin flow rates without trash bucket - using trash bucket reduces flow.

Closing cap (Female)

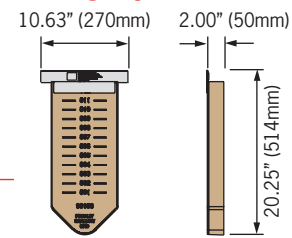

Closing cap (Male)

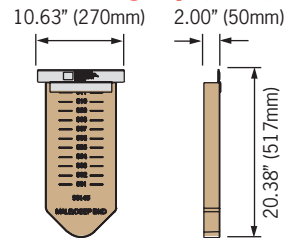

Outlet end cap

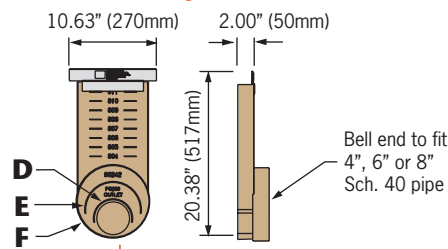

Vertical outlet adapter

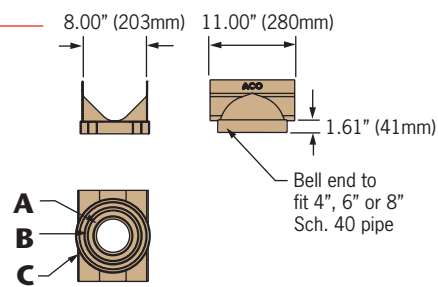

FF660 Catch Basin

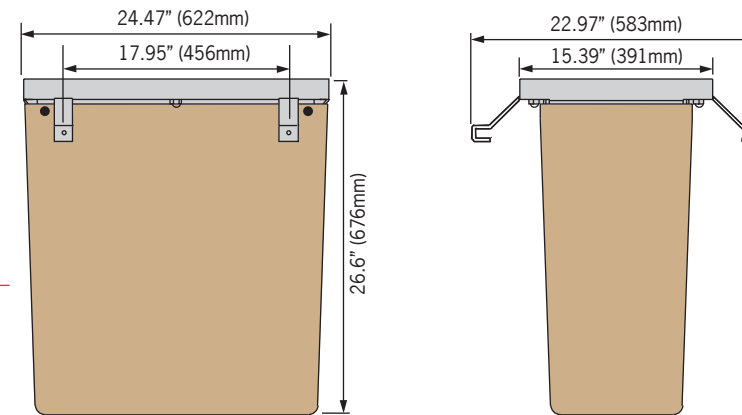

FF880 Catch Basin

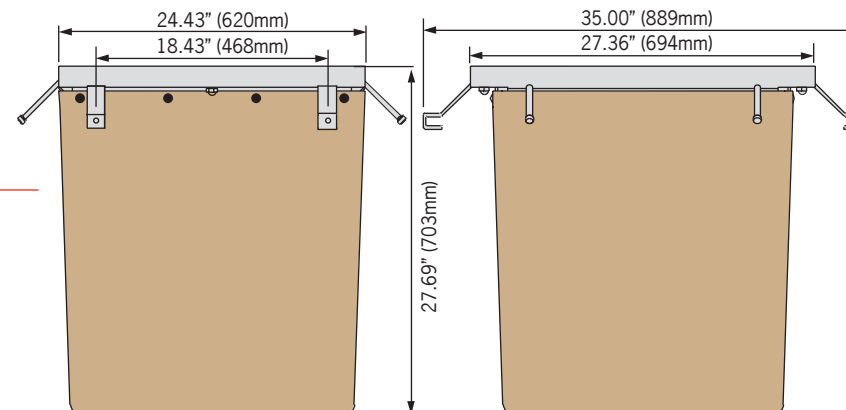

Pipe adapter

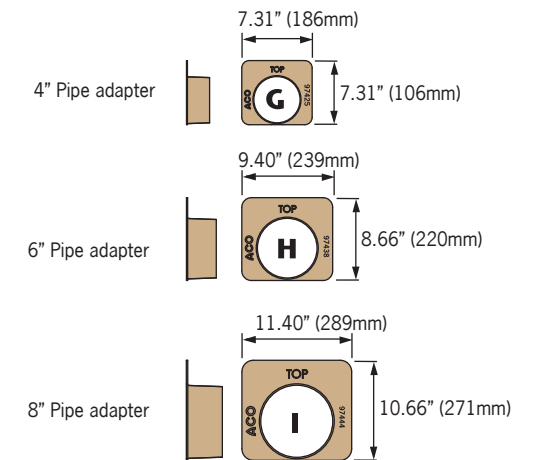

Channel collar

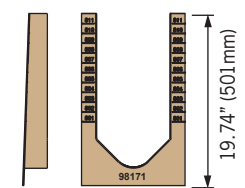

ACO DRAIN

FG200 Parts table

	Part No.	Invert Depth				Overall Depth				Vol Gal	Wgt lbs
		Inches		mm		Inches		mm			
		female	male	female	male	female	male	female	male		
F801 Sloped channel - 108" (2.75m)	99006	6.75	7.88	172	200	6.88	8.01	175	203	18.37	11.0
F802 Sloped channel - 108" (2.75m)	99013	7.88	9.00	200	229	8.01	9.13	203	232	22.58	12.0
F803 Sloped channel - 108" (2.75m)	99021	9.00	10.13	229	257	9.13	10.26	232	260	26.79	13.0
F803N Constant depth channel - 108" (2.75m)	99048	10.13	10.13	257	257	10.26	10.26	260	260	28.80	15.5
F803N3 Constant depth channel - 36" (0.915m)	99034	10.13	10.13	257	257	10.26	10.26	260	260	9.60	5.2
F804 Sloped channel - 108" (2.75m)	99055	10.13	11.25	257	286	10.26	11.38	260	289	31.00	14.1
F805 Sloped channel - 108" (2.75m)	99062	11.25	12.38	286	314	11.38	12.51	289	318	35.21	15.2
F806 Sloped channel - 108" (2.75m)	99071	12.38	13.50	314	343	12.51	13.63	318	346	39.42	16.3
F806N Constant depth channel - 108" (2.75m)	99095	13.50	13.50	343	343	13.63	13.63	346	346	41.50	16.3
F806N3 Constant depth channel - 36" (0.915m)	99084	13.50	13.50	343	343	13.63	13.63	346	346	13.83	5.5
F807 Sloped channel - 108" (2.75m)	99109	13.50	14.63	343	371	12.63	14.76	346	375	43.63	17.4
F808 Sloped channel - 108" (2.75m)	99116	14.63	15.75	371	400	14.76	15.88	375	403	47.84	18.5
F809 Sloped channel - 108" (2.75m)	99123	15.75	16.87	400	429	15.88	17.00	403	432	52.05	19.6
F809N Constant depth channel - 108" (2.75m)	99145	16.87	16.87	429	429	17.00	17.00	432	432	54.10	19.6
F809N3 Constant depth channel - 36" (0.915m)	99132	16.87	16.87	429	429	17.00	17.00	432	432	18.00	6.5
F810 Sloped channel - 108" (2.75m)	99156	16.87	18.00	429	457	17.00	18.13	432	460	56.26	20.7
F811 Sloped channel - 108" (2.75m)	99162	18.00	19.13	457	486	18.13	19.26	460	489	60.47	21.8
F812 Sloped channel - 108" (2.75m)	99175	19.13	20.25	486	514	19.26	20.38	489	518	64.68	23.0
F812N Constant depth channel - 108" (2.75m)	99192	20.25	20.25	514	514	20.38	20.38	518	518	66.76	23.0
F812N3 Constant depth channel - 36" (0.915m)	99186	20.25	20.25	514	514	20.38	20.38	518	518	22.25	7.7
Black coated steel frame - 108" (2.75m)	97066	-	-	-	-	-	-	-	-	-	57.9
Black coated steel frame - 36" (0.915m)	98524	-	-	-	-	-	-	-	-	-	19.3
Galvanized steel frame - 108" (2.75m)	97079	-	-	-	-	-	-	-	-	-	57.9
Galvanized steel frame - 36" (0.915m)	98538	-	-	-	-	-	-	-	-	-	19.3
Stainless steel frame - 108" (2.75m)*	97087	-	-	-	-	-	-	-	-	-	57.9
Stainless steel frame - 36" (0.915m)*	98545	-	-	-	-	-	-	-	-	-	19.3
Closing cap (female) with black end frame	98365	-	-	-	-	20.38	20.38	518	518	-	1.1
Closing cap (female) with galv. steel end frame	98386	-	-	-	-	20.38	20.38	518	518	-	1.1
Closing cap (female) with S/S end frame	98375	-	-	-	-	20.38	20.38	518	518	-	1.1
Closing cap (male) with black end frame	98363	-	-	-	-	20.38	20.38	518	518	-	1.3
Closing cap (male) with galv. steel end frame	98382	-	-	-	-	20.38	20.38	518	518	-	1.3
Closing cap (male) with S/S end frame	98372	-	-	-	-	20.38	20.38	518	518	-	1.3
Outlet cap (male) with black end frame	98361	20.25	20.25	514	514	20.38	20.38	518	518	-	1.8
Outlet cap (male) with galv. steel end frame	98381	20.25	20.25	514	514	20.38	20.38	518	518	-	1.8
Outlet cap (male) with S/S end frame	98373	20.25	20.25	514	514	20.38	20.38	518	518	-	1.8
Vertical outlet adapter - 4", 6" or 8" outlet	98103	20.25	20.25	514	514	20.38	20.38	518	518	-	1.6

Notes:

- Invert depths are for the channel body & frame assembled.
 - Channel weights are for fiberglass body only.
 - Closing/Outlet caps can be cut down to suit all channels.
 - Add 2" to length of each channel for female joining flange (only applicable at shallowest end of trench run).
 - Frames supplied with plastic snap-fit studs for connecting to fiberglass body.
 - See page 122 for grate details.
- * Grade 304 stainless steel frames, ACO recommends the use of non-galvanized grates with stainless steel frames to avoid galvanic corrosion.

FlowDrain - FG200

Fiberglass catch basins

Fiberglass catch basins are available with a variety of frames and grates. Channel collars are available to connect all depths of channel on any side of the catch basin. Pipe adapters are available to allow inlet/outlet pipe connections at any position on the catch basin.

F660 catch basin

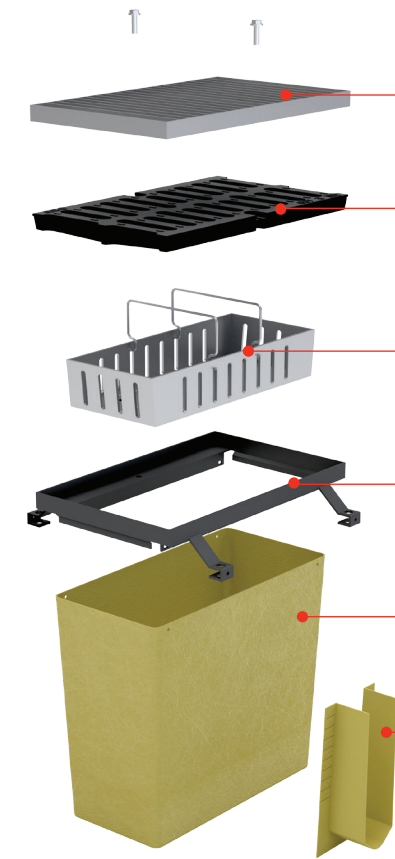

Grates - a choice of galvanized or stainless steel bar or slotted ductile iron grates, locked in place with 2 bolts. See page 123.

Trash bucket - plastic trash bucket designed to collect debris that has collected in the trench and washed into the catch basin.

Frame - coated black, galvanized or stainless steel frame attached to catch basin body with snap-fit studs.

Catch basin body - fiberglass body in choice of 2 sizes.

Channel collar - adapter to enable smooth transition of any depth FG200 channel on any side. Can be cut to correct height.

Pipe adapter - plain end adapter to allow inlet or outlet pipes to be easily attached to the outer wall of catch basin at any position. Available for 4", 6" and 8" Schedule 40 pipes.

F880 catch basin

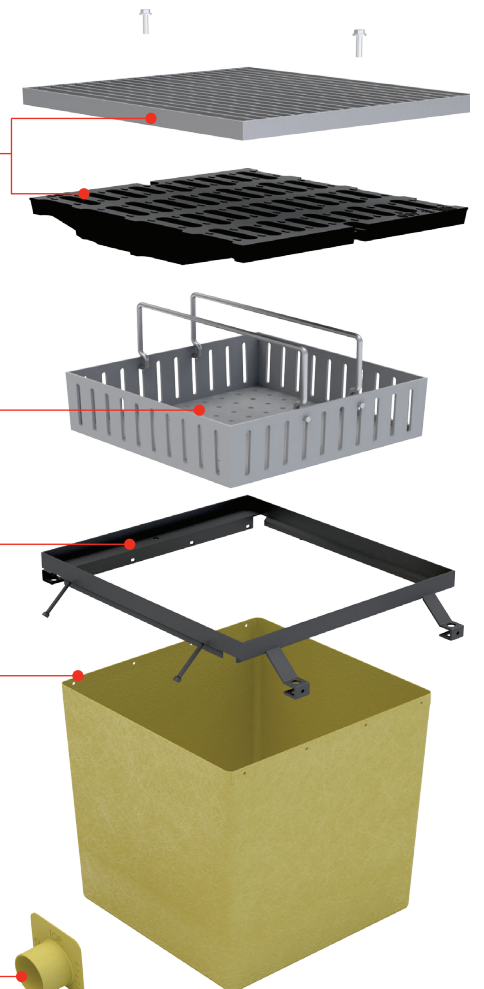

Parts table - FG200 Catch basins	Part No.	Volume Gallons	Weight lbs
F660 catch basin - 24" x 12"	98069	27.00	22.0
F660 black coated steel frame	97995	-	13.8
F660 galvanized steel frame	98008	-	14.4
F660 stainless steel frame*	98013	-	14.4
F660 plastic trash bucket	98067	-	5.0
F880 catch basin - 24" x 24"	98075	55.00	22.0
F880 black coated steel frame	98021	-	23.2
F880 galvanized steel frame	98034	-	24.2
F880 stainless steel frame*	98048	-	24.2
F880 plastic trash bucket	98059	-	8.4
FG200 channel/catch basin adapter	98171	-	1.1
4" pipe plain end adapter	97425	-	0.4
6" pipe plain end adapter	97438	-	0.6
8" pipe plain end adapter	97444	-	0.9

* Grade 304 stainless steel frames.
ACO recommends use of non-galvanized grates with stainless steel frames to avoid galvanic corrosion.

Available FG200 grates

Description	Part No.	Length inches (m)	Slot Size inches	Intake area sq. in.	Wgt lbs	Locking mechanism	Compliant with Americans with Disabilities Act of 1990 Section 4.5.4 (Page 140)	Heel safe equal or less than 0.25" (6.5mm) (Page 140)	Bicycle Safe compliant to Australian Standard AS 3996 - 2006 (Page 140)	ASME A112.6.3 - 2001 Heel resistant less than 0.31" (8mm) (Page 140)	Anti-slip grates - BPN over 24 (Page 140)	200,000lb proof load compliant (Page 128)
C Load Class C - 56,000lbs - EN 1433 968psi Commercial vehicle												
Bar steel												
Galvanized ¹	93899	36" (0.9m)	1.0 x 3.6	264.0	28.6	Bolt	×	×	×	✓		54.3
Stainless* ²	93891	36" (0.9m)				61.0						
* Grade 304 stainless steel.												
E Load Class E - 135,000lbs - EN1433 2,321psi Industrial												
Slotted iron												
Iron ³	93896	18" (0.45m)	0.61 x 7.87	58.7	25.2	Bolt	×	×	×	×		29.0
Ductile iron to ASTM A 536-84 - minimum grade 64-45-12. This grate complies with RR-F-621E '200,000lb proof load' test.												
Longitudinal iron												
Iron ³	93893	18" (0.45m)	1.75 x 0.25	35.0	28.2	Bolt	✓	✓	✓	✓		31.9
Ductile iron to ASTM A 536-84 - minimum grade 64-45-12. This grate complies with RR-F-621E '200,000lb proof load' test.												

- Notes:**
- Supplied with 4 galvanized steel socket head bolts (1/2" - 13 x 1 1/2") - replacement part 93895.
 - Supplied with 4 stainless steel socket head bolts (1/2" - 13 x 1 1/2") - replacement part 93897.
 - Supplied with 2 stainless steel hex head bolts (1/2" - 13 x 1 1/2") - replacement part 93892.

Key

- Locking mechanism
- Heel safe equal or less than 0.25" (6.5mm) (Page 140)
- 200,000lb proof load compliant (Page 128)
- Compliant with Americans with Disabilities Act of 1990 Section 4.5.4 (Page 140)
- Bicycle Safe compliant to Australian Standard AS 3996 - 2006 (Page 140)
- ASME A112.6.3 - 2001 Heel resistant less than 0.31" (8mm) (Page 140)
- Anti-slip grates - BPN over 24 (Page 140)

Bolted grates

Bolted FG200 grates offer mechanical, secure fixing of grates into the channel frame. Two bolts per 18" grate section lock into cross bars in the steel frame. Care must be taken to ensure that all bolts are secure and are not overtightened which can damage the frame.



1

Fit grate

Position grate onto channel, align holes in grate with matching holes in frame cross bar.

2

Grate removal

Using wrench or socket set to tighten. If using a torque wrench do not set to more than 15 ft. lbs.

3

Grate removal

To remove grates use wrench or socket set. Carefully store bolts for refitting of grates.

Available F660 grates

Description	Part No.	Length inches (m)	Slot Size inches	Intake area sq. in.	Wgt lbs	Locking mechanism	Compliant with Americans with Disabilities Act of 1990 Section 4.5.4 (Page 140)	Heel safe equal or less than 0.25" (6.5mm) (Page 140)	Bicycle Safe compliant to Australian Standard AS 3996 - 2006 (Page 140)	ASME A112.6.3 - 2001 Heel resistant less than 0.31" (8mm) (Page 140)	Anti-slip grates - BPN over 24 (Page 140)	200,000lb proof load compliant (Page 128)
C Load Class C - 56,000lbs - EN 1433 739psi Commercial vehicle												
Bar steel												
Galvanized ¹	97443	24" (0.6m)	1.0 x 3.3	267.0	35.2	Bolt	×	×	×	✓		54.3
Stainless* ²	97442	24" (0.6m)				61.0						
* Grade 304 stainless steel.												
E Load Class E - 135,000lbs - EN1433 1,773psi Industrial												
Slotted iron												
Iron ³	97449	24" (0.6m)	1.2 x 6.1 avg	130.0	75.0	Bolt	×	×	×	✓		31.0
Ductile iron to ASTM A 536-84 - minimum grade 64-45-12												

Available F880 grates

Description	Part No.	Length inches (m)	Slot Size inches	Intake area sq. in.	Wgt lbs	Locking mechanism	Compliant with Americans with Disabilities Act of 1990 Section 4.5.4 (Page 140)	Heel safe equal or less than 0.25" (6.5mm) (Page 140)	Bicycle Safe compliant to Australian Standard AS 3996 - 2006 (Page 140)	ASME A112.6.3 - 2001 Heel resistant less than 0.31" (8mm) (Page 140)	Anti-slip grates - BPN over 24 (Page 140)	200,000lb proof load compliant (Page 128)
C Load Class C - 56,000lbs - EN 1433 739psi Commercial vehicle												
Bar steel												
Galvanized ¹	97452	24" (0.6m)	1.0 x 3.3	456.0	63.8	Bolt	×	×	×	✓		54.3
Stainless* ²	97455	24" (0.6m)				61.0						
* Grade 304 stainless steel.												
E Load Class E - 135,000lbs - EN1433 1,773psi Industrial												
Slotted iron												
Iron ³	97453	24" (0.6m)	1.2 x 5.5	226.0	206.0	Bolt	×	×	×	✓		23.8
Ductile iron to ASTM A 536-84 - minimum grade 64-45-12												

- Notes:**
- Supplied with 2 galvanized steel socket head bolts (1/2" - 13 x 1 1/2") - replacement part 93895.
 - Supplied with 2 stainless steel socket head bolts (1/2" - 13 x 1 1/2") - replacement part 93897.
 - Supplied with 2 stainless steel hex head bolts (1/2" - 13 x 1 1/2") - replacement part 93892.



ACO has an established Technical Services Department with engineers and support staff offering many years experience advising on surface water management.

These free services are offered with no obligation and are supported with extensive, high quality information, literature and project specific technical documentation.

Technical support falls into four areas:

- 1** Application126
 - Installed location factors - loading, site & user requirements
- 2** Hydraulics142
 - Amount of liquid to collect and drain
- 3** Trench layout148
 - Where to position trench drain & outlets
- 4** Installation support150
 - Correct installation for long service life



Design services & support

1 Application

Trench drains are designed to collect and remove surface water. Failure is usually due to application issues. If the product 'physically' fails, replacement is essential. The priority is to address where and how the product will be used to ensure long service life.

1a) Loading



Loads influence pavement design and as the trench system is an integral part of the pavement, the correct installation detail is critical to product longevity.

A summary and comparison of commonly referenced Load Standards is provided on pages 128-129.



Installation details

SERVICE A - ACO can supply:

- Advice on application load class
- Load test certificates
- Installation section details

1b) Site requirements



There are a variety of materials used in trench drain systems. A summary of each is provided on pages 136-137.

Each material behaves differently in various environments and situations. ACO can provide advice on chemical and corrosion resistance for most common trench drain materials.



Non-metallic and environmental (SD, LID, LEED) considerations may also impact product choices. ACO can assist in these decisions as well.

Material data

SERVICE B/C - ACO can supply:

- Material coupons (samples) for on site testing
- Material test reports

1c) User requirements



ACO provides specific product documentation indicating the standards each complies with.



Supporting documentation

SERVICE D - ACO can supply:

- Industry standards/requirements and 3rd party test data, where relevant

2 Hydraulics

Hydraulics covers trench drain functionality and failure isn't always apparent. Use of an undersized or oversized trench drain can have major cost and liability consequences, particularly in applications where flood damage to property or personal risk are of concern.

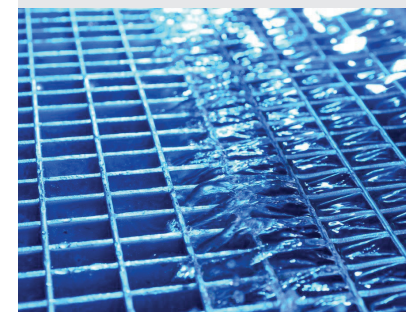

ACO offers several project specific hydraulic support services to accurately determine the most hydraulically efficient and cost effective trench drain size and layout.

Trench hydraulics - Hydro

SERVICE E - ACO can supply:

- Hydraulic liquid profiles for individual trench runs
- Liquid depth profiles at design conditions

Trench hydraulics - Ponding

SERVICE F - ACO can supply:

- Map of temporary ponding
- Approximate duration of any temporary ponding

Grate hydraulics - GIC

SERVICE G - ACO can supply:

- Grate performance dependent on location with crossfalls

3 Trench layout

Modular trench runs can be complex and ensuring the correct materials can be time consuming, particularly where multiple trench runs are involved. In addition, once materials arrive on site, determining what pieces go where can be a challenge. ACO offers several services to ensure this part of the process runs as smoothly and efficiently as possible.



Trench layout documents

SERVICE H - ACO can supply:

- Plan layouts of trench runs (CAD)
- Section layouts of trench runs showing modular sequence of channel units
- Bill of Materials (BOM) - fully itemizing parts and pieces

4 Installation support

Even the right product can fail if incorrectly installed. Therefore, to ensure your trench drain investment performs as expected, getting the installation right is important. ACO has an in-house team of engineers qualified to offer advice on most installation issues, such as size of concrete surround, haunch details, installation method options, etc.

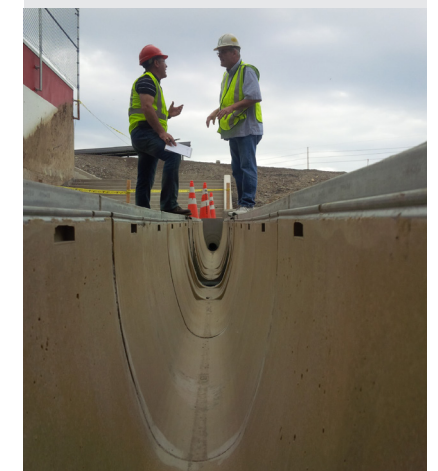

Installation guidance

ACO can supply:

- Installation section details by product type, pavement type and loading type
- Consultation on specific installation concerns



1a) Application - Loading

Current US load standards

A number of US standards make reference to grate loading. There is no current standard that specifically deals with trench drains of different widths.

Where possible, to enable comparison between the loading specified within each standard, equivalent stresses (psi) are calculated from the specified test load and test block size of each standard.

To assist with applying these standards to ACO products, a guide is provided below equating stresses (psi) to the Load Class A - F categories from EN 1433 : 2002 Drainage channels for vehicular and pedestrian areas. It is also broken down by internal channel widths.

Load class certification for each product is available upon request.

EN 1433 Load Class of similar or equivalent rating:		
Internal channel width		
4<8"	8<12"	>12"

Common standards in North America:

ASME: A112.6.3 - 2001

Plumbing standard relating to internal floor drains.

Light Duty (Live Load < 2,000lb)	A - B	A - B	A - C
Medium Duty (2,000lb < Live Load < 4,999lb)	B - C	B - D	C - D
Heavy Duty (5,000lb < Live Load < 7,499lb)	C - D	D	D - E
Extra Heavy Duty (7,500lb < Live Load < 10,000lb)	D - E	E	E - F
Special Duty (Live Load > 10,000lb)	E - F	E - F	F

AASHTO Standard Specification for Highway Bridges

Standard relating to design for bridges. Loadings are dealt with by wheel 'footprints' and axle ratings. No specification is given for measurement of the performance of trench drains.	HS20		
	C - F	C - F	E - F
General specifications relate to vehicle loading up to HS20/HS25. Maximum truck weight 90,000lbs - 3 axles.	HS25		
	C - F	C - F	E - F

200,000lb proof load

The lack of a very heavy duty test standard created the need for a 'line of measurement'.			
Manufacturers of cast iron access covers used the structure of the RR-F-621E standard with 9" x 9" test block, but promoted the use of a 200,000lbs proof load - 2,469psi.	F	F	F
Although no independent standard refers to this measure, it has become widely accepted as a 'line of measurement' for very heavy duty loadings.			

FAA AC: 150/5370-10 - Item D-751

Airport standard that covers manholes, catch basins and inspection holes. No measurement or specification given for testing.	<i>Insufficient data</i>
--	--------------------------

FAA: 150/5320-5B & 6D

Standard relating to airport drainage and pavement designs. Loadings up to 100,000lbs, but no specific test procedure specified.	<i>Insufficient data</i>
--	--------------------------

AASHTO: M306 - 10 Drainage Structure Castings

Standard relating to castings in roadways	<i>See HS20 / HS25</i>
---	------------------------

* Although the chart indicates that the minimum psi for HS20 falls into the top of Load Class B range, ACO strongly recommends using Load Class C or higher due to the volume and dynamic nature (speed, turning & braking) of traffic in typical HS20 applications.

Load standard comparison chart

Pounds per square inch (PSI) comparison of load testing

4 in. - 8 in. internal width channels

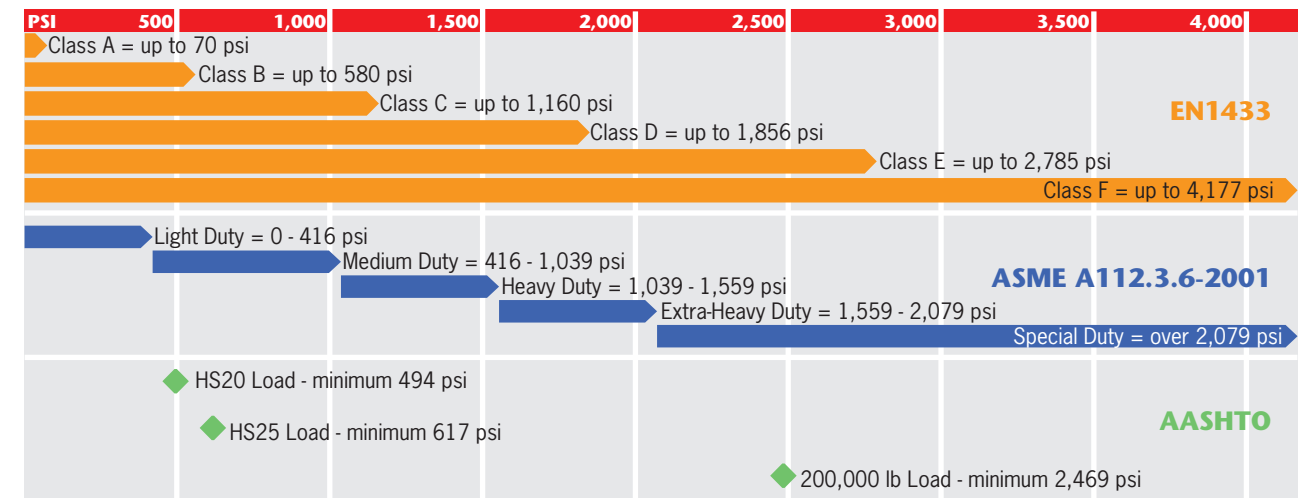

8 in. - 12 in. internal width channels

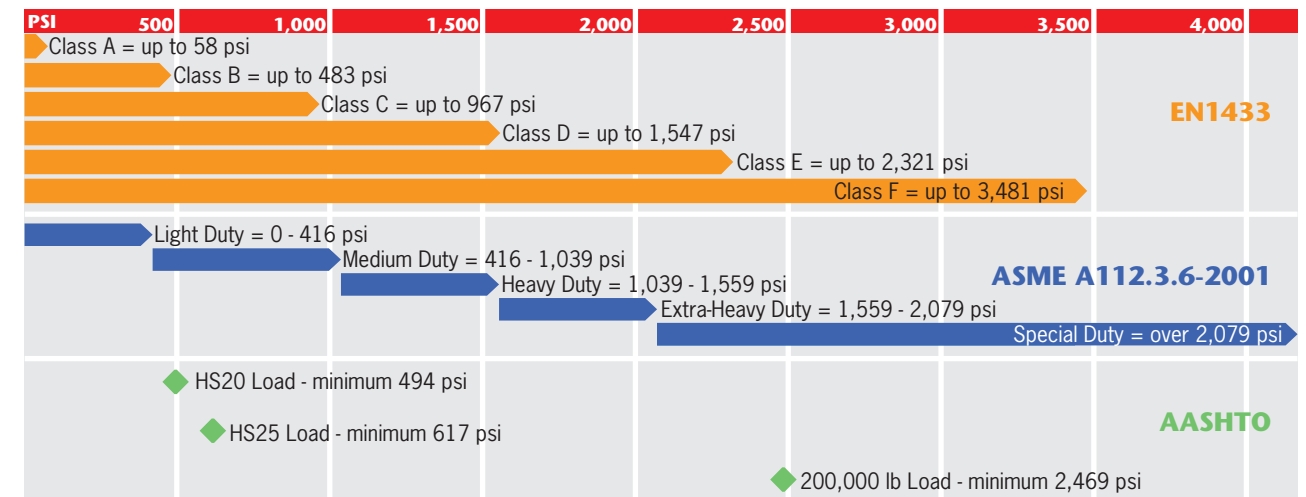

over 12 in. internal width channels

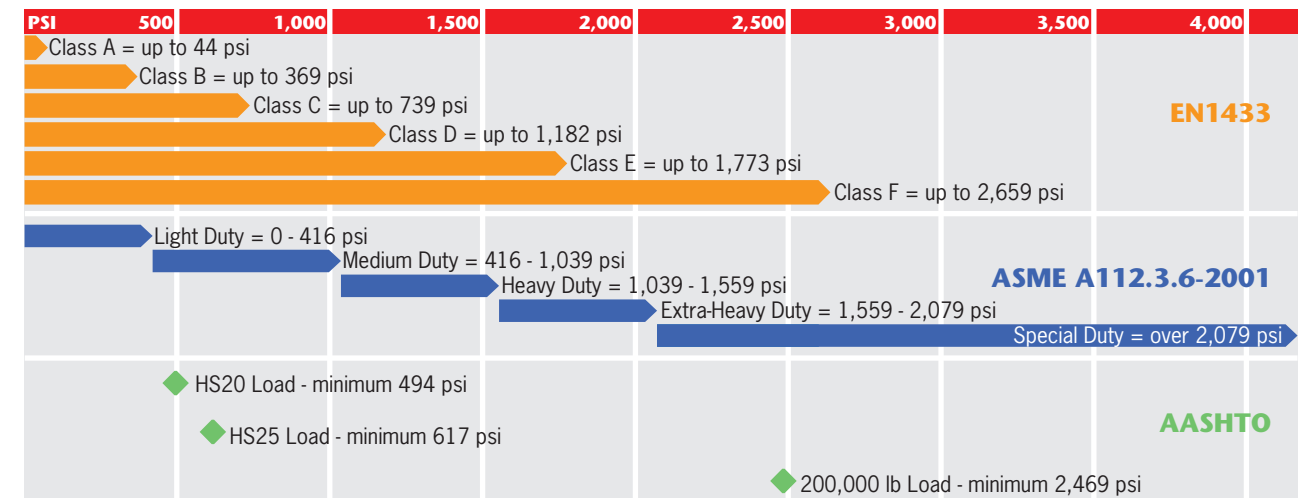

1.a Application - Loading

A **Load Class A - 3,372 lbs - 15kN (44-70 psi)**
Residential and light pedestrian traffic

B **Load Class B - 28,100 lbs - 125kN (369-580 psi)**
Sidewalks and small private parking lots

C **Load Class C - 56,200 lbs - 250kN (739-1,160 psi)**
Parking lots and general commercial areas

D **Load Class D - 89,920 lbs - 400kN (1,182-1,856 psi)**
Trafficked sections of roads and highways

E **Load Class E - 134,800 lbs - 600kN (1,773-2,785 psi)**
Aircraft hangars, industrial areas, gas stations and light commercial forklifts

F **Load Class F - 202,320 lbs - 900kN (2,659-4,177 psi)**
Aircraft runways, military establishments, docks, heavy industrial, heavy fork trucks and very heavy wheel loads

Load testing

EN 1433

The only standard written specifically for trench drains, and internationally recognized, is EN 1433: 2002 Drainage channels for vehicular and pedestrian areas.

EN 1433 accounts for different widths of grates. For trench drains less than 200mm wide, test block for load testing is 10" long by 3" wide. For trench drains 200mm to 300mm wide, test block is 10" long by 6" wide; for trench drains over 300mm, the test block is 10" diameter. This ensures that the full force of the test load is directed onto the grate.

EN 1433 also prescribes testing methods for system testing (the complete trench drain and grate). It accounts for both proof loading and catastrophic failure.

EN 1433 also outlines system testing for monolithic trench drains (grate and body manufactured as a single unit). See ACO Infrastructure for monolithic trench drains.



EN 1433 load test - with width specific test block

Diagrams show test load applied to typical grates through an EN 1433 prescribed width specific test block. Test blocks are sized to ensure the entire test load is applied to grate NOT grate supports - this ensures relevant results for all trench drain widths.

Grate for 4 in. internal width trench drain

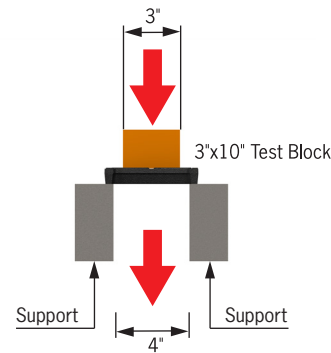
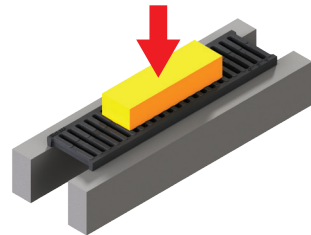

Diagram shows test block positioned centrally on grate - full test load is being applied to grate giving a meaningful result.

Grate for 8 in. - 12 in. internal width trench drain

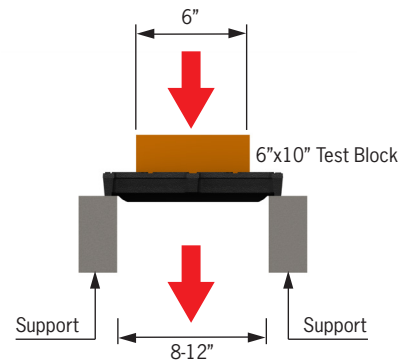
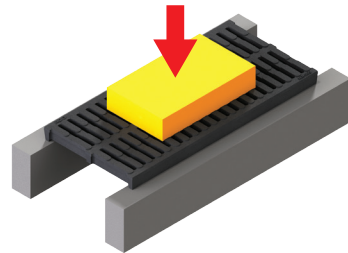

Diagram shows test block positioned centrally on grate - full test load is being applied to grate giving a meaningful result.

Grate for over 12 in. internal width trench drain

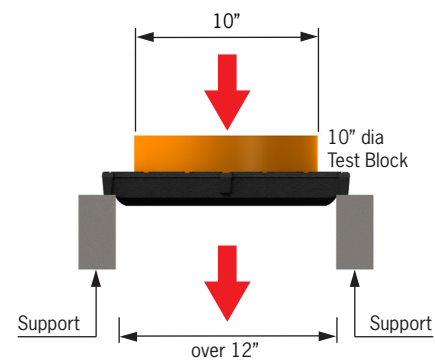
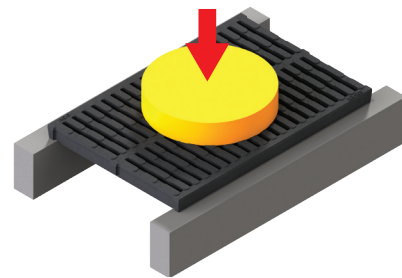

Diagram shows test block positioned centrally on grate - full test load is being applied to grate giving a meaningful result.

ASME: A112.6.3 load test - 3.5 in. dia. test block AASHTO load test - 9 in. x 9 in. test block

This load standard is designed for small internal floor drains and prescribes a smaller (3.5" dia.) test block therefore exerting entire test load into the grate, providing relevant results for all trench drain widths.

Grate for 4 in. internal width trench drain

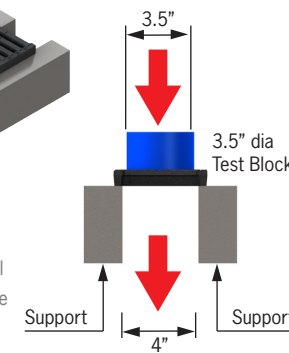
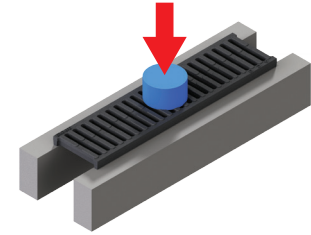

Diagram shows test block positioned centrally on grate - full test load is being applied to grate giving a meaningful result.

Grate for 8 in. - 12 in. internal width trench drain

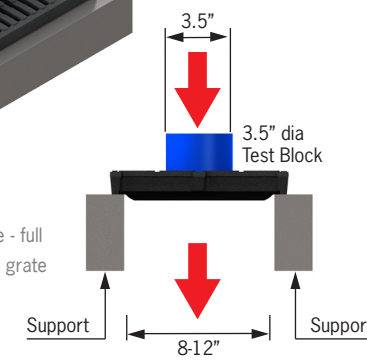
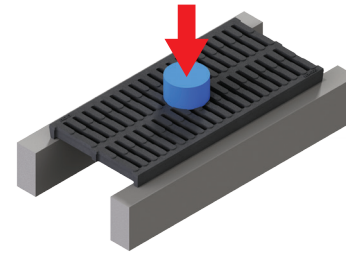

Diagram shows test block positioned centrally on grate - full test load is being applied to grate giving a meaningful result.

Grate for over 12 in. internal width trench drain

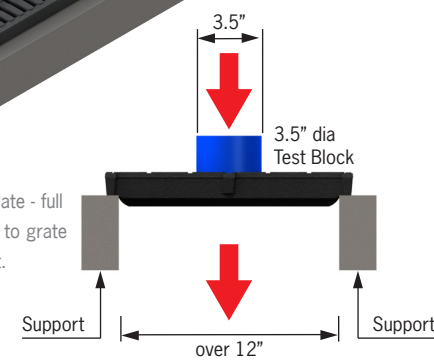
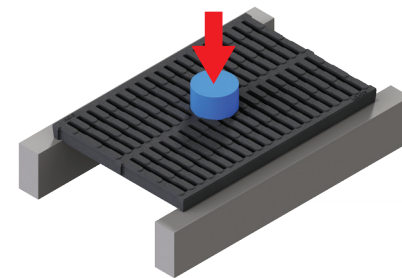

Diagram shows test block positioned centrally on grate - full test load is being applied to grate giving a meaningful result.

Grate for 4 in. internal width trench drain

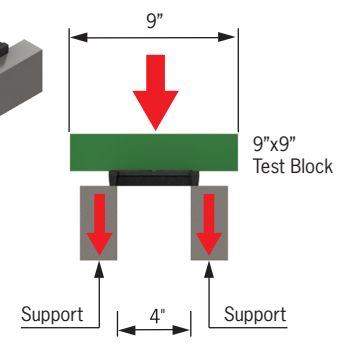
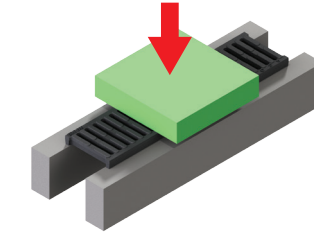

Diagram shows test block positioned centrally on grate - full test load is NOT being applied to grate giving an unreliable result.

Grate for 8 in. - 12 in. internal width trench drain

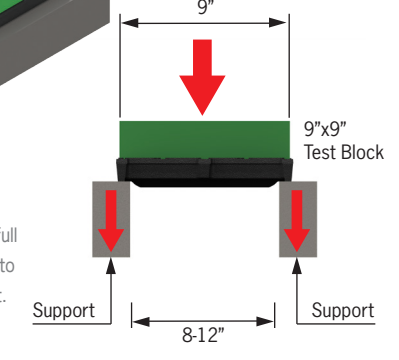
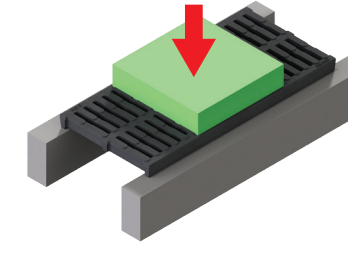

Diagram shows test block positioned centrally on grate - full test load is NOT being applied to grate giving an unreliable result.

Grate for over 12 in. internal width trench drain

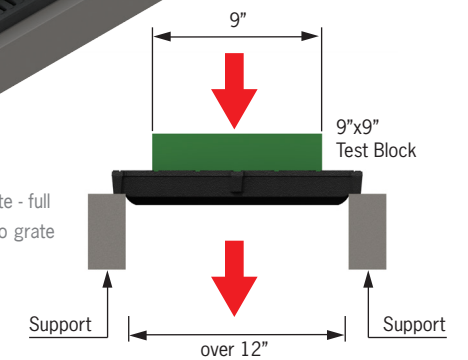
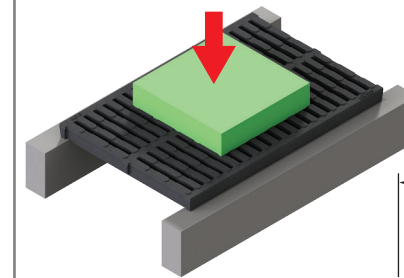

Diagram shows test block positioned centrally on grate - full test load is being applied to grate giving a meaningful result.



Installation details - Loadings

Load categories

To assist product selection, ACO independently tests each channel and grate to an internationally recognized load standard - EN 1433. Results are categorized into 6 classes from light duty - 'A' to heavy duty - 'F'.

ACO offers advice on the most appropriate load class. An overview, and comparison of EN 1433 and other commonly referenced US load standards is provided on pages 128-129.

To advise on most appropriate Load Class, the following information is required:

- Type of traffic
- Location of trench - bottom of ramp, alongside building, etc.
- Wheel type, if appropriate
- Vehicle/cart weight and weight of typical load
- Typical vehicle speed
- Traffic flow pattern - along or across trench? Turning or braking on trench?
- Unusual traffic - snow plows, dumpsters, etc.

Concrete surround

Loading will also impact the size of concrete encasement required. It is recommended that the cement concrete encasement be durable and conform to minimum strength requirements shown in ACO's recommended installation detail.

Poor site conditions and low load bearing pavements will require an increase in these dimensions to meet both vertical and lateral loads.

Some applications will also require concrete reinforcement.

To select correct section detail, the following information is required:

Always seek engineering advice for specific applications.

- Load class
- Product type & width (e.g. KlassikDrain K200)
- Pavement finish

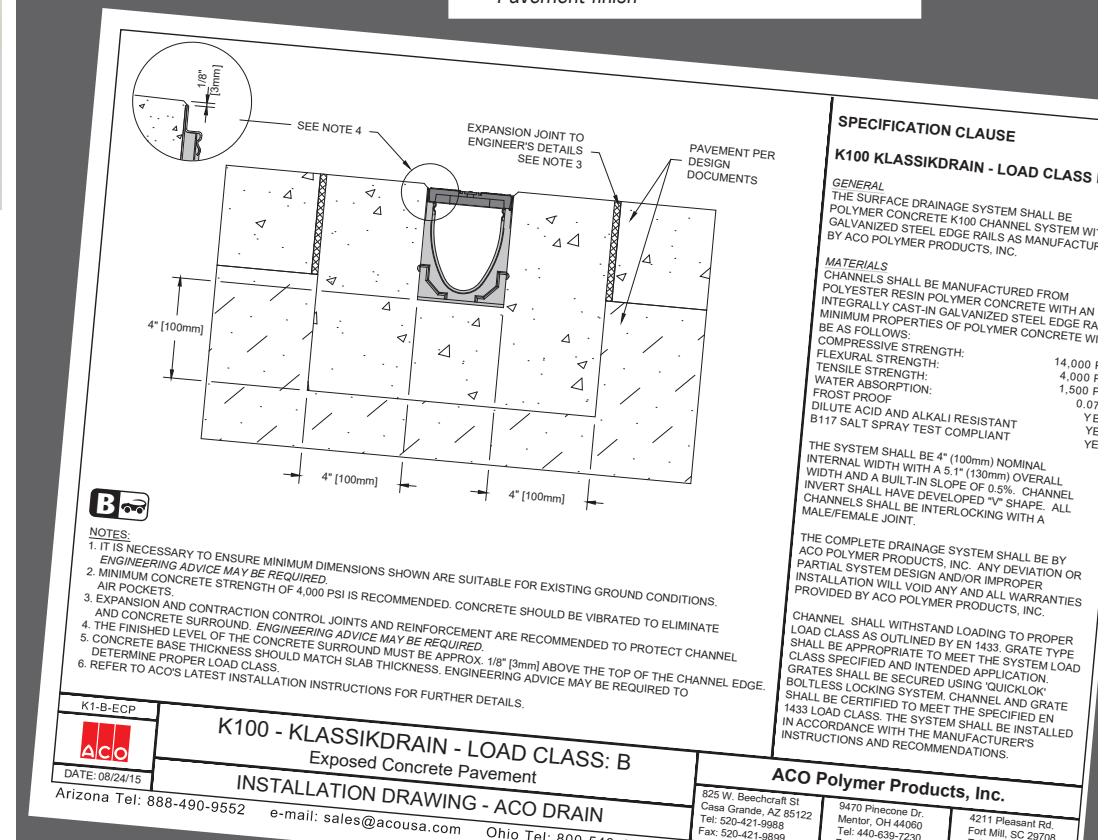

Factors affecting loading

Contact area

Contact area between load and trench drain grate affects pressure (psi) exerted by load. Typically relates to tire type, but can include anything that may rest permanently or periodically on trench drain.

Loading - often referred to as traffic - is any weight that will rest on, or travel over, the trench drain.

Traffic includes pedestrians, livestock, machinery and vehicles - basically anything that will be going over the trench drain.

Traffic is the most important factor in pavement design. A trench drain is an integral part of the pavement. Therefore, traffic is also the number one consideration when determining the type of trench drain (both channel and grate) and the concrete encasement required for each application.

During the construction phase it will be necessary to protect the trench from site traffic. See page 154 for details.

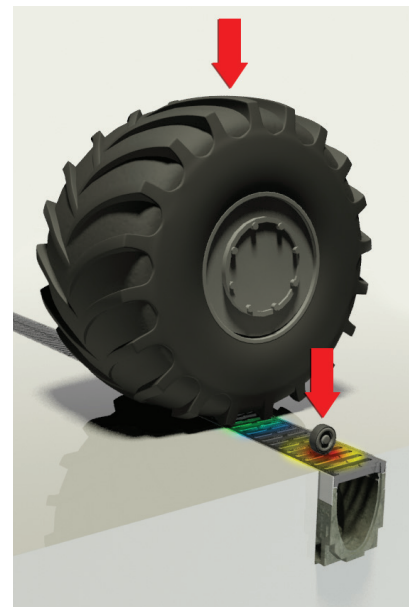

Small and/or solid tires concentrate load onto a small contact area - exerts a higher pressure (psi). This application requires grate and/or trench system with higher load rating.

Larger and/or pneumatic tires spread load over larger contact area - exerts lower pressure (psi).

Wheel loads

Combined with contact area to calculate loading.

- Weight of vehicle/cart and its typical load, eg. forklift & weight of typical loaded pallet
- Number of wheels and axles that load is distributed over, affects individual wheel load
- Unusual traffic, e.g. dollies/dumpsters going over trench

Load frequency

It is also important to consider how often load is applied. Frequent or continuous loads will require heavier duty trench drain and/or larger concrete encasement detail than occasional loads of same weight.

Dynamic vs static loads

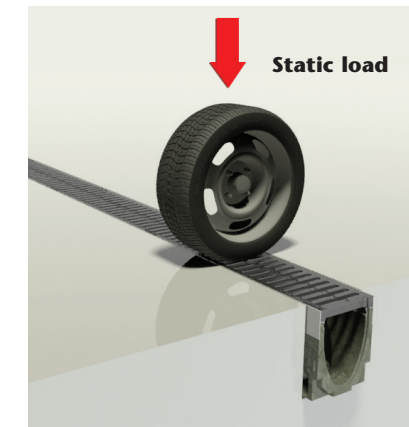

Static loads are a load/weight applied vertically onto the trench - no other movement. Not typically found in real life scenarios, but are used for load testing a grate or trench drain. They provide an objective measuring scale to rate loadings of grate/trench drain.

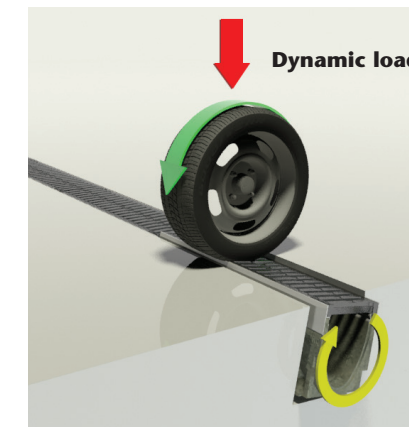

Dynamic/moving loads - forces rise rapidly as traffic speed increases. Factors that intensify dynamic loading include:

- Vehicles traveling across or along trench
- Traffic braking, accelerating or turning on trench
- Speed of traffic
- Trench located at top or bottom of a ramp

Forces created by dynamic loads tend to twist trench drain and grates out of position. The more movement (turning and/or braking) and/or faster traffic, the greater the dynamic load. Trench body, grate type, installation detail, and locking mechanisms, are all important factors to consider when addressing dynamic loads.



1.b Application - Site requirements

Trench materials

Modular trench drain systems are generally manufactured from polymer concrete, fiberglass or HDPE (High Density Polyethylene).

ACO Drain commercial trench systems are manufactured from either polymer concrete or fiberglass. Other materials do not meet the compressive strength and thermal expansion properties required in commercial and industrial projects. ACO uses plastics primarily as a grate and trench material for residential applications (ACO Self).

Polymer concrete

Polymer concrete is a composite material produced by mixing mineral aggregates with a resin binding agent. The finished material has excellent mechanical and thermal properties and offers good corrosion resistance to many chemicals. A maximum working temperature of 180°F (82°C) is recommended.

Due to their structural rigidity, polymer concrete trench drains can be used in a variety of pavement types such as concrete, asphalt and brick pavers.

Fiberglass

Fiberglass uses similar resin binding agents to those used for polymer concrete, but glass mat and fibers are used instead of mineral aggregates to provide a robust flexible material.

Fiberglass trench drains are designed to be fully encased in concrete.

Cement concrete

Cement concrete is Portland cement mixed with mineral aggregates. Generally used for large cast-in-place slab applications, where mass is required for structural rigidity.

Expanded polystyrene formers have disposal concerns, and are often released using gasoline. Local EPA regulations should be complied with.

Plastics

The most common plastic used in a trench drain is polyethylene - usually HDPE (High density PE) or MDPE (Medium density PE). Both HDPE & MDPE are readily available, economical materials that are easy to mold.

Plastic trench drains are designed to be fully encased in concrete, however, HDPE/MDPE have thermal properties that require the addition of concrete keying features to securely anchor the product within the concrete slab. Without adequate concrete keying features the trench may lose bond (pull away) from the concrete encasement and buckle, ultimately leading to product failure. This is of particular concern in applications where short term wide temperature ranges are expected, and/or long trench runs are involved.

Metals

Trench drains can also be fabricated from mild or stainless steel. ACO recommends stainless steel trench drains for hygienic applications. See ACO Building Drainage products for details.

A material comparison chart is provided opposite and chemical resistance chart on page 139.

Grate materials

Grates are manufactured from a variety of materials. The most common are ductile iron, mild steel, stainless steel and plastic.

Grates need higher bending strength properties than the trench body to withstand flexural loads. Unlike the trench drain body, grates can be removed and replaced after installation.

In commercial applications, all grates should be locked in place to ensure user safety and channel longevity.

Edge protection

The exposed edge of the trench helps pavement to maintain a visual straight line and helps hold the grate in position. The exposed edge is subjected to the same loads as the grate. In addition to effect of climate and traffic, the edge is exposed to impact from items being dropped or pulled across it (e.g. snow plows). Once the edge fails, the grate will move and cause catastrophic failure.

Metal edges are most commonly used as a wearing rail to withstand rigorous and repetitive traffic. Edge protection rails should be integrally cast-in or mechanically connected to the trench body. Edge rails that sit over existing standard edges are often ill-fitting and susceptible to failure.

Edge rails also provide some protection during installation. Appropriate edge protection is particularly important in asphalt situations where rolling machines can damage exposed edges, leading to premature trench drain failure.



Non-metallic option



 Polymer concrete is an ideal material for non-metallic requirements. It offers excellent insulation properties - electrical resistivity rating of $1 \times 10^8 \Omega/\text{sq}$.

H100 is a 100% polymer concrete channel that can be used with non-metallic grates (Types 494Q/495Q - See ACO Sport range) to provide a 100% non-metallic trench drain system.

Call ACO's Technical Services Department for additional suggestions if this is not a suitable solution.

SERVICE B



Trench materials - physical properties

Different materials offer different surface and physical performance properties which may affect their suitability of use in various applications. These charts provide a side by side comparison.

Surface properties	Fiberglass	Cement Concrete	Polymer Concrete	Polyethylene HDPE
Surface burning Trench systems are often used around gas stations, chemical processing and interior applications and may be subject to fire; they should be non-flammable and not give off fumes or smoke.	After flame time: 216 seconds - fail UL-94	7 rating E119	Flame spread: 0 Smoke density: 5 E84	After flame time: 390 seconds - fail UL-94
Weathering The majority of trench drains are used in exterior applications. Ability to withstand adverse weather will ensure long service life (erosion, UV degradation etc).	1000hr exposure no change G-153*	^a Good depending upon proper curing	2000hr exposure no change G-153*	^b 1000hr exposure no change FAIL G-153*
Roughness Coefficient (Manning's) Any degree of friction will affect liquid flow to an extent, therefore the lowest value is desirable.	n=0.008	n=0.013	n=0.011	n=0.010
Chemical resistance Trench may be used for chemicals - for chemical resistance data see page 139.	Good	Poor	Good	Good
Mechanical properties				
Compressive strength The trench body is subject to compressive loads in use and needs to withstand the specified load.	24,400psi D-695	4,500psi C-39	14,000psi C-579	8,450psi D-695
Flexural strength Affects site handling and when trench body is in areas where encasement and soils are suspect.	9,943psi D-790	587psi C-78	4,000psi C-580	2,224psi D-790
Bending strength Not generally required in trench bodies, but relevant to grates. Used as material measurement.	7,378psi D-638	^c 419psi	2,000psi C-307	1,993psi D-638
Thermal properties				
Water absorption The trench is designed to carry and collect liquids without contaminating surrounding soil/encasement.	+0.33% D-570	+5.00% C-97	+0.07% C-97	+0.31% D-570
Freeze-thaw Inability to withstand freeze-thaw cycles causes surface spoiling and leads ultimately to trench failure.	223 cycles modulus of elasticity 89.5% C666	300 cycles maintain 80% structural integrity	300 cycles modulus of elasticity 95.1% C666	223 cycles FAILED modulus of elasticity test C666
Coefficient of expansion/contraction Excessive movement between trench and trench surround creates debonding, causing unwanted stresses and possible failure.	^d $6-17 \times 10^{-6}$ per °F D696-03	6.5×10^{-6} per °F D696-03	11.0×10^{-6} per °F D696-03	54.0×10^{-6} per °F D696-03
Water vapor transmission WVT is measurement of water vapor flow through a material. Passage of water vapor may be critical.	WVT - 0.109g/m ² 1,592hrs E96	See water absorption test	WVT - 0.036g/m ² 1,592hrs E96	WVT - 0.139g/m ² 1,592hrs E96

Key

- a. Carbonation can affect steel rebar leading to poor weathering (PCA Design & Control of Concrete Mixtures - 14th ed).
 - b. Bending exceeded 5% strain - unable to complete test.
 - c. Equals $6.25 \times \sqrt{\text{compressive strength (psi)}}$ - (PCA Design & Control of Concrete Mixtures - 14th ed).
 - d. Variance due to many manufacturing processes for fiberglass - FG200 falls into the higher part of the range.
- * Test was done to prior standard but procedure requirements were identical.





1.a Application - Site requirements

Sustainable drainage

In an environmentally perfect world permeable landscapes would be everywhere, allowing nature to work as intended. However, in reality, this is not possible and hard landscapes are common.

Sustainable drainage is the collection of rainwater, its treatment and, ultimately, its reuse.

The process involves collecting water runoff (that may or may not contain pollutants) and allowing it to be dealt with in a controlled manner - i.e. treated, stored for future use, or discharged to receiving waterways, ideally at low cost, and with minimal impact to the environment.

Surface drainage can be used to assist the 'collect' part of this process. Trench drains are ideal as they provide maximum collection and can form a barrier to prevent runoff flowing onto sensitive areas or soft landscaping. This is particularly important if the toxicity risk of pollutants is high, such as highway and gas station applications.



EPA requirements

Stormwater runoff is generated from rain and snowmelt events flowing over land or impervious surfaces, and not percolating into the ground. As the runoff flows over the land or impervious surfaces (paved streets, parking lots, and building rooftops), it accumulates debris, chemicals, sediment or other pollutants that could adversely affect water quality if the runoff is discharged untreated.

The primary method to control stormwater discharges is the use of Best Management Practices (BMPs). In addition, most stormwater discharges are considered point sources and require coverage under an NPDES permit.

LEED

Leadership in Energy and Environmental Design provides a green building rating system. Principles have been applied to commercial and institutional projects, schools, multi-unit residential buildings, manufacturing plants, laboratories and other building types.

Areas where the use of trench drainage may assist in assignment of credits include:

SUSTAINABLE SITES

- Protect or Restore Habitat

Compared to catch basins, trench drains require minimal excavation; reducing site restoration requirements.

- Rainwater Management

Trench drains offer maximum capture of run-off, allowing for on-site nonpotable uses such as irrigation. Run-off can also be quality assessed and treated as required.

WATER EFFICIENCY

- Water Use Reduction

Reclaimed water/Alternative water source - use of trench drains to capture rainwater for future irrigation/toilet flushing use to achieve increased water use reduction.

MATERIALS & RESOURCES

- Construction & Demolition Waste Management

To reduce construction and demolition waste disposed of in landfills and incineration facilities by recovering, reusing, and recycling materials.

Compared to catch basins, trench drains require minimal excavation; reducing site waste/debris.

Go to www.usgbc.org for full details.



Chemical resistance

ACO Drain channel bodies are highly resistant to chemical attack and, with the appropriate grate, can be used in most environments where everyday acids and dilute alkalis are encountered.

Important considerations for chemical environments

When reviewing potential applications of trench drains in chemical environments, the following issues should be considered:

1. Type(s) & mixture of chemical(s).
2. Concentration percentages.
3. Contact time with trench system.
4. Temperatures of chemicals flowing into the trench drain. 180°F (82°C) max.
5. Flushing system employed to clear chemicals from the system.
6. Cleaning agents should be checked for compatibility with trench materials.
7. ACO test coupons can be used for final determination of chemical resistance.
8. Grate, locking mechanism, edge rail, outlet and trash bucket materials should be checked for chemical resistance.
9. Check sealant for compatibility, if applicable.

SERVICE C



Chemical resistance chart

These recommendations are for guidance only. They are based upon information compiled from resin plastic manufacturers. Customers are advised to test a coupon of polymer concrete to ensure suitability. Test coupons are available free of charge from ACO.

If ACO Drain standard products are unable to provide adequate chemical resistance, contact ACO (800) 543-4764 for a suitable product solution.

Chemical Medium	Max. conc.	Short time exposure 72 hours	Long time exposure 42 days
Acetic Acid	30%	✓	✗
Acetone	10%	✓	✗
Ammonia	10%	✓	✗
Aniline	100%	✓	✗
Aniline in Ethyl Alcohol	10%	✓	✓
Benzene	100%	✓	✗
Boric Acid	100%	✓	✓
Butyric Acid	25%	✓	✓
Butyl Alcohol	100%	✓	✓
Calcium Chloride	100%	✓	✓
Calcium Hydroxide	100%	✓	✗
Caster Oil	100%	✓	✓
Chloric Acid	5%	✓	✗
Chromic Acid	5%	✓	✓
Citric Acid	100%	✓	✓
Diesel Fuel	100%	✓	✓
Ethanol	100%	✓	✗
Ethlendiamine	100%	✓	✓
Ethyl Acetate	100%	✓	✗
Ferrous Sulfate	30%	✓	✓
Fluoralic Acid	10%	✓	✓
Formaldehyde	35%	✓	✓
Formic Acid	10%	✓	✗
Fuel Oil	100%	✓	✓
Gasoline	100%	✓	✓
n-Heptane	100%	✓	✓
n-Hexane	100%	✓	✓
Hydraulic Oil	100%	✓	✓
Hydrochloric Acid	10%	✓	✓
Hydrofluoric Acid	5%	✓	✗
JP4	100%	✓	✓
JP8	100%	✓	✓
Lactic Acid	10%	✓	✓
Methanol	5%	✗	✗
Methyl Amine	100%	✓	✗
Methyl Ethyl Ketone	100%	✓	✗
Mineral Oil SAE5W50	100%	✓	✓
Monochlor Benzene	0.05%	✗	✗
Monochloroacetic Acid	10%	✓	✓
Nitric Acid	10%	✓	✗
n-Nonane	100%	✓	✓
Iso-Octane	100%	✓	✗
Oxalic Acid	100%	✓	✓
Phenol	100%	✓	✗
Phosphoric Acid	10%	✓	✓
Potassium Hydroxide	10%	✗	✗
Sodium Acetate	100%	✓	✗
Sodium Carbonate	20%	✓	✓
Sodium Chloride	100%	✓	✓
Sodium Hydroxide	15%	✓	✗
Sodium Hypochloric	5%	✓	✓
Sulfuric Acid	40%	✓	✓
Tetrafluoroborsaur	20%	✓	✗
Toluene	100%	✓	✗
Trichloroethylene	100%	✗	✗
Triethylamine	100%	✓	✓
Xylene	100%	✓	✗

Note: Maximum operating temperature of 180°F (82°C)

ASTM - B117 Salt Spray Test

ACO polymer concrete has passed independent tests and is unaffected by road de-icing salts. This test is an accelerated corrosion test that produces a corrosive attack to predict a material's suitability in use. The ACO test sample showed no sign of degradation after 1,000 hours of salt spray exposure.

Hydrocarbons

Stormwater run-off frequently carries the risk of containing hydrocarbons. Trench drains in high risk areas; i.e. gas stations and airports almost always drain into oil-water separators. Refer to ACO Environment for details.

ACO now offers solutions for hydrocarbons to be removed at the outlet - these solutions are ideal for applications where the risk is lower, and/or where space does not allow for the use of an independent oil-water separator. Call ACO for details.



1.c Application - User requirements

Once trench drain choice has been narrowed by determining loading and durability requirements, options relative to project specific end user needs, or legislative obligations, need to be considered.

ACO can provide product guidance based on current industry standards and requirements. When third party testing has been carried out copies of test certificates are also available.

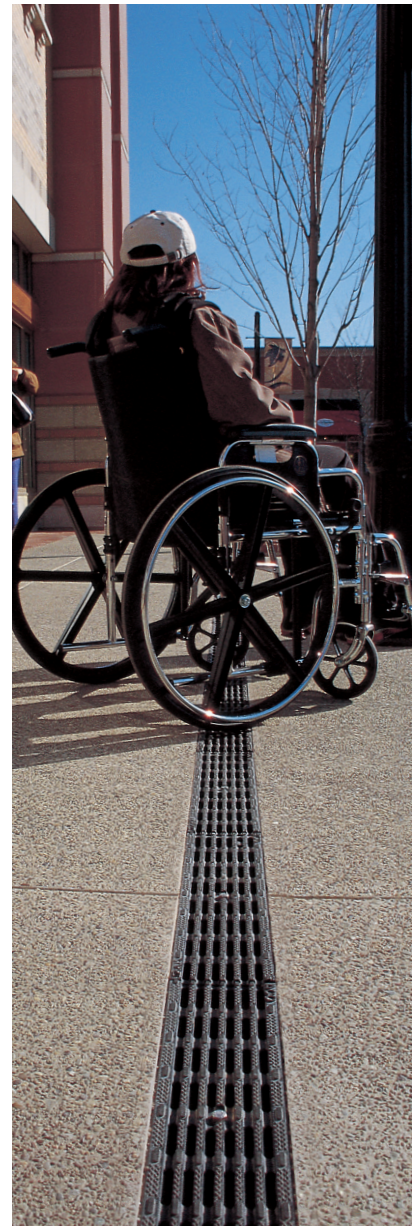

1. Legislative compliance

Trench drains are commonly used in public areas where accessibility is a concern and ADA legislation must be met. A number of grates are available that provide ADA compliance without compromising aesthetics or performance.

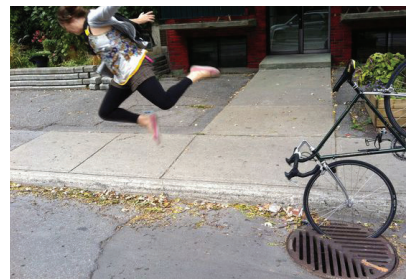

2. User safety

ACO has categorized grate safety into 3 main types:

- Heel resistant - complies with ASME: A112.6.3
- Heel safe - Narrow slots for stiletto heel safety
- Bicycle safe - complies with AS 3996



3. Grate security

ACO recommends that grates should be secured to prevent movement by traffic, which can cause damage to the trench and/or grate.



4. Aesthetics

The top of the trench, usually the grate is the most visible part of the trench drain and aesthetically the most important.

Grates can be selected to blend into the pavement, or used as a feature or border.



5. Slip resistance

Slip resistance is critical for user safety. Ideally the slip resistance of the grate should be similar to the surrounding pavement to avoid both slip and/or trip hazards.

SERVICE D



Selection guidance and test data

ADA REQUIREMENTS are set out in The Americans with Disabilities Act of 1990; Section 4.5.4.



Where grates are used within walking surfaces, the open slots should be no greater than 0.5 inches (12.7mm) wide in one direction. Where the length of the slot is greater than 0.5 inches, the opening should run perpendicular to the main direction of traffic

The diagram shows the slots perpendicular to the flow of traffic; this helps prevent wheelchair wheels and walking aids becoming trapped or slipping on the grate surface.

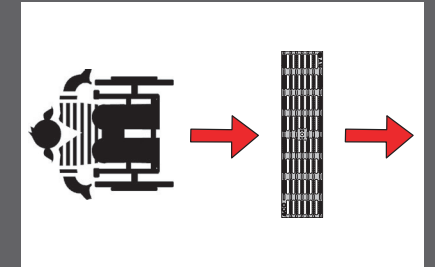

HEEL RESISTANT - ASME: A112.6.3 : Section 7.12 Heel Resistant Strainers & Grates



A grate designed to resist entry of heeled shoes, in which the maximum grate hole size in least dimension shall be **0.31" (8mm)**.

HEEL SAFE



For applications where high stiletto heels are commonplace, ACO recommends grates with openings of 0.25" (6.5mm) or less to prevent heels from becoming trapped, causing injury or falls.

BICYCLE SAFE - AS 3996 - 2006 Clause 3.3.6



No US Standard exists detailing slot sizes to avoid bicycle tires from becoming trapped. ACO rates grates based on Australian Standard AS 3996 - 2006 Clause 3.3.6 which specifies maximum slot length dependent on slot width for grates that are deemed Bicycle Tire Penetration Resistant.



There are a number of locking options available, including:

BOLTLESS LOCKING - mechanisms that hold grates captive without use of bolts. They are quick to install and remove, making installation and maintenance easier.

BOLT LOCKING - uses bolts to hold grates in place. Bolts fasten into either the frame or locking bar that straddles the trench.

OTHER LOCKINGS - on rare occasions, something other than standard lockings are required, such as tamper resistant bolts. Contact ACO for more information.



Aesthetic options are typically based on:

GRATE MATERIALS - stainless steel, ductile iron and plastic can all offer excellent aesthetics. Monolithic trench drains are manufactured using the same material for the grate and trench drain body.

GRATE SLOT PATTERNS - perforated, slotted, mesh and decorative patterns are available.

To help determine the right aesthetics for a project, ACO offers an online grate *Visualizer* that allows pavement and grate choice combinations to be viewed.

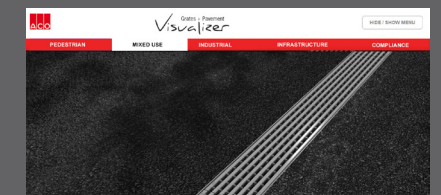

ACO has tested grate patterns using the widely accepted pendulum test.

PENDULUM TEST - A pendulum is swung over a wet surface and measures surface frictional properties. Test results are given a BPN value - typically values in excess of 24 would be used (24 and under is regarded as high slip and skid potential).

ACO recommends selecting a grate with the similar BPN values as the surrounding pavement finish. Pavement slope, presence of surface contaminants, etc. can also negatively affect slip and skid resistance.

Other tests exist, such as the Variable-angle ramp test and horizontal pull test and can be carried out as necessary if required for specific projects.





2. Hydraulics

Catchment hydraulics - calculating run-off

To calculate correct size of trench drain, catchment run-off must be calculated.

- Catchment area = pavement length x width (ft) **A** x **B**
- Rainfall intensity in inches per hour **C**

www.ACODrain.us

link to US government rainfall frequency atlas

Once catchment run-off **Q** is calculated, other inflows, e.g. down spouts, can be added. Other factors that affect trench drain hydraulics:

- Ground fall percentage **D**
- Pavement material - some materials absorb liquids, e.g. brick pavers **E**
- Position and size of outlet pipe **F**
- Surface roughness of trench material. Manning's coefficient of roughness figures. See page 137 **G**
- Angle of approach to trench - this can affect grate hydraulics (steep slopes may cause bypass) **H**

$$Q \text{ (GPM)} = \frac{\text{Area (AxB)} \times \text{Rainfall intensity (C)}}{60(\text{minutes}) \times 1.6(\text{Conversion to gallons})}$$

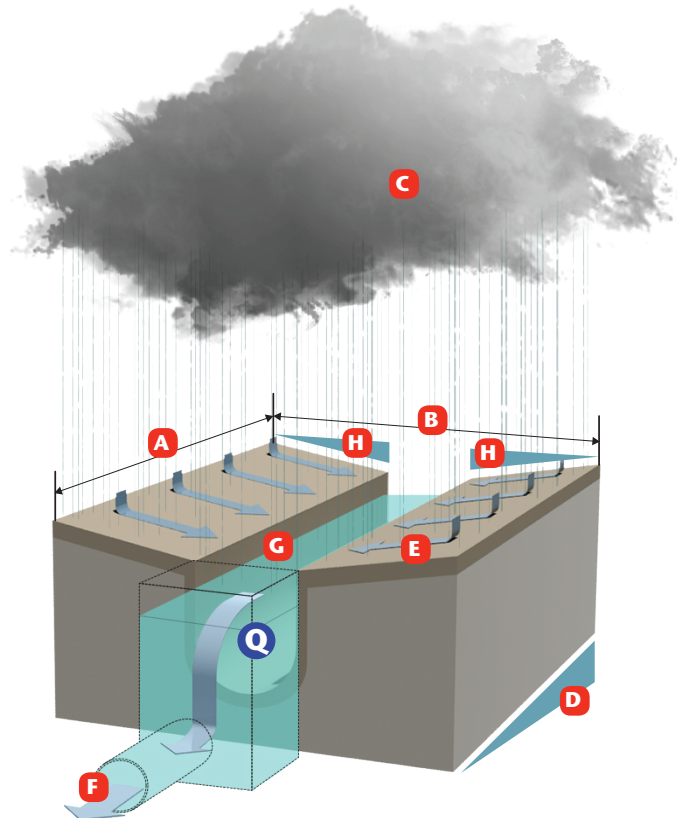

Non-uniform flow (Spatially Varied Flow)

$$\frac{dy}{dx} = \frac{S_0 - S - 2\alpha Qq / g A^2}{1 - \alpha Q / g A^2 D}$$

Non-uniform flow accounts for liquid being carried in a trench plus the constant addition of liquid collected through the grates along the trench run - lateral intake. Run lengths, therefore, also influence a trench drains capacity.

A characteristic of non-uniform flow is liquid velocity and height change at successive cross sections along the trench.

To correctly model this situation, differential calculus is required; usually computer modeling is needed.

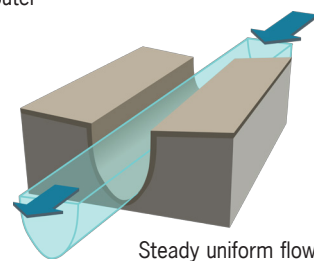
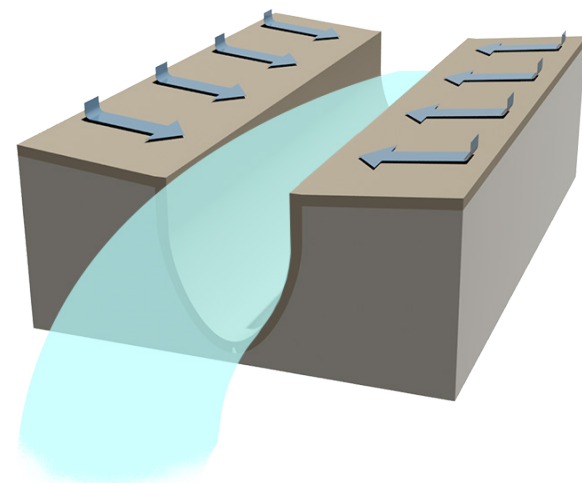

Steady uniform flow

SERVICE E



Hydro software - modeling trench hydraulics

To generate results from the Hydro program, the following information is required:

- Length of trench run (feet or meters)
- Length and width of catchment area (feet or meters). See page 142.
- Surrounding pavement/surface type, e.g., concrete, asphalt, etc.
- Rainfall intensity (in/hr or mm/hr)
- Ground fall along trench (%)
- Perpendicular approach slopes to trench (%)
- Preferred position of outlets along trench and any outlet size restrictions
- Any slab depth restrictions

Results are provided either electronically and/or in printout format, in metric or imperial units.

Electronic request form can be found at www.ACODrain.us.

Hydro printout shows:

- 1 Position and size of minimum freeboard (gap between underside of grate and top of liquid in trench)
- 2 Hydraulic profile of liquid
- 3 Flow velocity and flow rate at all points along the trench
- 4 Maximum discharge capacity of trench run. (42.9 GPM - 2.7 l/s from example below)
- 5 Hydraulic utilization of trench (%) is given. If over 100%, flooding occurs. (27.27% from example below)

Hydro is a purpose written, hydraulic design program modeled on differential calculus for non-uniform flow in open channels. See page 142. The program has been calibrated by empirical data following a series of experiments modeling lateral intake into trenches. Analysis of the effect of slope, run length, and trench cross sectional profiles are incorporated into the program.

Complex scenarios such as the effects of water inflow from down spouts or inlets along the length of the trench can also be modeled by the Hydro program. ACO can use Hydro to recommend optimum outlet positions along trench runs.

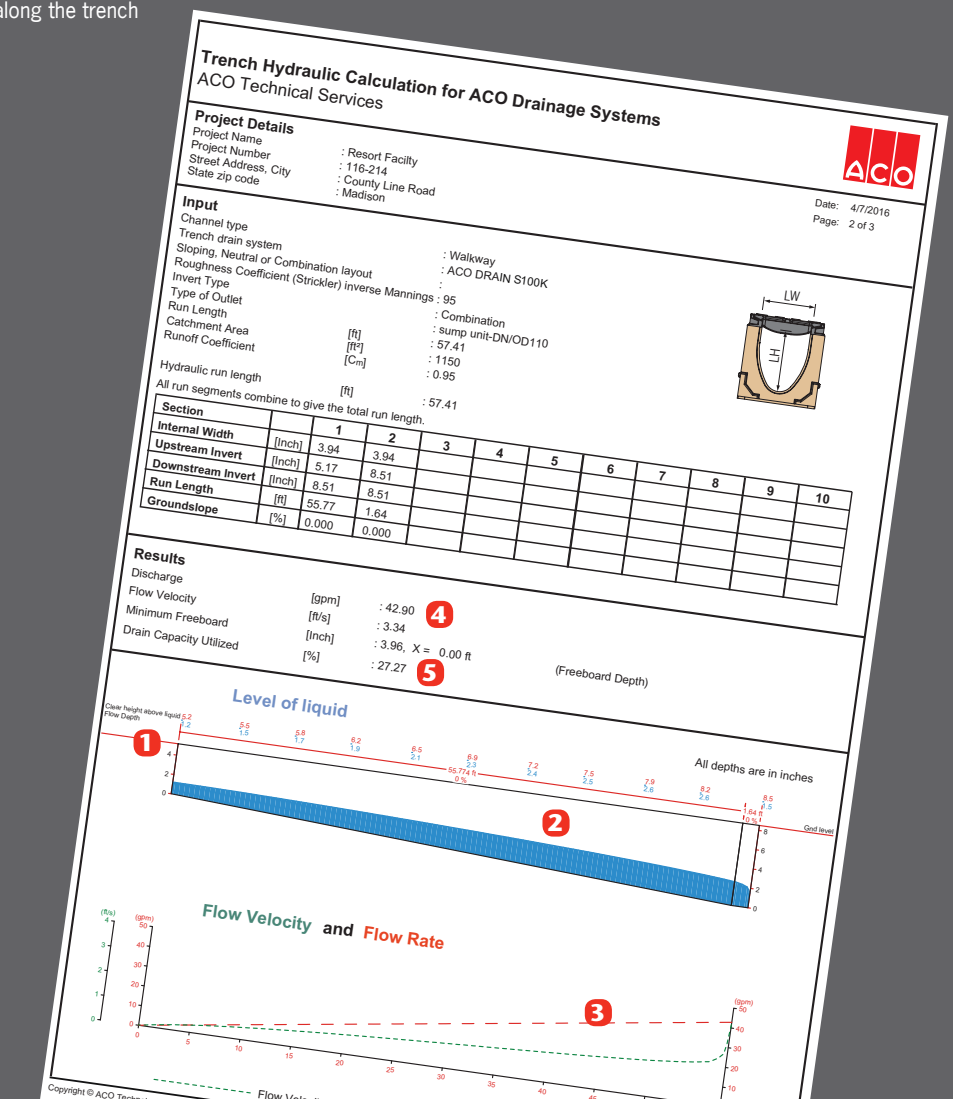



2. Hydraulics

Effect of slope on trench hydraulic performance

Slope increases the hydraulic performance of the trench system because flow velocity is increased. The drawings below highlight the water profile in the trench - all parameters are the same on both examples except lower image has a 1% slope added.

This increase in capacity may result in larger areas being drained, outlets spaced further apart, or a narrower or shallower trench system being specified which will result in product and/or installation savings.

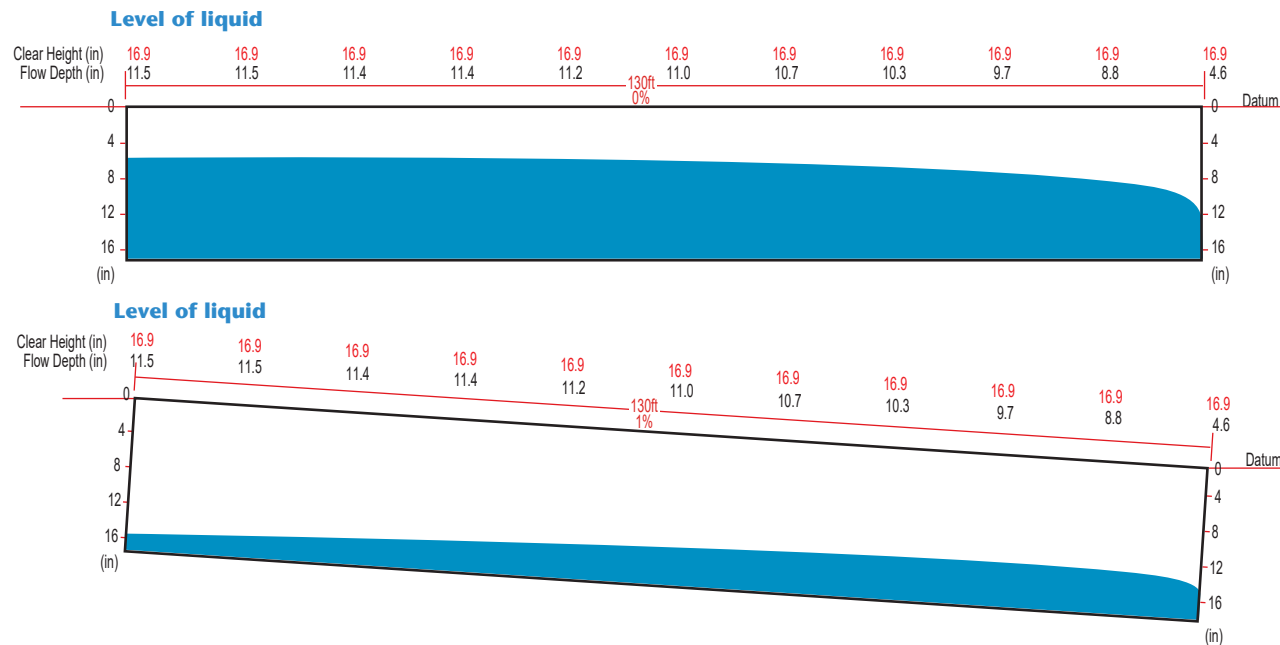

Size and type of outlet

In modeling hydraulic performance of trench drains, the assumption is that the outlet is not a restricting factor. Designers should ensure outlet, and subsequent pipe infrastructure, is not undersized and restricts outflow of the trench drain.

Limited

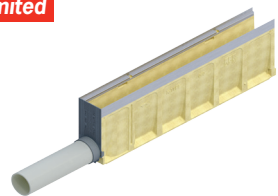

End outlet - pipe connected horizontally at the end of the trench. Minimizes excavation but offers lowest outlet capacity.

Good



Bottom outlet - pipe connected vertically out of the bottom of the trench. Offers improved outlet capacity due to gravity.

Better

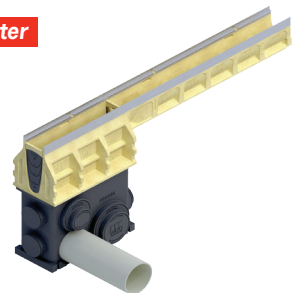

In-line catch basin - same width as trench, but deeper. Offers superior outlet capacity as large pipes can be connected and increased depth gives significant head of water pressure.

Best

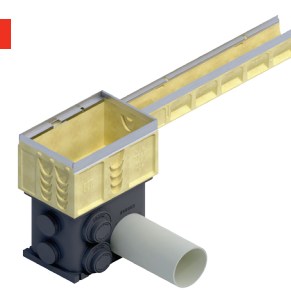

Catch basin - large basin wider and deeper than trench. Offers best outlet capacity as larger pipes can be used and increased depth gives significant head of water pressure.

SERVICE F



Ponding analysis - trench hydraulics

Temporary ponding is a short lived flood situation, which, in some circumstances, can be tolerated with an intentionally undersized trench drain. It allows a more economical system to be used that will work effectively under average weather conditions, but will be slightly under designed for heavy storms.

Ponding analysis should only be considered where buildings and property are not in close proximity to the drainage system to minimize risk of damage. It is an ideal option for the outer areas of large parking lots, distribution yards, etc. (Risk Analysis should be carried out). The ponding analysis map shows the size and duration of the flood.

In order to produce a ponding analysis, the following information is required:

- Full information required to run the Hydro printout. See page 143.
- Plan of site showing elevations
- Existence of any buildings

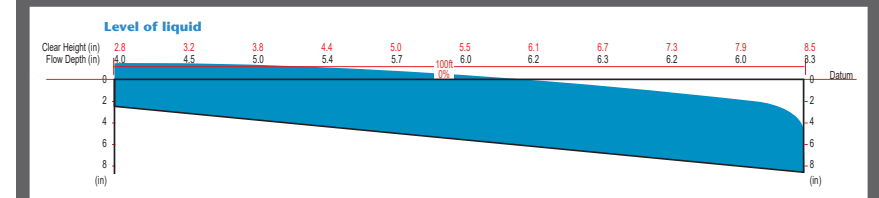

Flooded Hydro printout indicates that ponding will occur and either a Ponding Analysis should be done or channel metrics (width, depth, run length) re-evaluated.

Ponding analysis shows:

- Run-off scenario
- Trench drain length, size and type
- Design discharge
- Visual map of worst ponding scenario
- Width of temporary ponding
- Project notes

Position of outlet

A trench drain is ultimately connected to an underground pipe system. Outlet position can dramatically affect size and length of trench drain required.

End outlet - Water builds up along trench and may flood before reaching outlet. A larger/more costly trench drain and/or more outlets may be required.

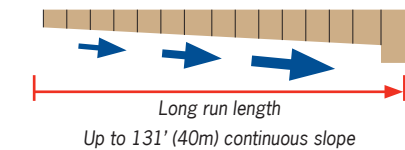

Central outlet - If zero ground slope, run lengths to outlet are shorter and less likely to exceed capacity and flood. Allows smaller, more economic trench drain and/or fewer outlets with associated pipework.

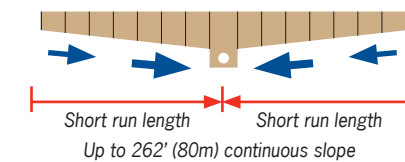

Double end outlet - Where zero ground slope, allows run lengths to outlet to be shorter and less likely to exceed capacity and flood. Allows smaller, more economic trench drain but more outlets and associated pipework.

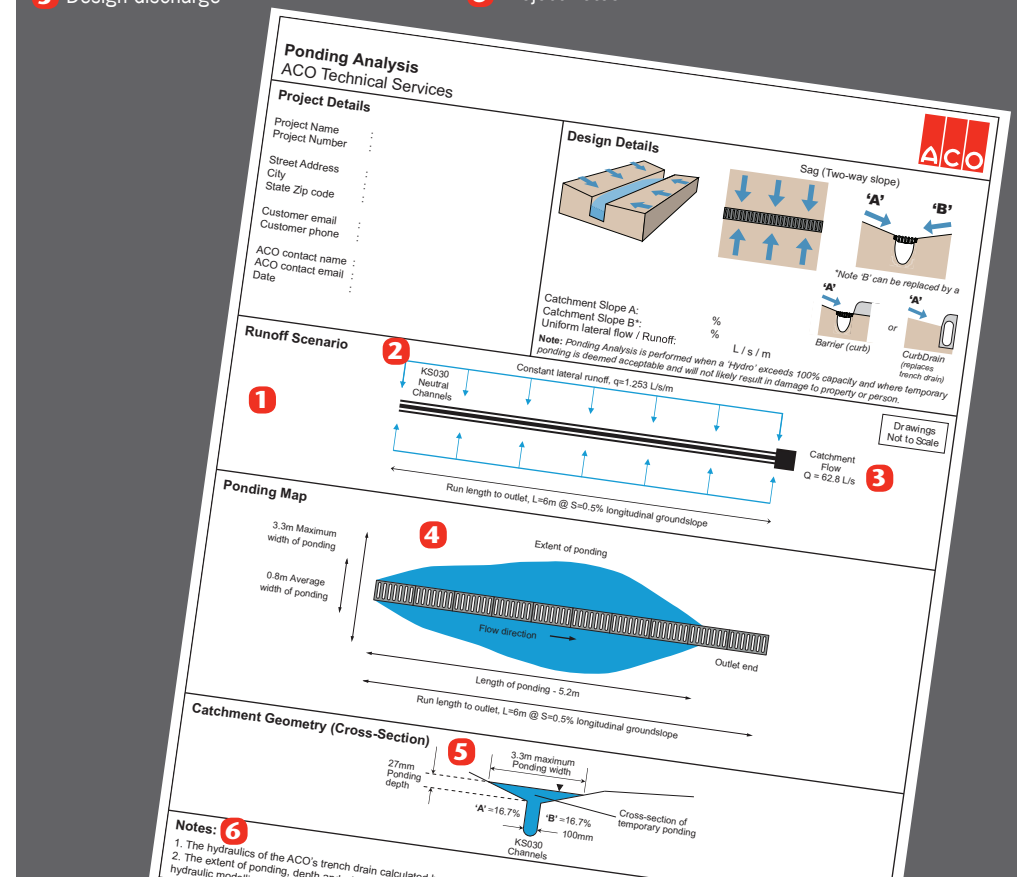
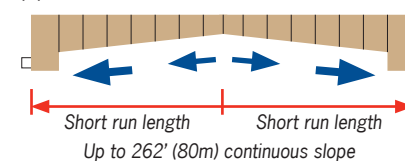



2. Hydraulics

Grate hydraulics

Usually the trench drain reaches hydraulic capacity before the grate. However, where there are concentrated flows running down steep slopes, the grate may not be capable of capturing all flow - even if the underlying trench is correctly sized.

Properly located trench runs put grates in the direct path of surface water runoff, exposing them to the following conditions:

- Flow rate of liquid from catchment area or point source(s). *See page 142.*
- Velocity and approach head (depth) of liquid determined by catchment roughness and slope.

A grate has a finite capacity to capture flow (surface water run-off) originating from catchment area - bypass occurs when the grate's hydraulic capacity is exceeded.

A grate's hydraulic performance is influenced by:

1. Grate characteristics

- Intake area
- Width of grate
- Design features e.g. direction of bars/slots, slip resistant features

2. Catchment characteristics

- Approach catchment slope (determines water velocity)
- Catchment roughness (determines flow direction, water velocity and head)
- One direction (barrier drain) or two or more directions (sag/valley drain)
- Type of liquid
- Debris

Designers should be aware of the trade-off between small inlets for heel safety and large inlets for optimum grate hydraulics.

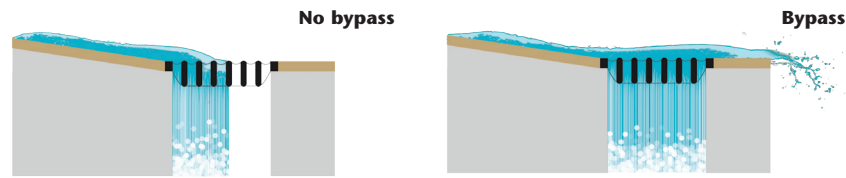

100% Capture
All liquid flowing through grate openings.

Less than 100% Capture
Not all liquid flows through grate openings - bypass occurs. Reasons:

- Not enough grate open area.
- Too much liquid.
- Too much slope perpendicular to grate.

The science of grate hydraulics is difficult to model in fluid mechanics. A grate's hydraulic performance can be greatly influenced by subtle changes to grate, and/or catchment characteristics described left.

When liquid moves over a grate, either/or a combination of two scenarios can occur:

- Weir scenario:** relevant where water depths are minimal and approach with speed.
- Drowned orifice:** relevant where there is an accumulation of water above grate.

Drains positioned in sag/valley locations give rise to higher flow rates due to pressure of substantial static head (liquid depth) being pushed through grate openings.

Longitudinal opening grate at capacity

When comparing grates of equal intake area and width, longitudinal opening grates offer maximum potential for flow evacuation leading to high water intake. For example:

- 4 bars to interrupt and slow down flow before weir is produced.
- Slots 1, 2, 3 are treated as drowned orifices.
- Slot 4 acts as a weir.

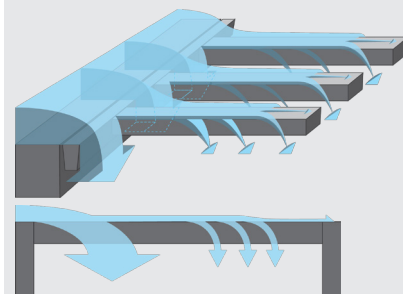
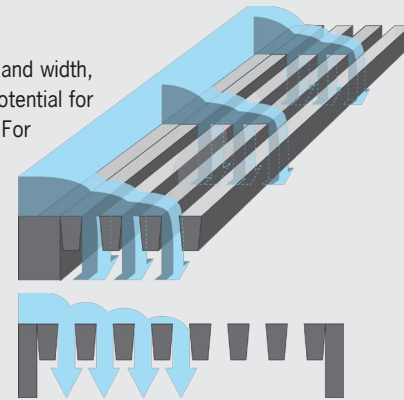

Transverse opening grate at capacity
When comparing grates of equal intake area and width, transverse grates offer moderate water intake. Bars bridge across both sides of trench giving little flow interruption, but some drowned orifice effect.

Slot opening grate at capacity
There is very little flow interruption before the weir is produced leading to low water intake. The minimal depth above the slot will have negligible drowned orifice effect.

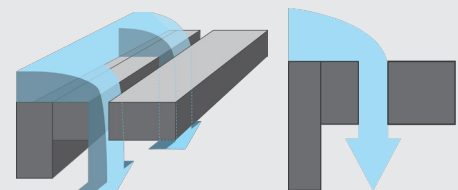

Grate intake experiments

Due to the complex nature of fluids in relation to grate inlet hydraulics, testing is the only way to accurately predict how a grate will intercept surface water run-off.

ACO has contracted leading universities for the purpose of research and testing, in the area of grate hydraulics. Three studies carried out in 2016, 2004 and 1998 show capture rates for a number of ACO grates recorded at various water flows discharging down a ramp at a set of longitudinal angles, and cross falls.

Based on project specific requirements, results from these empirical tests allow ACO to accurately recommend a grate for designers with specific catchment hydraulics.

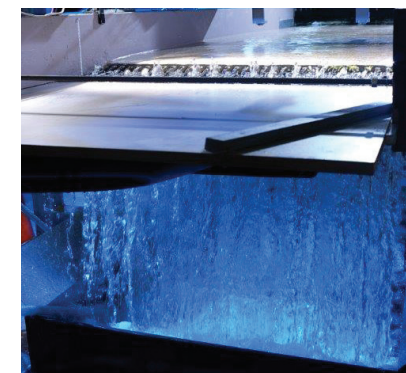

Measuring grate capture



Leaves and other debris can impact hydraulic performance and can be incorporated into ACO's software.

SERVICE G



Grate hydraulics - GIC service

ACO has independently measured, by experimentation, the hydraulic intake capacities of ACO grates. Tests were carried out under varying flow rates and catchment approach slopes. To determine the hydraulic utilization, each grate was tested until bypass occurred (point at which liquids would pass across grate).

ACO's Grating Intake Calculator (GIC) provides information on intake efficiency of chosen grate. If liquid intake is greater than grate's capacity, extent of bypass (or failure) will be calculated.

To generate results from the GIC program the following information is required:

- Length of trench run (feet or meters)
- Length and width of catchment area (feet or meters). *See page 142.*
- Position of trench in catchment area
- Surrounding pavement/surface type, e.g., concrete, asphalt, etc.
- Rainfall intensity (in/hr or mm/hr)
- Perpendicular approach slopes to trench (%)
- Preferred grate type

Results are provided either electronically and/or in printout format.

GIC printout shows:

- Catchment geometry and hydraulics
- Total intake area per foot of trench run
- Recommended grate information
- Hydraulic utilization of grate (100% means all grate intake capacity is used)
- Additional notes relating to grate performance

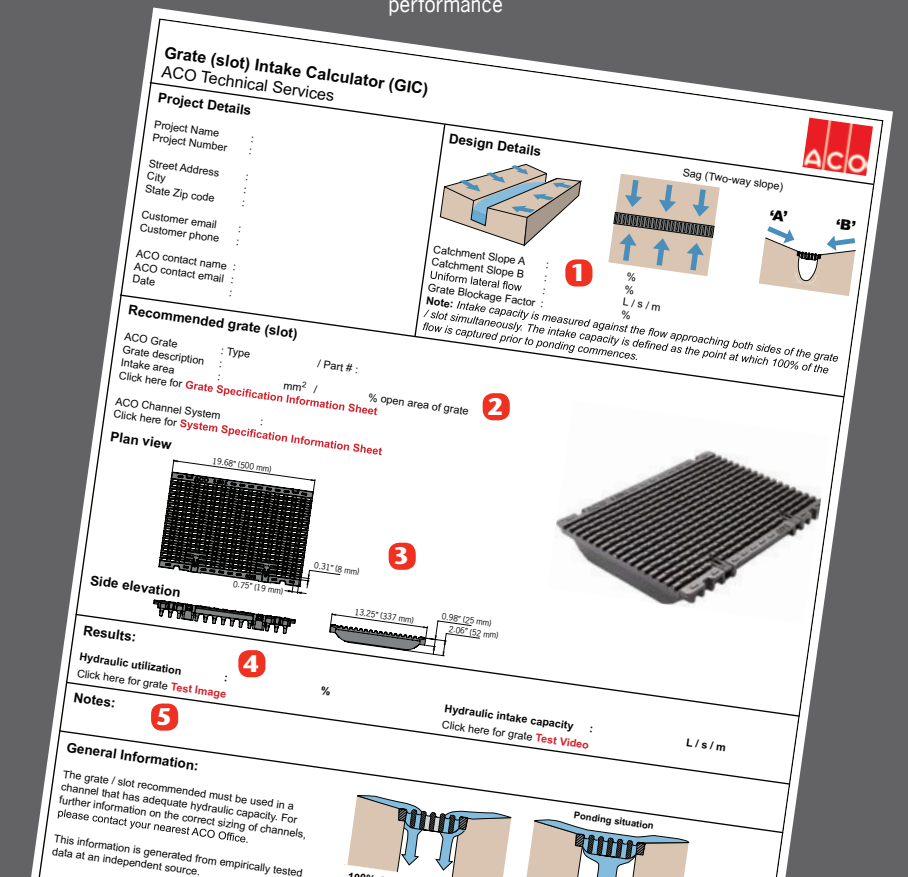

3. Trench layout

SERVICE H



CAD layout & part scheduling

Run layout service and part scheduling

ACO Scheduler

ACO has written a proprietary software program, Scheduler, that shows trench drain runs in profile and plan views. The program automatically prints out each run showing positions of accessories, outlets, junctions, etc. It automatically calculates a Bill of Materials for each run and totals multiple runs to ensure the correct amount of parts and pieces are ordered. Scheduler printouts are particularly useful for installers.

Results provided are:

- Sectioned profile of trench runs
- Plan view of trench runs
- Parts schedule fully itemizing parts and pieces

Scheduler printouts provide:

- Profile and plan view of each trench run
- Trench run direction change - e.g. 90° corner or junction
- Positions and type of outlets
- Detailed Bill of Materials to ensure all parts are correctly ordered



MATERIAL LIST		
KS100		
PART #	DESCRIPTION	QTY
74409	9 SLOPING CHANNEL	1
74410	10 SLOPING CHANNEL	1
74411	11 SLOPING CHANNEL	1
74412	12 SLOPING CHANNEL	2
74413	13 SLOPING CHANNEL	2
74414	14 SLOPING CHANNEL	3
74415	15 SLOPING CHANNEL	4
74416	16 SLOPING CHANNEL	6
74417	17 SLOPING CHANNEL	7
74418	18 SLOPING CHANNEL	7
74419	19 SLOPING CHANNEL	7
74420	20 SLOPING CHANNEL	8
74446	0203 1/2m NEUTRAL CHANNEL	8
74421	21 SLOPING CHANNEL	1
74422	22 SLOPING CHANNEL	4
74423	23 SLOPING CHANNEL	4
74424	24 SLOPING CHANNEL	4
74425	25 SLOPING CHANNEL	4
74426	26 SLOPING CHANNEL	4
74427	27 SLOPING CHANNEL	4
74428	28 SLOPING CHANNEL	4
74429	29 SLOPING CHANNEL	4
74430	30 SLOPING CHANNEL	4
74431	31 SLOPING CHANNEL	4
74432	32 SLOPING CHANNEL	4
74433	33 SLOPING CHANNEL	2
74434	34 SLOPING CHANNEL	2
74435	35 SLOPING CHANNEL	2
74436	36 SLOPING CHANNEL	2
74437	37 SLOPING CHANNEL	2
74438	38 SLOPING CHANNEL	2
74439	39 SLOPING CHANNEL	2
74440	40 SLOPING CHANNEL	2
TOTAL 1m CHANNELS		118
TOTAL 1/2m CHANNELS		1
98822	UNIVERSAL CLOSING INLET/OUTLET CAP	1
02899	QUICKLOK LOCKING BAR	8
08971	4470 ADA SS GRATE 30.37" (1.0m)	237
98891	4480Q ADA SS GRATE 19.69" (0.5m)	118
95140	4" OVAL TO 6" ROUND OUTLET ADAPTER	1
		4

CAD design services

For more complex projects ACO can provide a custom trench drain layout using Auto-CAD to illustrate required positions and layouts of trench runs.



In order to produce a plan layout, the following information is required:

- Plan of site showing elevations
- Existence of any depth restrictions
- Position and type of any plumbing fixtures/outlets
- Position of any permanent structures
- Liquid flow pattern and type of traffic (including traffic flow)

Results provided are:

- Plan layouts (CAD) showing the trench drain positions relative to site structures

CAD printout provides:

- Plan view of trench run layout with inverts
- Liquid flow directions
- Position and type of outlet
- Trench and grate type

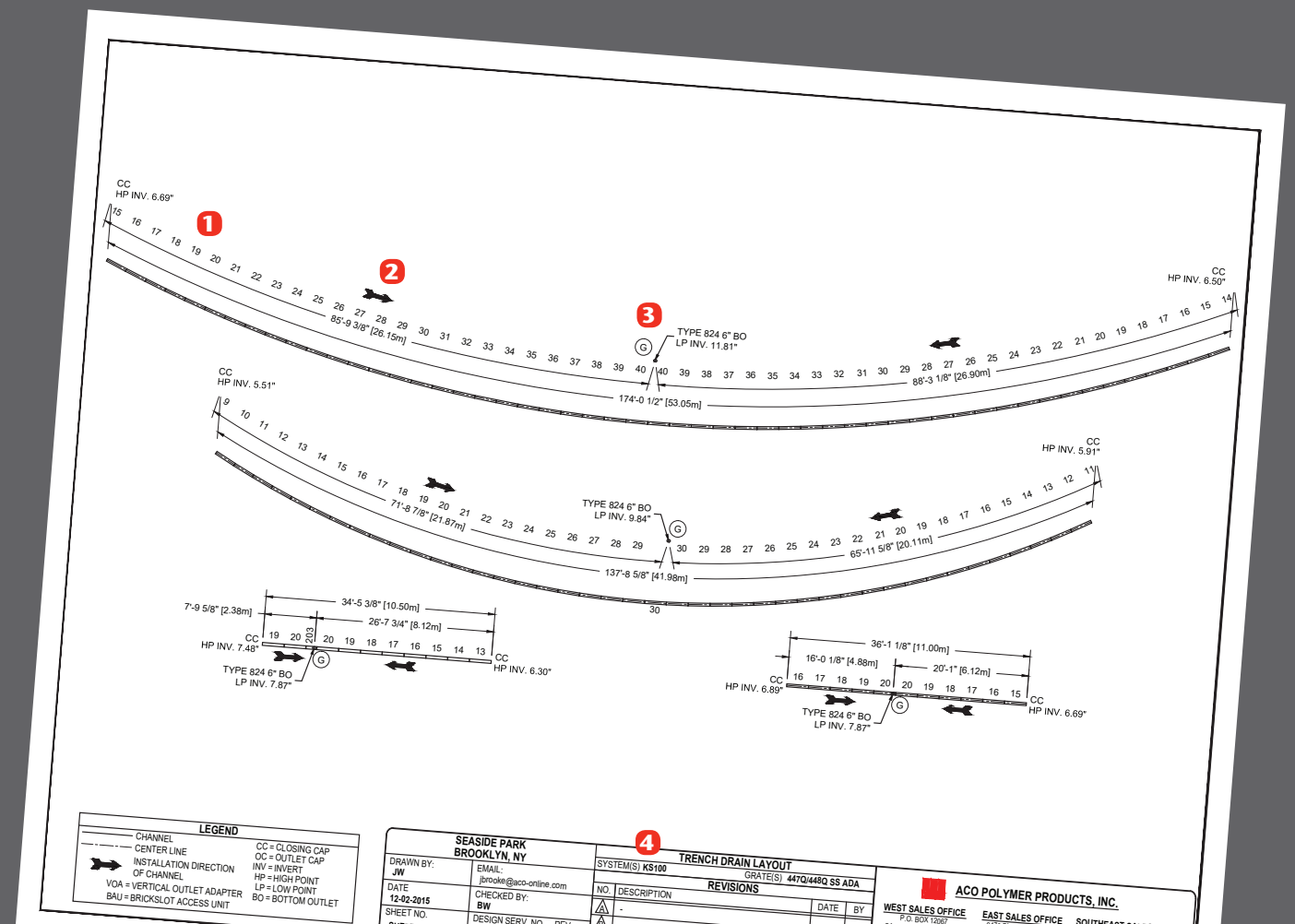
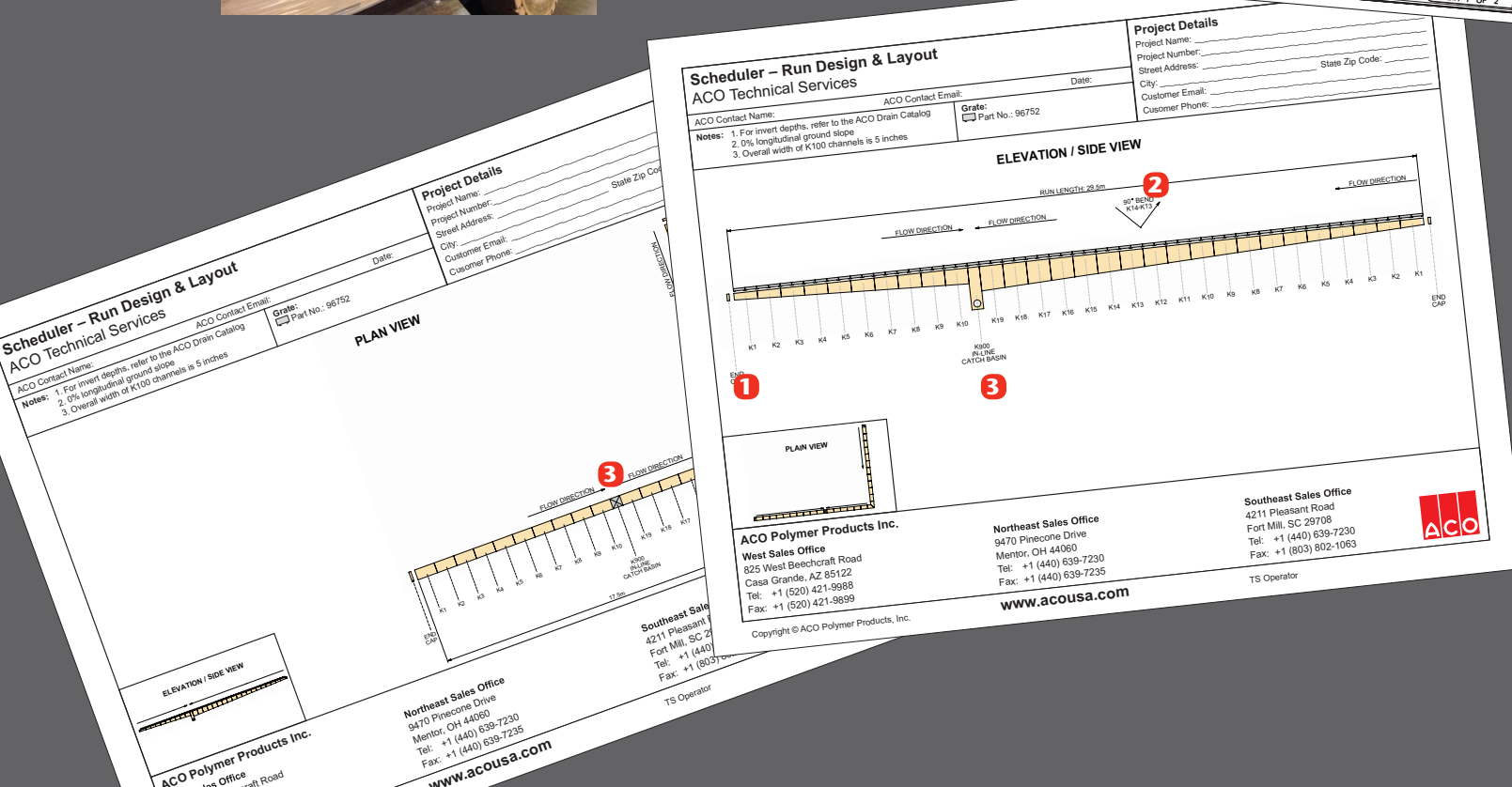



ACO has a qualified site support technician available for installation training and assistance.

A fabrication service can assist with creating difficult corners, tees, shortened channels, etc. to make installation quicker and easier.

A Site Installation Guide is available, in addition to installation section drawings.

1	Installation	152
	- Overview of key steps required	
2	Site work	154
	- Specific areas to consider	
3	Layout options	155
	- Connection options for complex layouts	
4	Installation sections	156
	- Overview of different pavements and loadings	



Installation guidelines



4. Installation support

Installation

Channel units are installed in a continuous trench, and are encased with concrete.

Full installation instructions are available in the Site Installation Manual. Contact ACO or visit www.ACODrain.us or view ACO Installation videos on www.youtube.com/user/acoamerica

1. Excavation

Excavate trench to accommodate trench drain system. Excavation should be around center line of trench.

Excavation must be sufficient enough to accommodate each of the following:

- Channel/catch basin width and depth dimensions.
- Concrete surround dimensions - 4" - 12". Specific loading and ground conditions will increase the excavation size. *See page 156 for further guidelines.*
- For sloped systems, excavate base to roughly follow fall of trench drain run.



2. Outlet installation

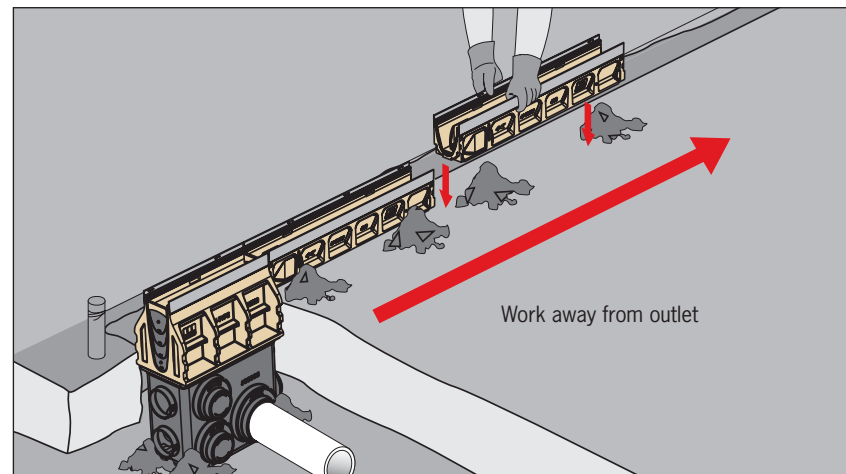

All installations should start from outlet point.

- Determine type of outlet and position
- Install outlet channel/catch basin and set haunch
- Install channels starting at, and working away from, outlet - from deepest (highest channel number) to shallowest

3. Trench drain installation

Channel units need to be supported at correct height and held securely in place to avoid movement during concrete pour. There are a number of options available:

Patty supports

Care should be taken that concrete is not trapped in joint between channels.

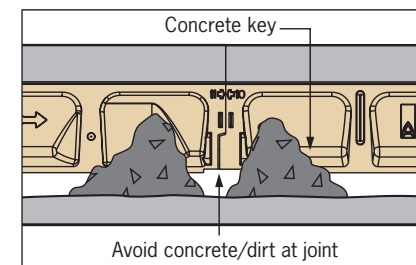

Installation device

A clamping system that fits around the profiled end. Rebar is used to achieve correct height. One device per joint is required. 100, 200 & 300mm wide versions available.

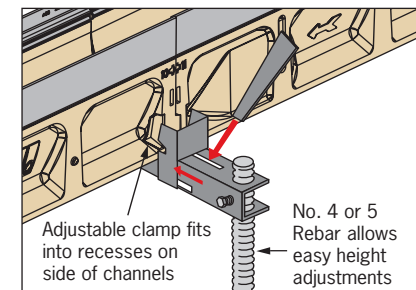

FG200 has installation devices attached to frames for attaching No. 4 or 5 rebar.

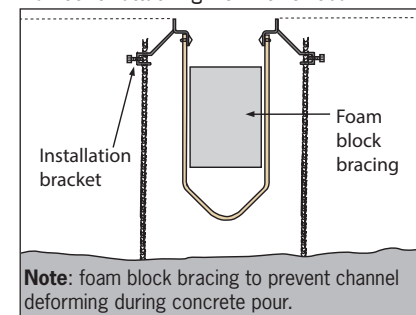

Note: foam block bracing to prevent channel deforming during concrete pour.

Hanging method

Channels can also be hung from grate locking. Useful in retrofit where existing slab is used to support channels.

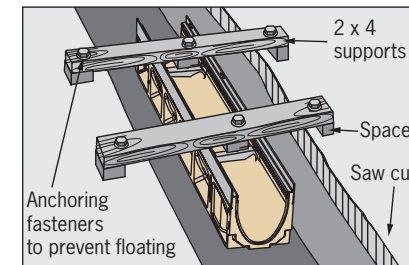

4. Channel bracing

To prevent channel walls and joints being distorted by pressure of concrete, grates (or plywood cut to a snug fit) should be installed in channel prior to concrete pour.

Shims or washers placed along each side allow easy removal of the grates.

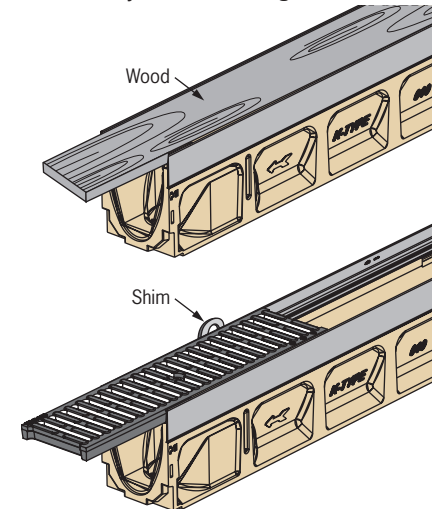

5. Concrete pour

Concrete should have compressive strength of minimum 4,000 psi.

Grates should be suitably wrapped to protect from concrete splash.

Concrete should be poured evenly (both sides of channel) and carefully to avoid dislodging channels. A wand-type vibrator should be used to ensure concrete distributes evenly underneath and around channels.

6. Pavement finishing

Top of adjacent pavement must be above grate level by approximately 1/8" (3mm).

Brick pavers should be set approx. 1/8" (3mm) above trench edge. First brick course should be set on mortar/concrete.

Care should be taken with asphalt rolling machines to avoid damage to trench edge.

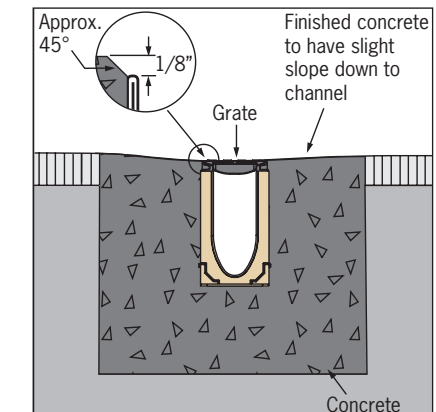

7. Completing installation

- Remove grates and remove protective wrapping.
- Remove debris from trench drain and make sure outlet pipes are clear.
- Install trash buckets in catch basins, if required.
- Flush trench run to check for pipe work blockages; unblock if necessary.
- Empty trash buckets and clean out pipe connections, if necessary. Re-install trash buckets.
- Re-install grates in proper position ensuring they are securely locked down.

The trench drain is now ready for use.

Maintenance

Regular inspections of the trench drain are recommended. Frequency will depend on local conditions and environment, but should be done at least annually.

Inspections should cover:

- Grates and locking devices
- Catch basins and trash buckets
- Concrete surround and adjacent paving

All items should be inspected for damage, blockage or movement. Compare with site drawings if necessary.

Maintenance guidelines:

1. Remove grates
2. Remove debris from channel
3. Flush channels with water or high pressure washer (do not use boiling water or aggressive cleaning agents)
4. Repair damaged surfaces where necessary with an appropriate ACO repair kit. *See page 154.*
5. Renew joint seals as required
6. Empty trash buckets and clean out pipe connections
7. Re-install trash bucket
8. Re-install grates, ensuring they are locked back in place





4. Installation support

Site work

ACO provides separate installation details for each product with comprehensive on-site advice, when appropriate.

Ground conditions

Specific ground conditions or contaminated ground may call for a deeper/wider concrete surround or larger haunch than minimum recommendations.

If in doubt, seek engineering advice.

Thermal movement

Longitudinal expansion joints, which for some slabs may be doweled horizontally and de-bonded, will isolate the trench and concrete haunch from thermal movement of large concrete slabs.

Transverse joints in the concrete slab should be positioned to coincide with channel-to-channel joints. Alternatively the channel may be cut to align with the slab joint and resealed with a suitable flexible sealant.

Engineering advice should be sought for specifying expansion joints.

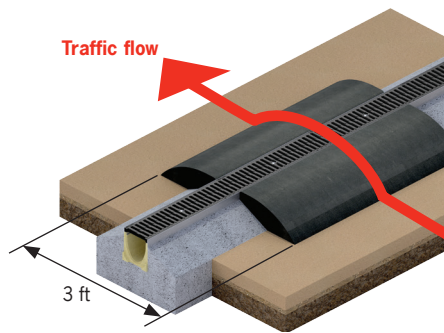

Temporary installation

During site work, and after trench run is laid, the trench top can be vulnerable to damage. Site traffic should be routed away from the trench. If temporary crossings are required, a base course of minimum width 3 feet should be installed either side of the trench for protection. Loose boards or plates are inadequate.

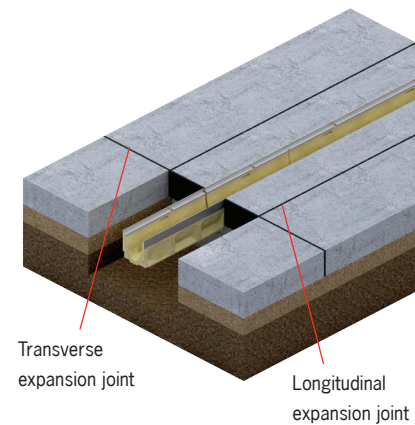

Site work accessories

Seal and patch materials

	Part No.	Weight lbs
ACO Seal flexible joint sealant - 10oz	91120	1.0
ACO Bond - polymer concrete repair kit - 1 gallon	06519	11.0
ACO Bond - polymer concrete repair kit - 5 gallons	06516	55.0
ACO Fiberglass repair kit - 1 gallon	08203	11.0



Joint sealing

All channel-to-channel and channel-to-fitting joints should be sealed with appropriate sealant.

ACO channels are supplied with an 'SF Sealant Groove' as standard. This provides a groove that can be filled with an appropriate flexible sealant to create a watertight joint. This is particularly important with elevated slabs and where liquids may contain chemicals or oils.

Sealant should be resistant to the same chemicals as the trench material and be flexible to allow for any slab movement from temperature changes. Surfaces should be correctly prepared prior to applying sealant to ensure good adhesion.

Contact ACO Technical Department, or go to www.ACODrain.us for Technical Bulletin.



Sealant applied with caulk gun

Connection options

Male-female connection

Interconnecting end details allow easy and effective joining of channels. It also helps with height and sideways alignment between channels. An SF groove provides positive placement for appropriate sealant.

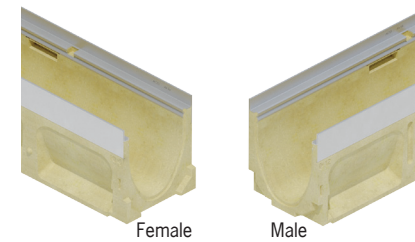

Female-female connection

Creation of a direction change and high point, requires an outlet at start and end of run. To create, remove female end details and butt channels together, hold in place with ACO Bond.

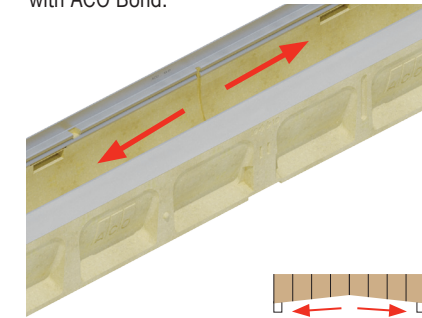

Male-male connection

Creation of a low point, usually with bottom outlet where a catch basin is not required. To create, butt male ends together and fill gaps with ACO Bond.

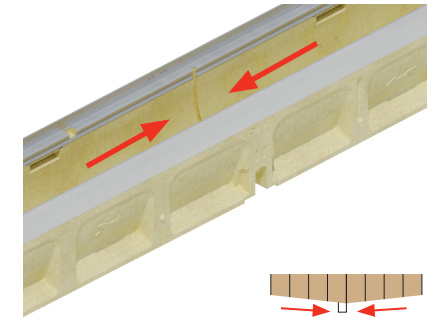

Arrows depict direction of slope and flow

Corner

Corners can be created by butting up as shown below or both channels mitered at 45°.

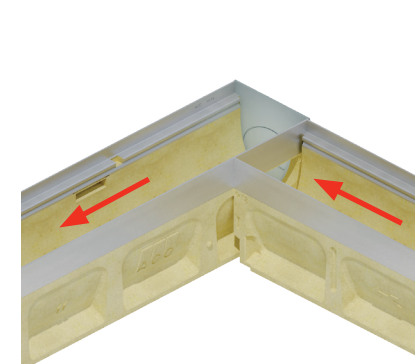

Tee junction

Junction details on sides of constant depth channels allow on-site creation of tees without fabrications. Edge rails and grate seats remain intact for structural integrity.

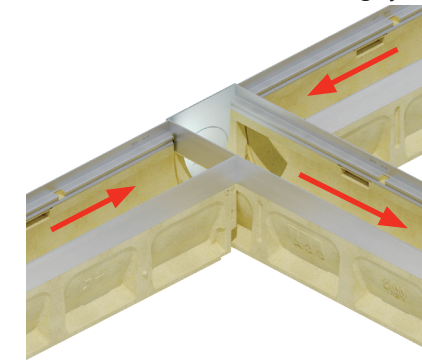

X - cross

Junction details on sides of constant depth channels allow on-site creation of x - cross without fabrications. Edge rails and grate seats remain intact for structural integrity.

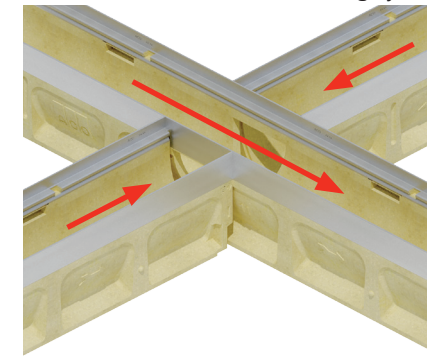

Catch basins

The catch basin is typically the low point and has female connections at each side for easy connection to male (deeper) channel end.

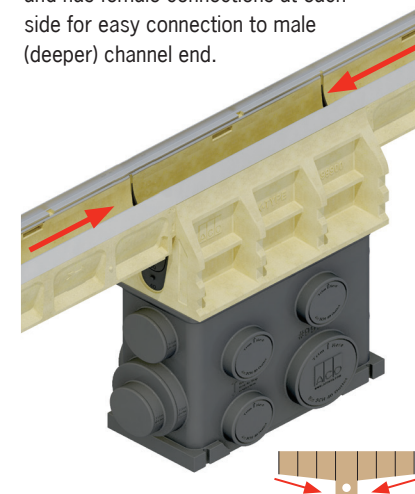

Blanking end plates

For 100mm in-line basins a blanking end plate is supplied to prevent concrete ingress during concrete pour. It also provides an aesthetic end finish.



Blanking end plates

For 200 and 300mm catch basins, a kit is available to close one end and fill gaps between channel and catch basin.

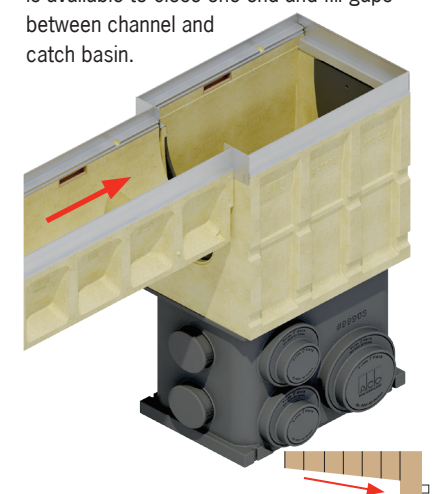



4. Installation support

Installation sections

An installed ACO Drain System should incorporate the following:

- Correct grate type
- Correct channel type and size
- Minimum grade 4,000 psi compressive strength cement concrete surround

It is recommended that the cement concrete surround be durable and conform to minimum strength requirements, as shown in the illustrations. Poor site conditions and low load bearing pavements will require an increase in these dimensions to meet both vertical and lateral loads.

These illustrations are a guide for average ground conditions only. Electronic installation drawings are available at www.ACODrain.us.

It is the customer's responsibility to ensure that encasement size and detail is suitable for the specific application.

These illustrations are typical only.

If in doubt, seek engineering advice.

**4 in. (100mm) Channels
BLOCK PAVERS - EN 1433 Class B**

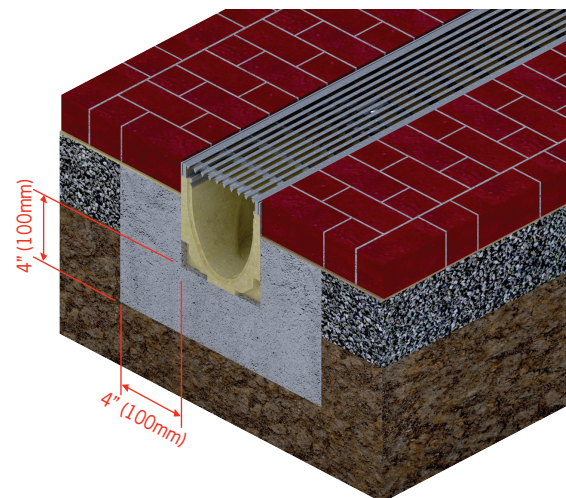

Note:
1. Grate should be 1/8" (3mm) below pavement surface.

**8 in. (200mm) Channels
BLOCK PAVERS - EN 1433 Class B**

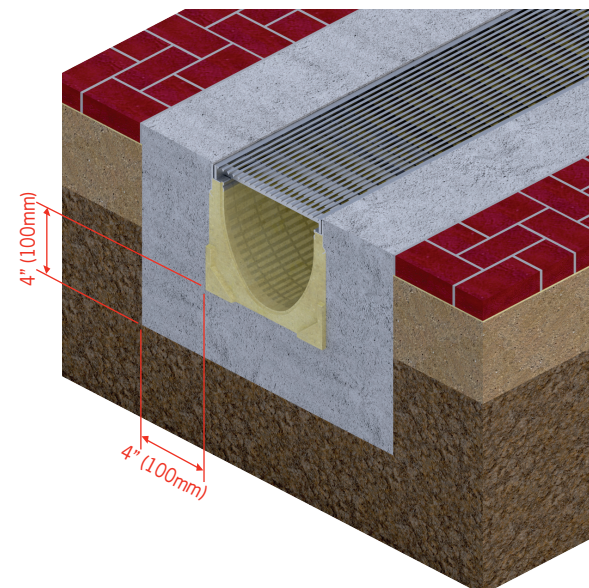

Note:
1. Grate should be 1/8" (3mm) below pavement surface.
2. Installation brackets on FG200 require a minimum 10" (250mm) surround.

**8 in. (200mm) Channels
ASPHALT - EN 1433 Class C**

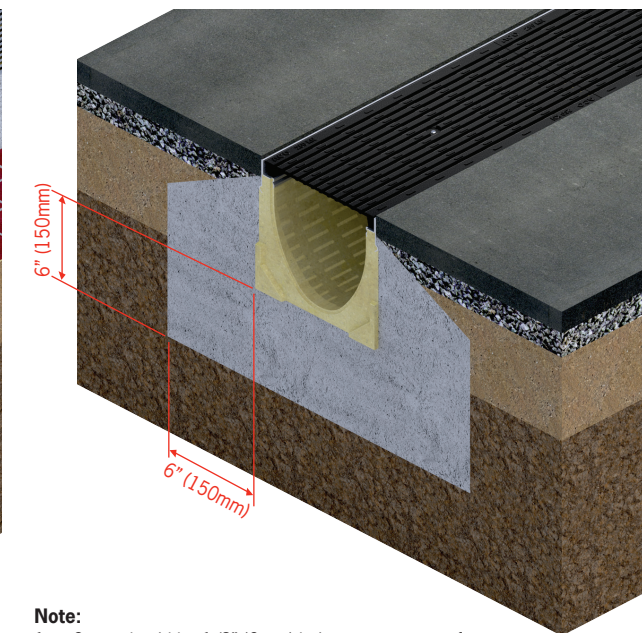

Note:
1. Grate should be 1/8" (3mm) below pavement surface.
2. Installation brackets on FG200 require a minimum 10" (250mm) surround.
3. Care should be taken with asphalt rolling machines to avoid damage to channel edge and/or grate.

**4 in. (100mm) Channels
ASPHALT - EN 1433 Class C**

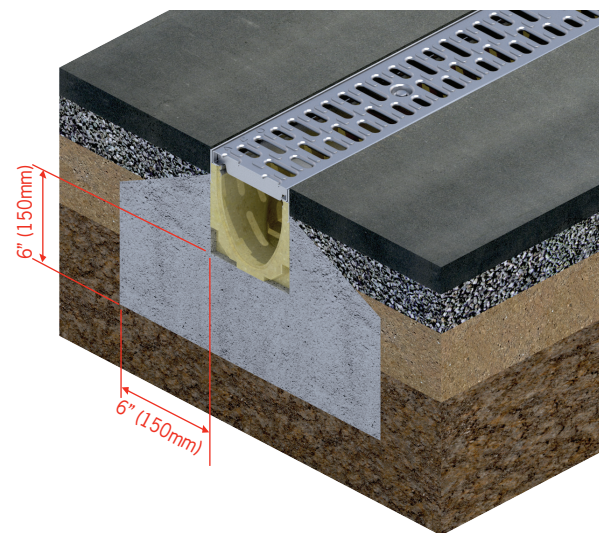

Note:
1. Grate should be 1/8" (3mm) below pavement surface.
2. Care should be taken with asphalt rolling machines to avoid damage to channel edge and/or grate.

**4 in. (100mm) Channels
CONCRETE - EN 1433 Class E/F**

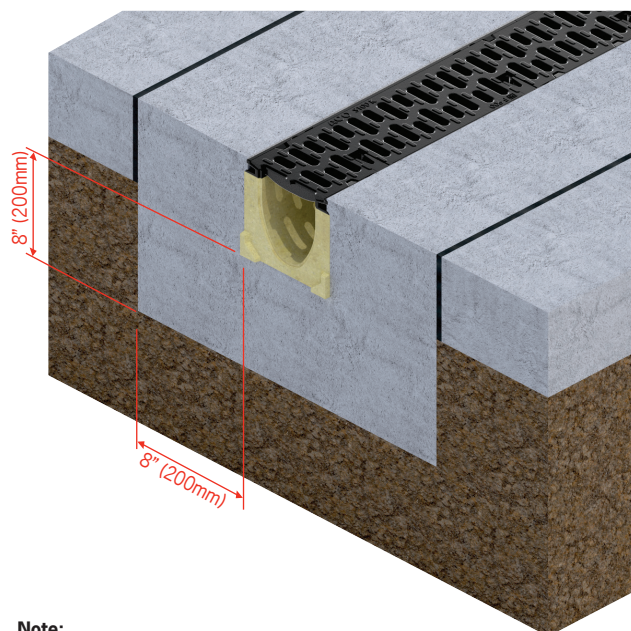

Note:
1. Grate should be 1/8" (3mm) below pavement surface.

**8 in. (200mm) Channels
ASPHALT - EN 1433 Class C**

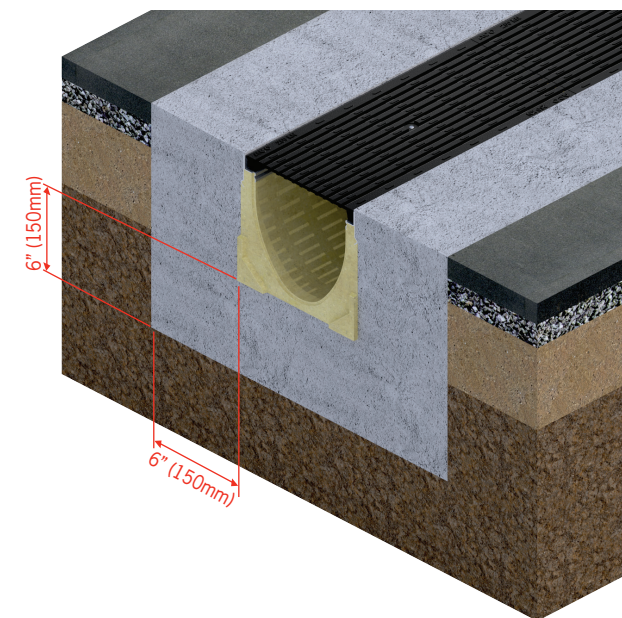

Note:
1. Grate should be 1/8" (3mm) below pavement surface.
2. Installation brackets on FG200 require a minimum 10" (250mm) surround.

**8 in. (200mm) Channels
CONCRETE - EN 1433 Class E/F**

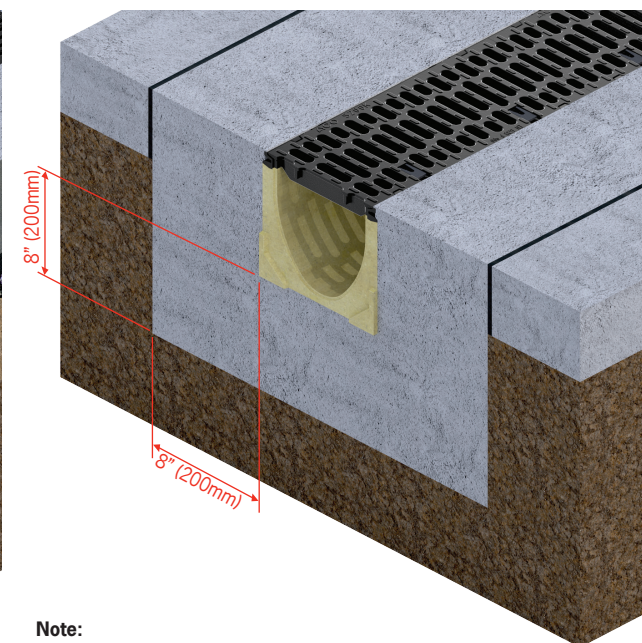

Note:
1. Grate should be 1/8" (3mm) below pavement surface.
2. Installation brackets on FG200 require a minimum 10" (250mm) surround.





4. Installation support

Installation sections

12 in. (300mm) Channels BLOCK PAVERS - EN 1433 Class B

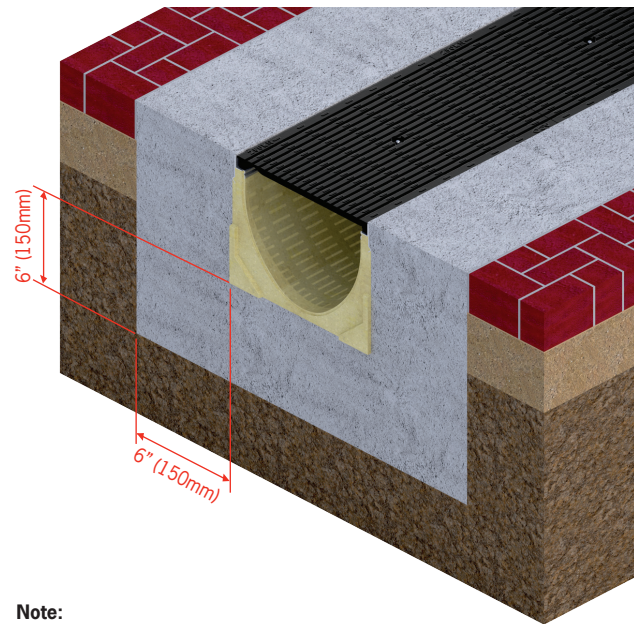

Note:
1. Grate should be 1/8" (3mm) below pavement surface.

12 in. (300mm) Channels ASPHALT - EN 1433 Class C

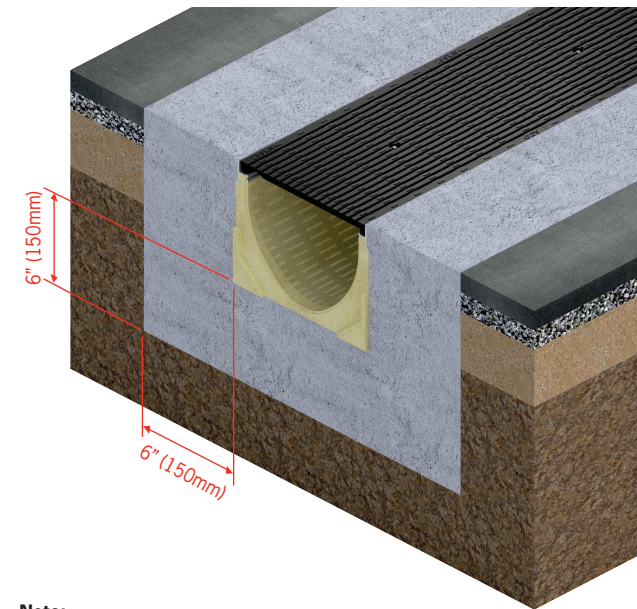

Note:
1. Grate should be 1/8" (3mm) below pavement surface.

12 in. (300mm) Channels CONCRETE - EN 1433 Class E

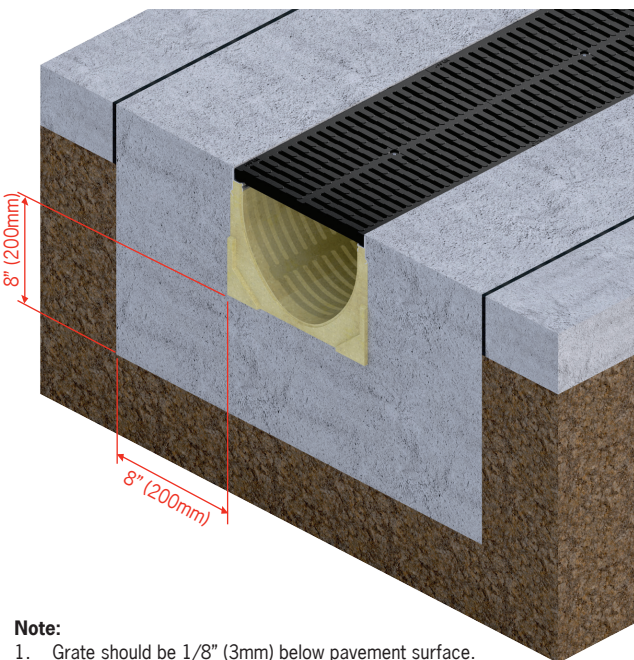

Note:
1. Grate should be 1/8" (3mm) below pavement surface.

12 in. (300mm) Channels CONCRETE - EN 1433 Class F

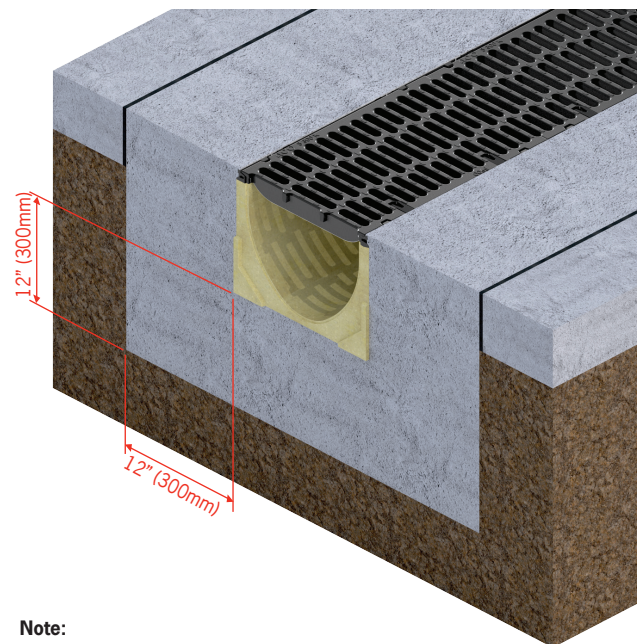

Note:
1. Grate should be 1/8" (3mm) below pavement surface.

Glossary

AASHTO - American Association of State Highway & Transportation Officials.

ADA - Americans with Disability Act. *See page 140.*

Anti-shunt lugs - interlocking details on grate and edge rail prevent longitudinal movement - *see Product pages.*

Anti-slip grates - slip resistance of grates has been tested using ASTM E303. *See page 141.*

AS 3996 - Australian Access Covers & Grates standard detailing Bicycle Safe grate specifications. *See page 140.*

ASME - American Society of Mechanical Engineers.

ASTM - American Society for Testing and Materials.

Bell end - flared end of pipe to accept a certain pipe size inside - similar to coupler.

Bicycle safe - grate with slots that reduce 'tram-lining' of tires. *See page 140.*

Bolt sizes - diameter - pitch per inch x length (from seat of head to base).

Catchment area - paved area that will collect liquids. *See page 142.*

Cast-in-place - trench that is produced during concrete pour by removable forms.

Catch basin - large basin to collect liquid into underground pipe work.

CFS - cubic foot per second - measure of flow.

Channel - individual modular unit.

Chemical resistance - ability to withstand specified chemicals.

Corrosion resistance - ability to withstand weathering.

Cut-outs - shaped plastic inserts cast in ends of polymer concrete catch basins to enable easy removal of material for channel connection.

DrainLok™ - ACO's patented boltless locking system for KlassikDrain and SlabDrain HK Series. *See page 15 & 98.*

Drill-outs - shaped recesses cast in polymer concrete unit to enable easy removal of material for pipe/channel connection.

Ductile iron - pig iron with magnesium added to provide added durability and strength. Often referred to as spheroidal graphite (SG) iron.

Edge protection - metal edge rail to prevent impact or general damage to trench body - *see page 136.*

EN 1433 - international load standard supersedes DIN 19580. *See page 132.*

Foul air trap - shaped pipe section to prevent odors traveling up from underground waste water system.

Free area - area for water flow. Determined by clear opening (width) and invert depth. *See page 9.*

Freestyle - new semi-custom grates. *See page 20.*

FRP - fiber reinforced plastic.

Galvanized steel - black steel with protective galvanized coating.

GIC - ACO's proprietary software program to calculate grate intake hydraulics. *See page 147.*

GPM - Gallons per Minute - measure of flow.

Grade - angle of pavement slope. *See page 142.*

Gray iron - pig iron melted in a furnace and poured into molds.

Grate hydraulics - performance of liquid entering grate openings. *See page 146.*

Ground slope - percentage of slope along length of trench. *See page 142.*

Heel resistant - ASME standard stating maximum grate slot size of 0.31" (8mm), deemed safe for heeled shoes. *See page 140.*

Heel safety - ACO stipulated criteria of maximum grate slot size of 0.25" (6.5mm), deemed safe for stiletto shoes. *See page 140.*

Hydro - ACO's proprietary software program to accurately calculate trench hydraulics. *See page 143.*

Hydrological cycle - cycle of water from oceans to rainfall and back to the ocean.

In-line catch basin - similar width basin connected to trench which acts as exit point to underground pipe work.

Invert depth - depth from top of grate to inside base of channel. *See page 9.*

kN - kilonewton - measurement of force, 1kN = 224.8lbs (102kg) of force.

LEED (Leadership in Energy and Environmental Design) - promotes whole building approach to sustainability. *See page 138.*

Lateral intake - liquid entering the trench from surrounding paved area.

Male - has protruding details to interconnect with a female piece to enable a good fit.

Low Impact Design (LID) - collection, treatment and reuse of rainwater. *See page 138.*

Manning's equation - (steady uniform flow) equation for calculating flow in pipes or culverts. Does not allow for lateral intake of liquids.

Manning's roughness coefficient - measure of roughness of a material's surface. *See page 137.*

Non-uniform flow - irregular flow velocity in trench due to continuous lateral intake. *See page 142.*

Open swale - cast-in-place dish in paved area with little depth and no grate.

Overall depth - depth from top of grate to underside of channel.

Pavement - paved area surrounding trench.

Plain end - section of pipe, will require coupler connection.

Polymer concrete - mineral aggregates mixed with a resin binding agent. *See page 136.*

Ponding Analysis - calculated temporary flooding deemed acceptable for certain projects. *See page 145.*

PowerLok™ - ACO's patented boltless locking system consisting of a sliding clip that locks onto the edge rail. *See page 64.*

psi - pounds per square inch.

QuickLok™ - ACO's patented boltless locking system consisting of shaped stud and spring clip. *See page 16.*

Scheduler - ACO's proprietary software program to illustrate/profile trench layouts. *See page 148.*

SF groove - void at channel joint to allow application of a sealant. *See page 97.*

Slip resistance - measure of coefficient of friction of grate surface. *See page 140.*

Socket - recess to accept a pipe size inside - similar to a coupler, see also 'Bell end'.

Spigot - section of pipe, will require a coupler connection, see also 'Plain end'.

Stainless steel - mild steel with a minimum of 11% chromium added to provide enhanced corrosion resistance. There are a wide number of stainless steels available, each with differing properties. ACO grates are Grade 304 austenitic stainless steel.

Steady uniform flow - constant flow velocity in trench/pipe. See Manning's Equation.

Sustainable Drainage (SUDS/WSUDS) - low impact design (LID) leads to collection, treatment and reuse of rainwater. *See page 138.*

Trench - complete drain system in paved area.

USGBC (U.S. Green Building Council) - promotes environmentally responsible, profitable and healthy construction. *See page 7.*

Visualizer - online grate selection aid. *See page 18/141.*



Other ACO products

Surface water drainage

ACO Sport

Surface drainage and building accessories for track & field.

ACO Infrastructure

Surface drainage products engineered for highways, urban roads and bridges.

Aquaduct

Custom design and manufacture of fiberglass trench drain systems.

ACO Duct

Linear ducting system with removable solid covers.

ACO Environment

Oil water separator and spill containment systems.

ACO Wildlife

Tunnel and fence system to guide amphibians and other small creatures safely across roads.

ACO StormBrixx

A unique and patented plastic geocellular storm water management system.

ACO Self

Simple drainage and building component for use around the home, garden and office.

Building drainage

ACO QuARTz

Bathroom drainage.

ACO BuildLine

Drainage products for thresholds, balconies, green roofs and building façades.

ACO Stainless

Stainless steel trench drains.

ACO Floor Drain

Stainless steel floor drains.

ACO Pipe

Stainless steel push-fit pipe system.

ACO Polymer Products, Inc.

West Sales Office

825 W. Beechcraft St.
Casa Grande, AZ 85122
Tel: (520) 421-9988
Toll Free: (888) 490-9552
Fax: (520) 421-9899

Northeast Sales Office

9470 Pinecone Drive
Mentor, OH 44060
Tel: (440) 639-7230
Toll free: (800) 543-4764
Fax: (440) 639-7235

Southeast Sales Office

4211 Pleasant Road
Fort Mill, SC 29708
Toll free: (800) 543-4764
Fax: (803) 802-1063

Follow us on



Electronic Contact:

www.acodrain.us
info@acousa.com

© August 2016 ACO Polymer Products, Inc.

All reasonable care has been taken in compiling the information in this document. All recommendations and suggestions on the use of ACO products are made without guarantee since the conditions of use are beyond the control of the Company. It is the customer's responsibility to ensure that each product is fit for its intended purpose and that the actual conditions of use are suitable. ACO Polymer Products, Inc. reserves the right to change products and specifications without notice.

Re-order Part # DL099

